

GAGEMAKER

Product Information



DETERCO, INC.
Quality Products and Services

www.gagemaker.com

We would like to thank you for taking the time to view our catalog. It contains many new features and products. We hope this catalog will provide you with the necessary information to familiarize yourself with all of our products, as well as, make it easier to find the best product for you.

This catalog is an example of Gagemaker's continued commitment to adapt and improve not only our product, but the industry as a whole. Gagemaker's dynamic innovation and unparalleled products will continue to push the boundaries of the thread inspection industry.

We appreciate your business and hope you continue your patronage with us for all of your gauging and calibration needs.

Thank you,

The Gagemaker Team

***Copyright © 2020 Gagemaker, LP. All Rights Reserved.
MRP, JSS, and Gagemaker are registered trademarks of Gagemaker, LP. All Rights Reserved.***

Gagemaker, LP









P.O. Box 87709, Houston, Texas 77287-7709

712 East Southmore Ave., Pasadena, Texas 77502

Phone: 713-472-7360 • Fax: 713-472-7241

Email: gagemaker@gagemaker.com or sales@gagemaker.com

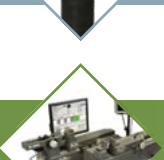
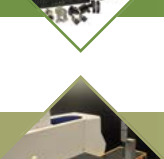
Web: www.gagemaker.com

	<i>Straight Thread Inspection</i>	4
	<i>Tubing & Casing Inspection</i>	20
	<i>Rotary Shouldered Connection Inspection</i>	36
	<i>Premium Connection Inspection</i>	54
	<i>Mud Motor Power Section</i>	68
	<i>Custom Gages</i>	78
	<i>Measurement & Calibration</i>	82
	<i>Calibration, Service, and Repair</i>	94
	<i>Gagemaker Products</i>	102



Straight Thread Inspection

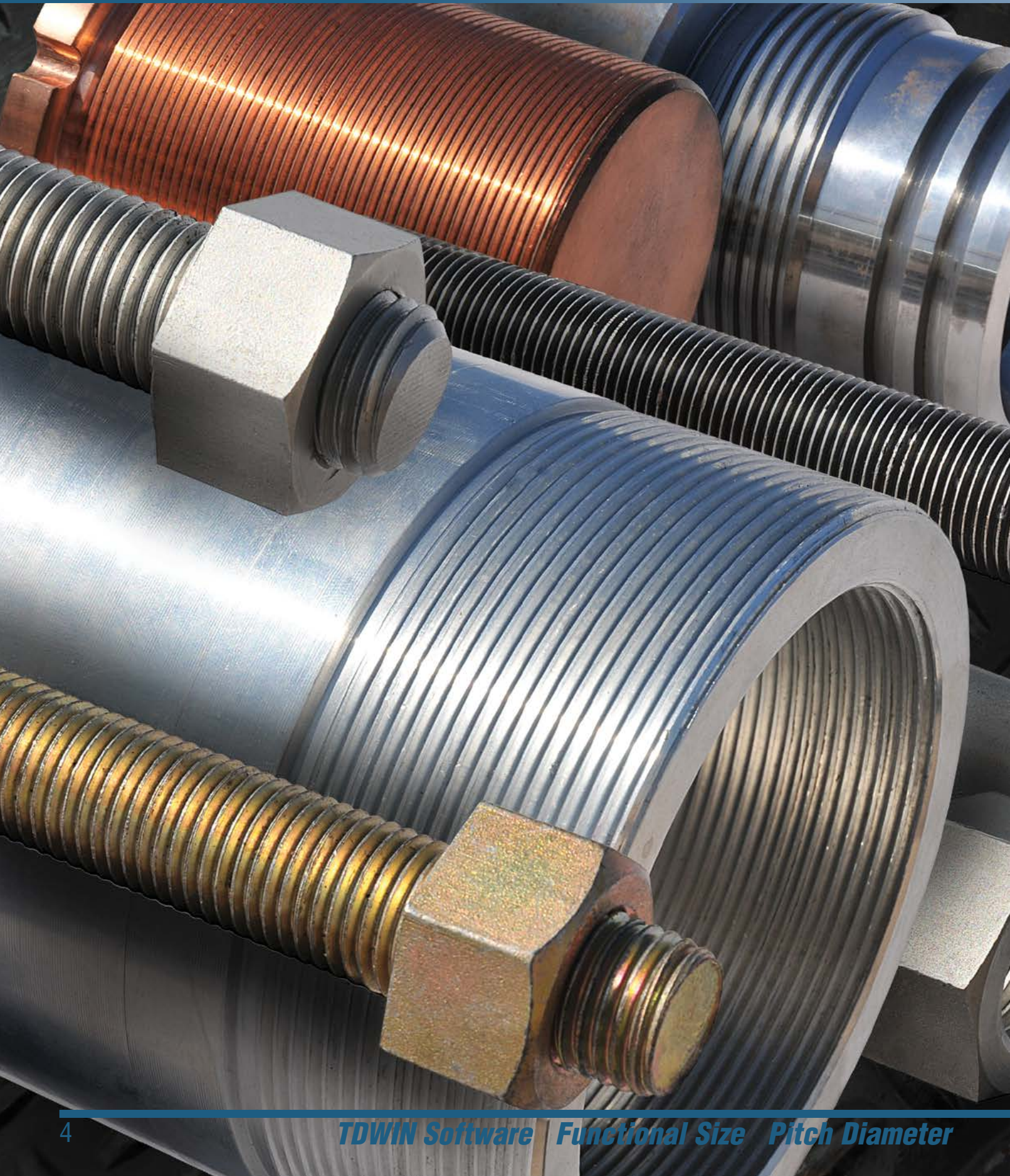



STRAIGHT THREAD GAGES



Straight Thread Inspection

Straight Thread Inspection System Solutions

Straight Thread Base System (SBP-400)

0" - 4"

- **Acme (2 - 18 pitch)**
- **Stub Acme (2 - 18 pitch)**
- **Stub Acme Mod 1 (3 - 18 pitch)**
- **Stub Acme Mod 2 (4 - 20 pitch)**
- **UN Series (2 - 28 pitch)**
- **UNR Series (2 - 28 pitch)**
- **Metric (1.5 - 4 mm pitch)**
- **7 x 45 Buttress (2 - 18 pitch)**

Base System Includes:

- External pitch diameter gage
- Internal pitch diameter gage
- External functional size gage
- Internal functional size gage
- Internal thread height gage
- External thread height gage
- Lead gage
- Lead gage standard (specify pitch)*
- Thread profile(s)*
- TDWIN software
- Two sets of thread rolls (specify form & pitch)*
- All necessary contact points (specify form & pitch)*

**Base System is for one specific form and pitch. Additional thread rolls, contact points, or standards for additional forms and pitches are available at the package price.*

4" - 8" Add-on Solution

SBP-400-1A Add-on Includes:

- RG-7001
- PD-8002
- Lead gage standard (if necessary)*
- Thread profile(s)*
- Two sets of form and pitch specific thread rolls*
- Two sets of contact points (form and pitch specific)*

**Add-on Solution is for one specific form and pitch. Additional thread rolls, contact points, profile, or standards for additional forms and pitches are available at the package price.*

For Additional Sizes and Pitches,



Full solutions for specific form, size, and pitch are available for 4" - 8" and 8" - 12".



Choose Your Add-on:

8" - 12" Add-on Solution

SBP-400-2A Add-on Includes:

- RG-7002
- PG-6001
- PD-8002
- PD-6001
- Lead gage standard (if necessary)*
- Thread profile(s)
- Two sets of form and pitch specific thread rolls*
- Two sets of contact points (form and pitch specific)*



For larger than 12" or custom sizing, please contact Gagemaker at 713-472-7360 or sales@gagemaker.com

**Add-on Solution is for one specific form and pitch. Additional thread rolls, contact points, or standards for additional forms and pitches are available at the package price.*



Straight Thread Inspection

Straight Thread Inspection System

Today's dynamic manufacturing environment overwhelms old "GO/NO GO" methods and only our Straight Thread Inspection System consistently goes above and beyond. An effective Straight Thread Inspection System should measure all of the vital thread attributes - *Functional Thread Size, Pitch Diameter, Thread Lead, Thread Height, and Thread Form.*



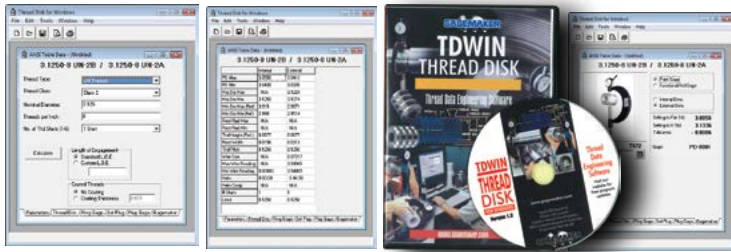

Inspection Setup & Tolerances



Functional Size



Pitch Diameter



Thread Lead



Thread Height



Thread Form



Straight Thread Inspection

Thread Inspection Setup and Tolerances

The Thread Disk™ engineering software (TDWIN™) calculates critical dimensions for threads based on ANSI tables and formulas.

Thread types supported by the program include:

- UN Series
- UNJ Series
- UNR Series
- Acme
- Stub Acme
- Stub Acme Modified I
- Stub Acme Modified II
- Metric M & MJ
- 7° X 45° Buttress
- General Purpose Pipe Threads

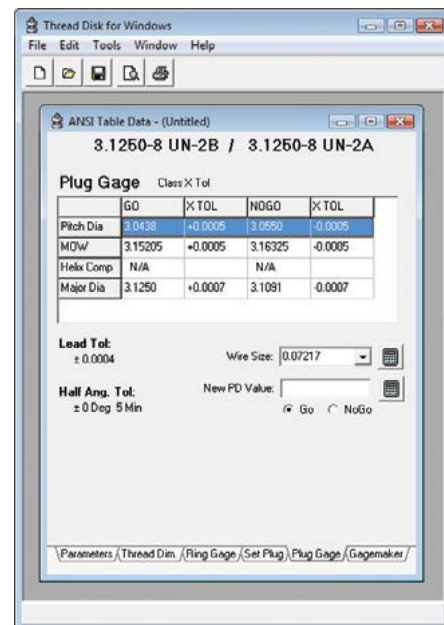

Thread Disk™ Software - Straight Thread Dimensions

To generate critical dimensions instantly, enter basic thread information on the Thread Type Entry screen, such as: thread type, thread class, nominal diameter, and threads per inch. Once the results are computed, tabs at the bottom of the program allow selection of several types of calculated information, including dimensions and tolerances for product threads, ring gages, set plugs, plug gages or Gagemaker's Thread Diameter gages.

If measuring internal and external shallow taper diameters is a problem, the Ball Mic SET DIM Tool™ provides setting dimensions for ball micrometers or Gagemaker's BX-1000 groove gage. The program calculates ball mic settings for any tapered surface geometry.

Other features of the program include the ability to print thread dimension reports, providing a paper copy of any calculation. These reports provide the same critical dimensions that display in the program. A multiple calculation window capability is a feature that allows performing several different thread calculations in one session.

System Requirements

- Windows XP or higher
- 64 MB RAM
- 3 MB of free hard disk space

Features

- Uses ANSI tables, formulas, and tolerances
- Calculates standard and non-standard product thread diameters from #000 to 99.8"
- Calculates ANSI ring and plug gage dimensions
- Addresses pitches from 1 to 400
- Calculates Gagemaker style thread gage setting dimensions

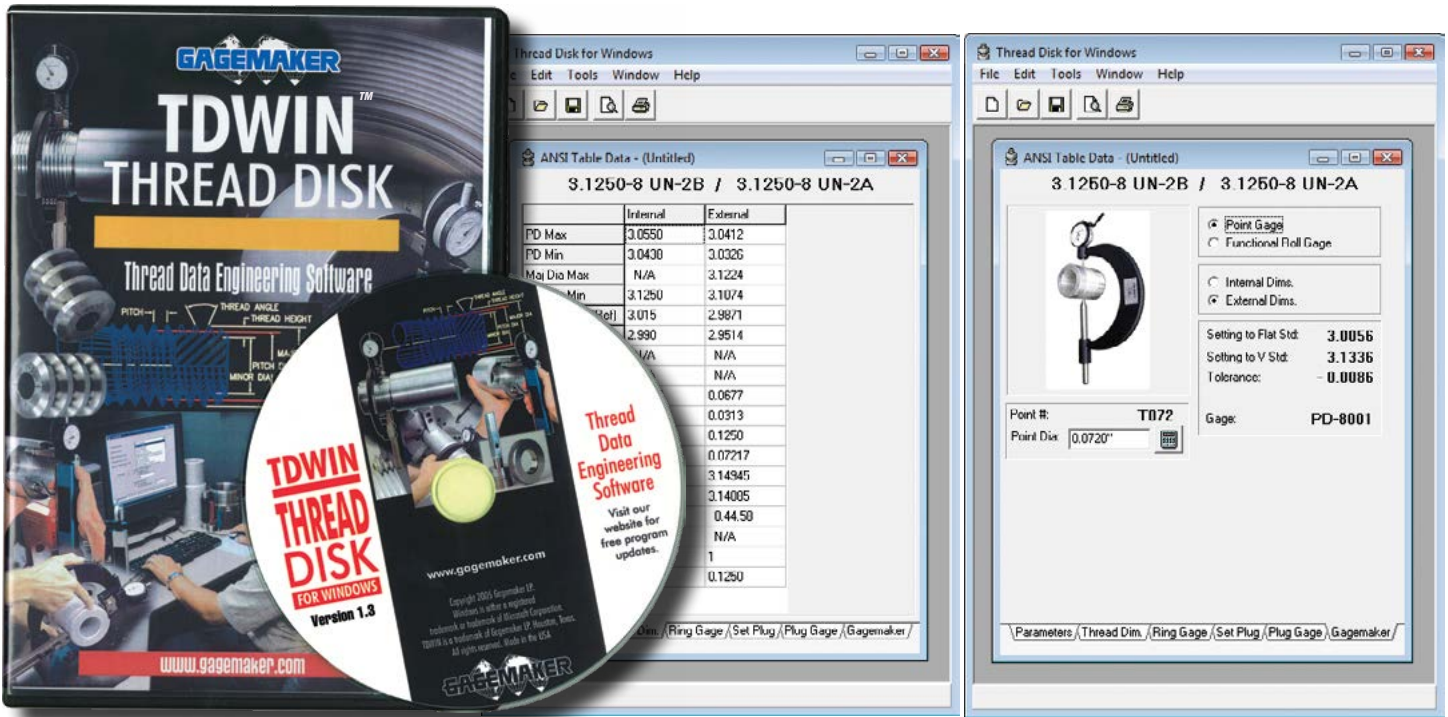

Model	Description
TDWIN	Thread Disk software
TDWIN-Network	Multi-user license agreement





Thread Functional Size Inspection

Functional gauging takes into account the cumulative effects of diameter, lead, taper, flank angle and form error. Experience the same functionality of ring and plugs with the added benefit of accurately inspecting a range of sizes.

Functional thread inspection gages, or GO/NO GO gages, measure thread diameters. These functional gages are adjustable within a size range and use interchangeable thread rolls to measure different pitch threads.

Setting dimensions for the functional pitch diameter gages are provided by the **TDWIN Thread Disk™** software.



External Functional Size Gages (5/8" to 24" Diameters)

These functional inspection gages measure external GO/NO GO thread diameters. **Software (see page 10) and thread rolls (see page 13 or 117) are sold separately.** For gages with ranges greater than 12", please see page 116. Higher resolution indicators are also available.

Model	Description	Range	Resolution	Travel
RG-7000	External Thread Roll Gage	5/8" - 4" (15.9 mm - 101.6 mm)	.0005"	1/2"
RG-7001	External Thread Roll Gage	4" - 8" (101.6 mm - 203.2 mm)	.0005"	1/2"
RG-7002	External Thread Roll Gage	8" - 12" (203.2 mm - 304.8 mm)	.0005"	1/2"

Internal Functional Size Gages (1 1/2" to 24" Diameters)

Gagemaker also manufactures functional inspection gages that inspect internal GO/NO GO thread diameters. **Software (see page 10) and thread rolls (see page 13 or 117) are sold separately.** For gages with ranges greater than 16", please see page 116. Higher resolution indicators are also available.

Model	Description	Range	Resolution	Travel
PG-6000	Internal Thread Roll Gage, 4 1/2" reach	1 1/2" - 9" (38.1 mm - 228.6 mm)	.0005"	1/2"
PG-6001	Internal Thread Roll Gage, 4 1/2" reach	9" - 16" (228.6 mm - 406.4 mm)	.0005"	1/2"
DPG-6500	Internal Deep Reach Thread Roll Gage	2.970" - 4.400"*	.0005"	1"

*DPG-6500 has extension arms to increase range up to 12.350". Please see page 116 for more information.



UN Series (60° “V”) Thread Rolls

“TRV” thread rolls inspect the functional fit of machine threaded parts with 60° “V” thread forms. These thread rolls are designed specifically for internal or external applications. Rolls are sold in matched sets (2 rolls). Specify thread pitch when ordering. Finer pitches are available upon request.

INTERNAL THREAD DIAMETERS (1½” & Larger)		EXTERNAL THREAD DIAMETERS (1½” & Larger)	
Model	Description	Model	Description
TRVI-4P	4 pitch internal 60° “V”	TRVE-4P	4 pitch external 60° “V”
TRVI-5P	5 pitch internal 60° “V”	TRVE-5P	5 pitch external 60° “V”
TRVI-6P	6 pitch internal 60° “V”	TRVE-6P	6 pitch external 60° “V”
TRVI-8P	8 pitch internal 60° “V”	TRVE-8P	8 pitch external 60° “V”
TRVI-10P	10 pitch internal 60° “V”	TRVE-10P	10 pitch external 60° “V”
TRVI-12P	12 pitch internal 60° “V”	TRVE-12P	12 pitch external 60° “V”
TRVI-14P	14 pitch internal 60° “V”	TRVE-14P	14 pitch external 60° “V”
TRVI-16P	16 pitch internal 60° “V”	TRVE-16P	16 pitch external 60° “V”
TRVI-18P	18 pitch internal 60° “V”	TRVE-18P	18 pitch external 60° “V”
TRVI-20P	20 pitch internal 60° “V”	TRVE-20P	20 pitch external 60° “V”

Acme and Stub Acme Thread Rolls

“TRA” and “TRSA” thread rolls inspect the functional fit of parts with 29° Acme and Stub Acme thread forms. Sold in matched sets of 2 rolls. Specify the pitch of the thread when ordering. Finer pitches are also available.

Acme Thread Diameters (1½” & Larger)		Stub Acme Thread Diameters (1½” & Larger)	
Model	Description	Model	Description
TRA-2P	2 pitch 29° Acme	TRSA-2P	2 pitch 29° Stub Acme
TRA-3P	3 pitch 29° Acme	TRSA-3P	3 pitch 29° Stub Acme
TRA-4P	4 pitch 29° Acme	TRSA-4P	4 pitch 29° Stub Acme
TRA-5P	5 pitch 29° Acme	TRSA-5P	5 pitch 29° Stub Acme
TRA-6P	6 pitch 29° Acme	TRSA-6P	6 pitch 29° Stub Acme
TRA-8P	8 pitch 29° Acme	TRSA-8P	8 pitch 29° Stub Acme
TRA-10P	10 pitch 29° Acme	TRSA-10P	10 pitch 29° Stub Acme
TRA-12P	12 pitch 29° Acme	TRSA-12P	12 pitch 29° Stub Acme
TRA-14P	14 pitch 29° Acme	TRSA-14P	14 pitch 29° Stub Acme
TRA-16P	16 pitch 29° Acme	TRSA-16P	16 pitch 29° Stub Acme
TRA-18P	18 pitch 29° Acme	TRSA-18P	18 pitch 29° Stub Acme

For ISO Metric Series, National 7° X 45° Buttress Series, and Trapezoidal Thread Rolls please see pages 117. Custom thread rolls are available.



Thread Pitch Diameter Inspection

Gagemaker pitch diameter gages, commonly known as ball PD gages, verify that your part is within allowable tolerances. Improperly sized pitch diameters compromise the load capacity of your threaded components.

The ball pitch diameter gages indicate the pitch diameter size of the product's external and internal threads. The gages are adjustable within a size range and use interchangeable contact points to measure different pitch threads. Setting dimensions for the pitch diameter gages are provided by the TDWIN Thread Disk™ software.

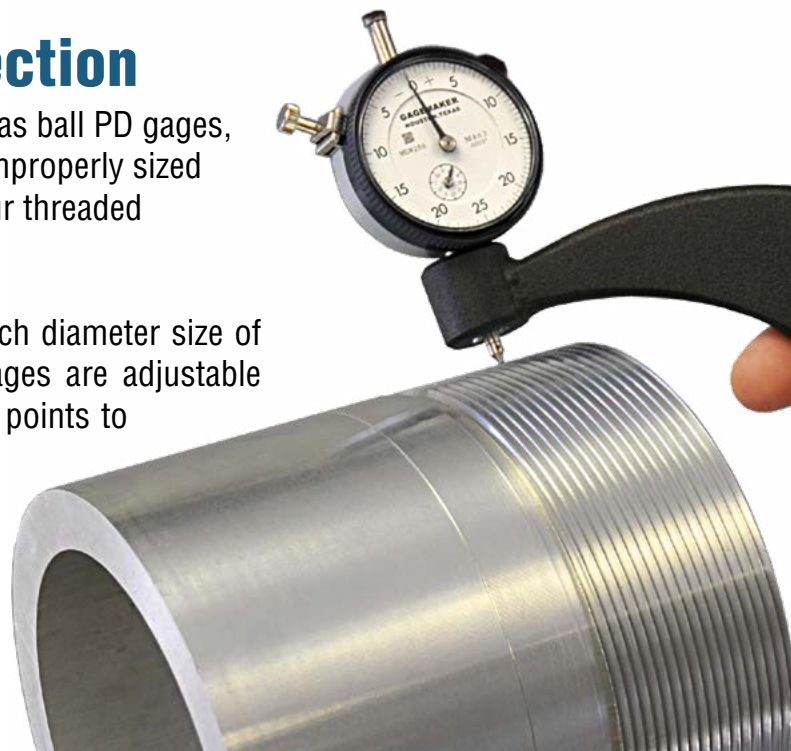

External Pitch Diameter Gages (0" to 12" Diameters)

These inspection gages measure external thread pitch diameters. **Software (see page 10) and contact points (see page 15 or 124-125) are sold separately.** For gages with ranges greater than 12", please see page 114. Higher resolution indicators are available.

Model	Description	Range	Resolution	Travel
PD-8001	External Ball Pitch Diameter Gage	0" - 6" (0 mm - 152.4 mm)	.0005"	1/2"
PD-8002	External Ball Pitch Diameter Gage	6" - 12" (152.4 mm - 304.8 mm)	.0005"	1/2"

Internal Pitch Diameter Gages (1 1/2" to 24" Diameters)

These inspection gages measure internal thread pitch diameters. **Software (see page 10) and contact points (see page 15 or 124-125) are sold separately.** Higher resolution indicators are available.

Model	Description	Range	Resolution	Travel
PD-6000	Internal Pitch Diameter Gage ("V" & Acme)	1 1/2" - 9" (38.1 mm - 228.6 mm)	.0005"	1/2"
PD-6001	Internal Pitch Diameter Gage	6" - 24" (152.4 mm - 609.6mm)	.0005"	1/2"

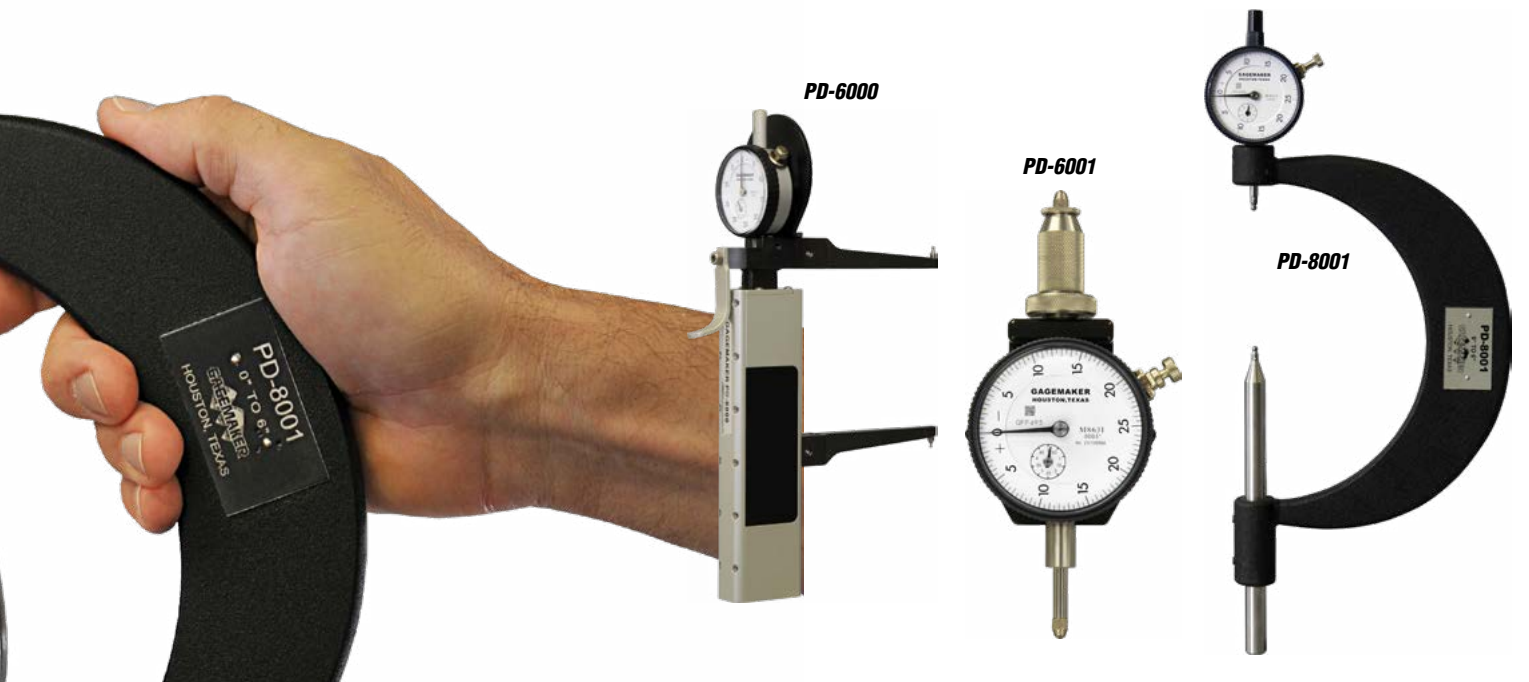

Contact Points

UN Series (60° “V”) Threads

These contact points are used to inspect the pitch diameter of machined parts with 60° “V” thread forms. Two are required per gage. Sold individually.

Model	Thread Pitch	Model	Thread Pitch	Model	Thread Pitch	Model	Thread Pitch
T562	1	T128	4.5	T072	8	T032	18
T288	2	T115	5	T057	10		
T188	3 & 3½	T105	5½	T050	11½ & 12		
T144	4	T096	6	T041	14 & 16		

Acme or Stub Acme Threads

These truncated contact points are used to inspect the pitch diameter of machined parts with 29° Acme and Stub Acme thread forms. Two are required per gage. Sold individually.

Model	Thread Pitch	Model	Thread Pitch	Model	Thread Pitch	Model	Thread Pitch
T531T	1	T188T	3	T090T	6 & 7	T032T	16
T344T	1½	T144T	3½	T062T	8		
T266T	2	T128T	4	T050T	10		
T219T	2½	T105T	5	T041T	12 & 14		

7° x 45° Buttress Series Contact Points

These contact points are used to inspect the pitch diameter of machined parts with 7° x 45° Buttress thread forms. Two are required per gage. Sold individually.

Model	Thread Pitch	Model	Thread Pitch	Model	Thread Pitch	Model	Thread Pitch
T562	1	T219	2½	T115	5	T050	12
T437	1¼	T188	3	T096	6	T032	16 & 18
T375	1½	T156	3½	T072	8		
T281	2	T144	4	T057	10		

For Trapezoidal or ISO Metric contact points please see pages 125.



Thread Lead Inspection

Thread lead is one of the most important thread elements and directly affects a part's functional size.

Lead error is most commonly generated by manual and CNC lathes not cutting properly. Therefore, it's important to take measurements at the locations where the most lead error typically occurs. These readings help detect machine tool error and worn lead screws on your lathe.

Lead gages inspect both internal and external lead on a variety of thread forms.



Lead Gages

The **LG-6002** uses a two-point system to inspect thread lead for Acme, Stub Acme, Stub Acme Modified I and II, Metric M & J, UN, UNJ, UNR, 7° X 45° Buttress, and general purpose pipe threads. The two points allow for a sweeping action to obtain the measurement.

Before inspecting parts, the lead gage must be preset to a nominal predetermined dimension using a lead gage setting standard. See chart below for the proper standard based on pitch.

Contact points are sold separately. See page 17 or 124-125 for more.

Higher resolution indicators are also available.

Model	Description	Minimum Bore	Range
LG-6002	2-point Lead Gage	1.200	½" - 4" Thread Length
LG-5003	3-point Lead Gage	1.340	½" - 4" Thread Length

Lead Gage Setting Standards

Gagemaker's precision lead gage setting standards are manufactured in accordance with ANSI Specifications. Lead gage standards are used to set the gage prior to the inspection.

Model	Connection Type/Description	Threads Per Inch (TPI)
LS-5001	Straight Threads, 1-5 pitch, 4" length	1 - 5
LS-5002	Straight Threads, 6-18 pitch, 4" length	6 - 18
LS-___mm	Straight Threads, Metric, specify pitch for model (e.g. LS-4mm)	



Contact Points

UN Series (60° “V”) Threads

These contact points are used to inspect the lead of machined parts with 60° “V” thread forms. Two are required per gage. Sold individually.

Model	Thread Pitch	Model	Thread Pitch	Model	Thread Pitch	Model	Thread Pitch
T562	1	T128	4.5	T072	8	T032	18
T288	2	T115	5	T057	10		
T188	3 & 3½	T105	5½	T050	11½ & 12		
T144	4	T096	6	T041	14 & 16		

Acme or Stub Acme Threads

These truncated contact points are used to inspect the lead of machined parts with 29° Acme and Stub Acme thread forms. Two are required per gage. Sold individually.

Model	Thread Pitch	Model	Thread Pitch	Model	Thread Pitch	Model	Thread Pitch
T531T	1	T188T	3	T090T	6 & 7	T032T	16
T344T	1½	T144T	3½	T062T	8		
T266T	2	T128T	4	T050T	10		
T219T	2½	T105T	5	T041T	12 & 14		

7° x 45° Buttress Series Contact Points

These contact points are used to inspect the lead of machined parts with 7° x 45° Buttress thread forms. Two are required per gage. Sold individually.

Model	Thread Pitch	Model	Thread Pitch	Model	Thread Pitch	Model	Thread Pitch
T562	1	T219	2½	T115	5	T050	12
T437	1¼	T188	3	T096	6	T032	16 & 18
T375	1½	T156	3½	T072	8		
T281	2	T144	4	T057	10		

For Trapezoidal or ISO Metric contact points please see pages 125.



Thread Height Inspection

Measuring thread height helps monitor and control the depth of cut during manufacturing, detects broken inserts, and can be used to calculate the minor or major diameter, when only one is known.

Accurate thread height contributes to the interchangeability and integrity of the threaded assembly.

For inspecting your straight thread heights, Gagemaker recommends our TH-3001V (external) and TH-3010 (internal) .

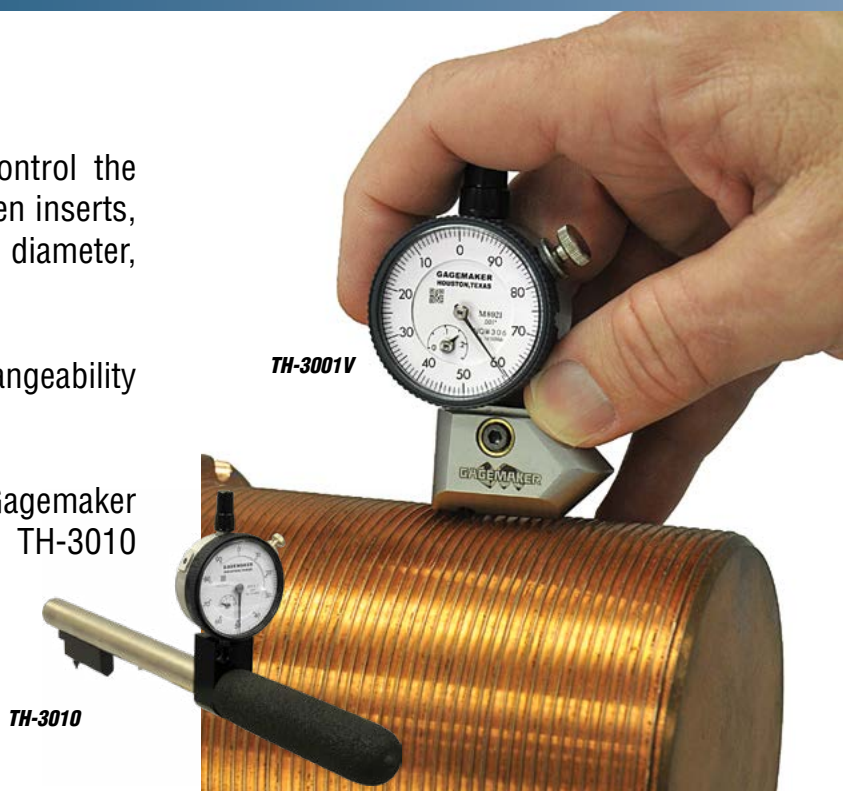

External Thread Height Gages

Gagemaker manufactures many models of external thread height gages. Specify the type of thread when ordering. The T500C contact point is included. See contact point pages on 123-125 for other options.

Model	Description	Travel	Min. Bore
TH-3001V	External Thread Height, 0-100	.196"	3.230"

Internal Thread Height Gages

Gagemaker also manufactures several models of internal thread height gages. Please specify the type of thread when ordering. The T500C contact point is included. See contact point pages on 123-125 for other options.

Model	Description	Travel	Min. Bore
TH-3010	Internal Thread Height, 0-100, 1" base	.250"	1.750"

Thread Form Inspection

Check proper form and pitch by placing the correct profile template into the threads. By shining a light behind the profile template, it's possible to detect any steps or signs of a chipped insert. A template that stands too far out of the threads or allows excess light to shine through can be an indication of lead error. Sweeping the profile template along the helix of the threads helps find burrs or debris.

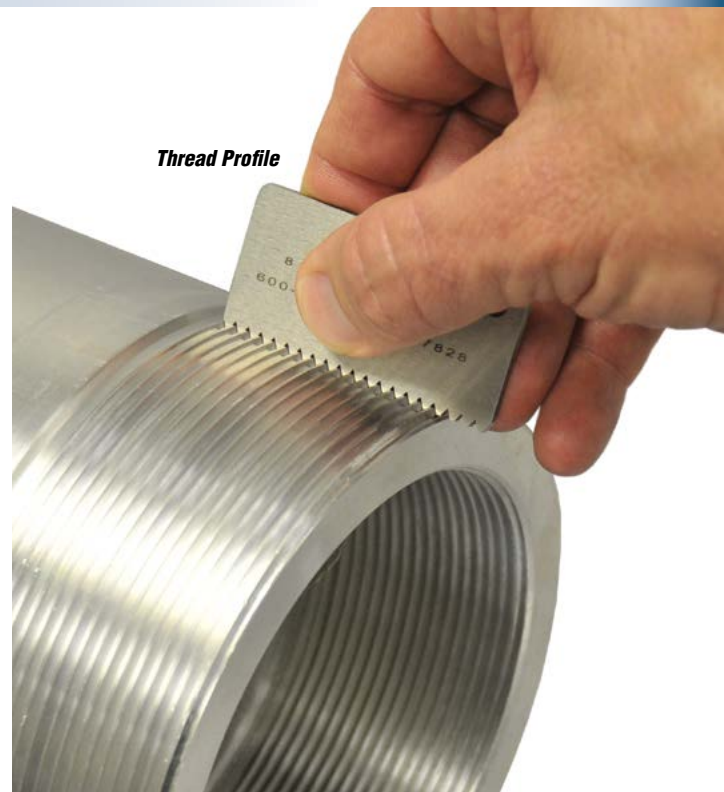

Thread Form Profiles

Gagemaker manufactures precision straight thread profile gages for the quick identification of product thread forms. Specify the pitch of the thread to be inspected when ordering. Special form profiles are available and are quoted upon request.

Model	Description
TP-UNVI-__P	Internal UN series thread gage
TP-UNVE-__P	External UN series thread gage
TP-GPA-__P	Internal/external general purpose Acme thread profile gage
TP-SA-__P	Internal/external Stub Acme thread profile gage
TP-SAM1-__P	Modified 1 Stub Acme thread profile gage
TP-SAM2-__P	Modified 2 Stub Acme thread profile gage
TP-MI-__P	Internal ISO Metric series thread profile gage
TP-ME-__P	External ISO Metric series thread profile gage
TP-745-__P	Internal/External 7° X 45° Buttress thread profile gage

Order Example: TP-UNVI-2P, TP-UNVE-4P, TP-SA-8P, etc.

Overlays for all of these profile gages are available.



Tubing & Casing Thread Inspection





TUBING & CASING GAGES



Tubing & Casing Thread Inspection

Tubing & Casing Inspection System Solutions

Basic Tubing Solution

TBP-200

2 3/8" - 4 1/2" EUE, 2 7/8" - 4 1/2" NUE



Solution Includes:

- Ovality & pitch diameter gage (MRP® Series)
- MRP® pin rod standard*
- MRP® box rod standard*
- Internal thread height gage
- External thread height gage
- Thread height standard
- Thread addendum gage
- Thread addendum standard
- Lead gage
- Lead gage standard
- Internal taper gage
- External taper gage
- Thread profile
- TDWIN Taper™ software
- All necessary contact points

**Solution package includes one pin and one box standard for one connection size. Standards for additional connection sizes are available at package price.*

Tubing Add-on Solutions

1.66" - 1.90" EUE

1.66" - 2 3/8" NUE

TBP-200-1A Add-On

- 1 MRP® pin rod standard*
- 1 MRP® box rod standard*
- TH-3012
- TP-RTC-10R profile
- Required contact points



1.05" - 1.315" EUE

1.05" - 1.315" NUE

TBP-200-2A Add-On

- MRP-202
- 1 MRP® pin rod standard*
- 1 MRP® box rod standard*
- TH-3012
- SPG-6000 with contact point arms
- TP-RTC-10R profile
- Required contact points



2 3/8" - 4 1/2" USS Buttress

TBP-200-3A Add-On

- BR-2001-USS
- 1 MRP® pin rod standard*
- 1 MRP® box rod standard*
- TH-3004-USS
- TH-3002-USS
- THS-USS
- TP-USS-8P Profile
- Required contact points



For connection packages other than the base packages, please contact Gagemaker directly. However, if you order the basic solution and want more connections, you simply need to add one of the Tubing Add-on or Casing Add-on solutions*.

**Add-on solutions include one pin and one box standard for one connection size. Standards for additional connection sizes are available at package price.*

Basic Casing Solution

CBP-300

4 1/2" - 8 5/8" LTC/STC



Solution Includes:

- Ovality & pitch diameter gage (MRP® Series)
- MRP® pin rod standard*
- MRP® box rod standard*
- Internal thread height gage
- External thread height gage
- Thread height standard
- Thread addendum gage
- Thread addendum standard
- Lead gage
- Lead gage standard
- Internal taper gage
- External taper gage
- Thread profile
- TDWIN Taper™ software
- All necessary contact points

**Solution package includes one pin and one box standard for one connection size. Standards for additional connection sizes are available at package price.*

Casing Add-on Solutions

9 5/8" - 20" STC/LTC

CBP-300-1A Add-On

- ET-7004
- ET-7006
- IT-6001 and extension rods
- 1 MRP® pin rod standard*
- 1 MRP® box rod standard*
- Required contact points



4 1/2" - 8 5/8" Buttress

CBP-300-2A Add-On

- 1 MRP® pin rod standard*
- 1 MRP® box rod standard*
- TH-3002B
- 1017 standard
- LS-1005
- BR-2001
- TP-5BTC75-EXT
- TP-5BTC75-INT
- Required contact points

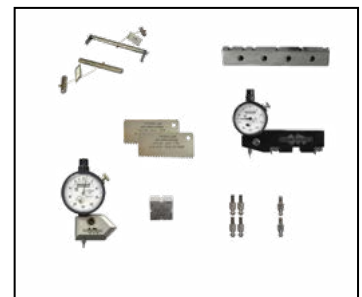

9 5/8" - 13 3/8" Buttress

CBP-300-3A Add-On

- ET-7004
- IT-6001 and extension rods
- 1 MRP® pin rod standard*
- 1 MRP® box rod standard*
- TH-3002B
- 1017 standard
- LS-1005
- BR-2001
- TP-5BTC75-INT Profile
- TP-5BTC75-EXT Profile
- Required Contact Points



16" - 20" Buttress

CBP-300-4A Add-On

- ET-7006
- IT-6001 and extension rods
- 1 MRP® pin rod standard*
- 1 MRP® box rod standard*
- TH-3003
- 1018 standard
- LS-1006
- BR-2001
- TP-5BTC1-INT
- TP-5BTC1-EXT
- Required Contact Points





Tubing & Casing Thread Inspection

Tubing & Casing Thread Inspection System

Gagemaker's Tubing & Casing Thread Inspection System takes the guesswork out of inspecting tubing and casing. The Gagemaker's Tubing and Casing Thread Inspection Gages inspect all required thread elements - *Thread Form, Ovality, Crest Diameter, Thread Lead, Thread Height, and Thread Taper* – all with the precise accuracy required in today's demanding industry.



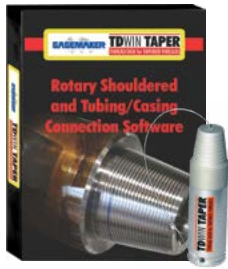

Inspection Setup & Tolerances



Thread Form



Thread Lead



Crest Diameter and Ovality



Thread Taper



Thread Height



Inspection Setup and Tolerances

TDWIN Taper™ is the perfect accessory to Gagemaker's Tubing and Casing API Inspection Gages. It's the only software program dedicated to the manufacturing and inspection of downhole tubular connections. **TDWIN Taper™** relies on API and industry standard tables and tolerances. It has everything you need to machine, inspect, and document tubular connection threads. **TDWIN Taper™** displays connection drawings, inspection gage information, and setup and inspection reports. It is a must have for any machine shop.

- *Print dimensional reports and inspection sheets*
- *Print product blueprints for manufacturing and inspection*
- *View gage configurations, setting standards, and contact point information*

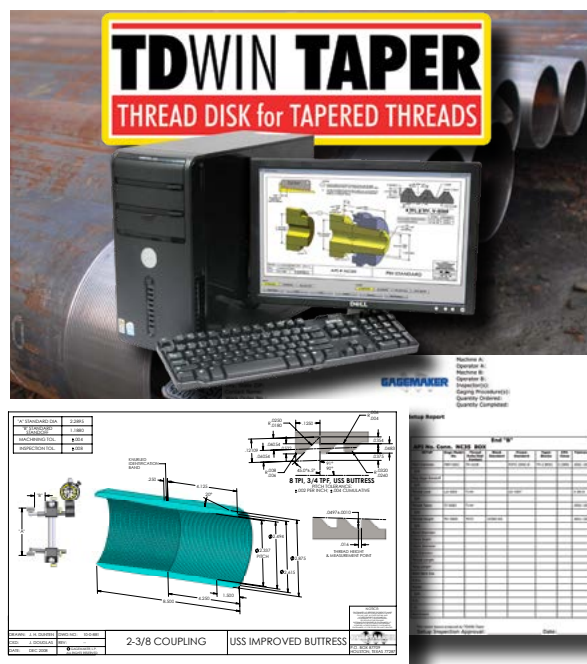

The program includes the following tapered connections:

Tubing and Casing Connections

- | | |
|---------------------|---------------------------------|
| NUE Tubing | USS Improved Buttress Tubing |
| EUE Tubing | Line Pipe |
| Short Thread Casing | Special Clearance Couplings |
| Long Thread Casing | SR13 Seal Ring Groove Couplings |
| Buttress Casing | |

Rotary Shouldered Connections

- | | | |
|-------------------------------|------------------|-------------------------|
| API Numbered Connections - NC | PAC | Slimline H-90 - SL H-90 |
| API Regular - REG | Slim Hole - SH | External Flush - EF |
| Full Hole - FH | Wide Open - WO | Acme Regular - AR |
| Internal Flush - IF | Xtra Hole - XH | Acme Streamline AS |
| Open Hole - OH | Hughes 90 - H-90 | Double Streamline - DSL |

System Requirements

- *Microsoft Windows XP or newer*
- *USB 2.0 port*
- *Internet Connection for first use*
- *1 MB RAM or more (recommended)*
- *Screen resolution of 1024 X 768 minimum*
- *.Net Framework 2.0 or later installed*

Model	Description
TDWIN-Taper-2.0	Thread Disk Software for Tapered Threads

Thread Form Inspection

Correct thread form is important for a pipe end and coupling to make up properly. Doing a quick check using a Gagemaker thread profile verifies the thread form is correct.

Profile gages can also be used to perform a visual inspection of a thread form for detecting chipped inserts, steps, flat crested threads, stretched threads, wide first threads, or rolled over threads.



TP-RTC-8R

Thread Form Profiles

Gagemaker manufactures precision tapered thread profile gages for the quick identification of product thread forms. Specify the connection which is to be inspected when ordering. Special profiles will be quoted upon request.

Model	Connection Type	Taper Per Foot (TPF)	Threads Per Inch (TPI)
TP-RTC-8R	API 8-Round Casing, Tubing & Drill Pipe	3/4"	8
TP-RTC-10R	API 10-Round Tubing	3/4"	10
TP-5BTC75-INT	API Buttress Casing, Internal, 4 1/2" - 13 3/8"	3/4"	5
TP-5BTC75-EXT	API Buttress Casing, External, 4 1/2" - 13 3/8"	3/4"	5
TP-5BTC1-INT	API Buttress Casing, Internal, 16" - 20"	1"	5
TP-5BTC1-EXT	API Buttress Casing, External, 16" - 20"	1"	5
Line Pipe, NPT, and Specials are Available Upon Request			

Overlay Charts are also available. For information, contact Gagemaker directly. Specials are also available. For Special Overlays, please specify the following:

- 1. Screen Size**
- 2. Magnification 20X/50X**
- 3. Product Form or Profile Template**



Thread Lead Inspection

Gagemaker lead gages use interchangeable contact points to inspect both pin and box threads for a wide variety of API tubing & casing connections. Lead inspection is both an API mandated requirement and an industry wide practice. Defined as the distance between threads as measured on a plane parallel to the centerline of the threaded part, lead variation has a direct effect on stand-off, thread flank engagement, and make-up. Lead error is most commonly generated by manual and CNC lathes not cutting properly. Gagemaker lead gages provide dimensional verification of product print data.



Lead Gages

The lead gage inspects both internal and external thread leads using contact points that seat in the threads of a part. The pitch of the thread determines the diameter of the contact points required for taking measurements.

The **LG-6001** (external) and the **LG-6002** (internal) are two-point gages for inspecting thread lead on API threads. The two points allow for a sweeping action to obtain the measurement.

The **LG-5003** is a three-point gage for inspecting thread lead on API threads. Two fixed contact points at the rear of the gage and one moveable contact point at the front of the gage provide complete stability when taking thread lead measurements. This unique design does not require sweeping to obtain measurements.

Contact points can be easily changed to allow the gages to be used on a variety of thread forms. For tubing and casing, please see page 29 for contact points. Additional points can be found on pages 124-125.

Before inspecting parts, the lead gage must be preset to a nominal predetermined dimension using a lead gage setting standard. For tubing and casing, please see page 29 for standards.

More gage models and accessories can be found on pages 120-121. Higher resolution indicators are available.

Model	Description	Minimum Bore	Range
LG-6001	External Lead Gage 2-point	1.200	½" - 2" Thread Length
LG-6002	Internal Lead Gage 2-point	1.200	½" - 4" Thread Length
LG-5003	Lead Gage 3-point Contact point spacing .500"	1.340	½" - 4" Thread Length



LG-5003

Lead Gage Setting Standard

Gagemaker’s precision lead gage setting standards are manufactured in accordance with API Specification 5B. Lead gage standards are used to set the gage prior to the inspection.

Model	Connection Type/Description	TPF*	TPI*
LS-1001	API 8-Round Casing, Tubing & Drill Pipe, All 10-Round Tubing	¾"	8 & 10
LS-1005	API Buttress Casing, Internal/External 4½" - 13¾"	¾"	5
LS-1006	API Buttress Casing, Internal/External 16" - Larger	1"	5



*TPF = Taper Per Foot, TPI = Threads Per Inch

API Contact Points for Lead Gages

Gagemaker’s standard ball contact points are manufactured with carbide balls. Both threaded and straight (non-threaded) shanks are available. All of Gagemaker’s inspection gages use threaded shank contact points and are #4-48 UNF. Metric threads are available upon request. Lead gages require two or three contact points. Contact points are sold individually.

Model	Point Diameter	Threads Per Inch	Connection Type
T090	0.090"	5	Buttress Casing – Taper
T072	0.072"	8	API Tubing and Casing
T062	0.062"	5	Buttress Casing – Lead
T057	0.057"	10	API Tubing

*Line Pipe and NPT contact points and standards are available. For contact points, see pages 124-125. For standards, see page 121.



Crest Diameter and Ovality Inspection

Thirty years ago, Gagemaker introduced the **MRP**[®] gage which forever changed the industry. Today, the **MRP**[®] is the industry standard worldwide. Whether you call it Crest Diameter, Root Diameter, or Ball PD, Pitch Diameter governs the strength of the actual thread assembly and ensures API dimensional measurement specs are met.

The Gagemaker **MRP**[®] gages measure the internal and external pitch diameters of tapered threaded connections. Any slight variations in diameter or ovality are immediately detected with these precision gages granting you total control over your quality. These versatile gages easily adjust to measure thread diameters ranging from 1½" - 20". The ability to inspect a range of diameters with one gage, eliminates the need for a room full of ring or plug gages.



MRP[®] Crest Diameter and Ovality Gages

The **MRP**[®] series of gages detects variations in crest diameter by the use of a gage shoe that rests on the crest of the threads. Variation in diameter is detected by the indicator readout. These gages must be set to a nominal size with one of a variety of setting standards or a MIC TRAC[™]. Refer to the standard chart that follows. All of these gages are API approved for use on tubing and casing. **Additional gages, parts, & accessories can be found on pages 104-109.**

Model	Description	Range
MRP-1001	External Crest Diameter Gage	External 1½" - 4½"
MRP-1002	Internal Crest Diameter Gage	External 1½" - 4½"
MRP-1000	Internal/External Crest Diameter Gage	Internal 1½" - 4½" External 1½" - 4½"
MRP-2001	External Crest Diameter Gage	External 2¾" - 20"
MRP-2002	Internal Crest Diameter Gage	Internal 2¾" - 20"
MRP-2003	Internal/External Crest Diameter Gage, ¼" reach	Internal 2¾" - 20" External 2¾" - 20"

Rod Style Setting Standards for MRP-1000 and MRP-2000 Series

Rod style setting standards are designed to preset all models of the **MRP**[®] Series gages for accurate inspection of API threaded connections. Each set of standards consists of two precision ground rods that are ground to lengths in accordance with API Specification 5B. Other standard styles and connections are available, see pages 108-109.

Thread Type	Connection	Pin Standard Model	Box Standard Model
NUE	2¾" NUE	MRP5B-238NUE-P	MRP5B-238NUE-B
	2⅞" NUE	MRP5B-278NUE-P	MRP5B-278NUE-B
	3½" NUE	MRP5B-312NUE-P	MRP5B-312NUE-B
	4" NUE	MRP5B-4NUE-P	MRP5B-4NUE-B
	4½" NUE	MRP5B-412NUE-P	MRP5B-412NUE-B
EUE	2¾" EUE	MRP5B-238EUE-P	MRP5B-238EUE-B
	2⅞" EUE	MRP5B-278EUE-P	MRP5B-278EUE-B
	3½" EUE	MRP5B-312EUE-P	MRP5B-312EUE-B
	4" EUE	MRP5B-4EUE-P	MRP5B-4EUE-B
	4½" EUE	MRP5B-412EUE-P	MRP5B-412EUE-B



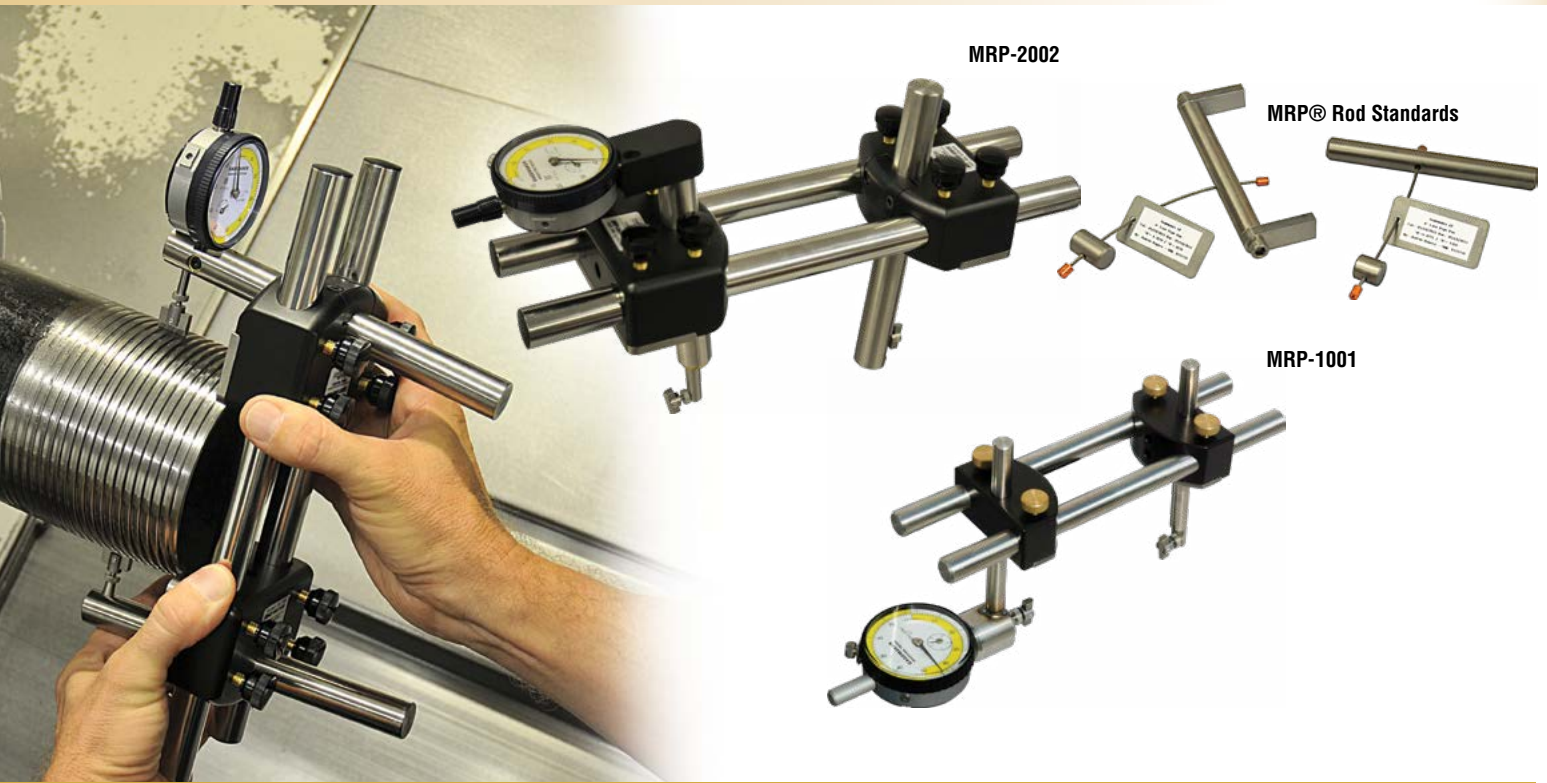

Rod Style Setting Standards (Cont'd.)

Thread Type	Connection	Pin Standard	Box Standard
Buttress	4½" Buttress	MRP5B-412B-P	MRP5B-412B-B
	5" Buttress	MRP5B-5B-P	MRP5B-5B-B
	5½" Buttress	MRP5B-512B-P	MRP5B-512B-B
	6¾" Buttress	MRP5B-658B-P	MRP5B-658B-B
	7" Buttress	MRP5B-7B-P	MRP5B-7B-B
	7¾" Buttress	MRP5B-758B-P	MRP5B-758B-B
	8¾" Buttress	MRP5B-858B-P	MRP5B-858B-B
	9¾" Buttress	MRP5B-958B-P	MRP5B-958B-B
	10¾" Buttress	MRP5B-1034B-P	MRP5B-1034B-B
	11¾" Buttress	MRP5B-1134B-P	MRP5B-1134B-B
	13¾" Buttress	MRP5B-1338B-P	MRP5B-1338B-B
	16" Buttress	MRP5B-16B-P	MRP5B-16B-B
	18¾" Buttress	MRP5B-1858B-P	MRP5B-1858B-B
20" Buttress	MRP5B-20B-P	MRP5B-20B-B	
LTC	4½" 8R LTC	MRP5B-412L-P	MRP5B-412L-B
	5" 8R LTC	MRP5B-5L-P	MRP5B-5L-B
	5½" 8R LTC	MRP5B-512L-P	MRP5B-512L-B
	6¾" 8R LTC	MRP5B-658L-P	MRP5B-658L-B
	7" 8R LTC	MRP5B-7L-P	MRP5B-7L-B
	7¾" 8R LTC	MRP5B-758L-P	MRP5B-758L-B
	8¾" 8R LTC	MRP5B-858L-P	MRP5B-858L-B
	9¾" 8R LTC	MRP5B-958L-P	MRP5B-958L-B>P110 or MRP5B-958L-B<P110
	20" 8R LTC	MRP5B-20L-P	MRP5B-20L-B>JK55 or MRP20L-B<JK55

Thread Type	Connection	Pin Standard	Box Standard
STC	4½" - 9.50# 8R STC	MRP5B-412S-9-P	MRP5B-412S-9-B
	4½" - Other 8R STC	MRP5B-412S-0-P	MRP5B-412S-0-B
	5" - 11.50# 8R STC	MRP5B-5S-11-P	MRP5B-5S-11-B
	5" - Other 8R STC	MRP5B-5S-0-P	MRP5B-5S-0-B
	5½" 8R STC	MRP5B-512S-P	MRP5B-512S-B
	6¾" 8R STC	MRP5B-658S-P	MRP5B-658S-B
	7" - 17.00# 8R STC	MRP5B-7S-17-P	MRP5B-7S-17-B
	7" - Other 8R STC	MRP5B-7S-0-P	MRP5B-7S-0-B
	7¾" 8R STC	MRP5B-758S-P	MRP5B-758S-B
	8¾" - 24.00# 8R STC	MRP5B-858S-24-P	MRP5B-858S-24-B
	8¾" - Other 8R STC	MRP5B-858S-0-P	MRP5B-858S-0-B
	9¾" 8R STC	MRP5B-958S-P	MRP5B-958S-B>P110 or MRP5B-958S-B<P110
	10¾" - 32.75# 8R STC	MRP5B-1034S-32-P	MRP5B-1034S-32-B
	10¾" - Other 8R STC	MRP5B-1034S-0-P	MRP5B-1034S-0-B>P110 or MRP5B-1034S-0-B<P110
	11¾" 8R STC	MRP5B-1134S-P	MRP5B-1134S-B>P110 or MRP5B-1134S-B<P110
	13¾" 8R STC	MRP5B-1338S-P	MRP5B-1338S-B>P110 or MRP5B-1338S-B<P110
	16" 8R STC	MRP5B-16S-P	MRP5B-16S-B
	18¾" 8R STC	MRP5B-1858S-P	MRP5B-1858S-B
	20" 8R STC	MRP5B-20S-P	MRP5B-20S-B>JK55 or MRP20S-B<JK55

Line Pipe, NPT, step style, and frame style standards are available.
All Special Orders, Non-Standard API Standards, or Premium Connection Setting Standards are extra.



Thread Taper Inspection

Tapered threads are a signature feature of API Tubing & Casing connections. Measuring thread taper is not only an industry wide practice, it is an API Specification 5B mandated inspection. During the manufacturing process, taper must be accurately measured and quantified to stay within the required specification limits. When subjected to a service load, taper error on threaded tubing and casing connections can lead to galling, improper fit, and reduced performance.

For the most accurate taper inspection, use Gagemaker taper gages to verify both the threaded pin and coupling meet all customer and industry requirements. Gagemaker's taper gages are the best choice for measuring and controlling both pin and box taper values.

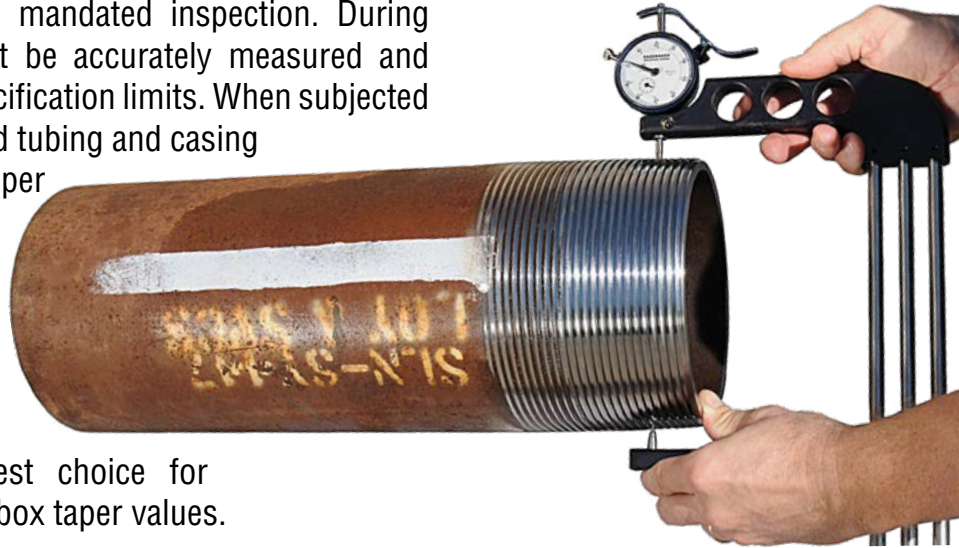

External Taper Gages

Gagemaker's external taper gages inspect variation in external thread taper. Unless specified otherwise, external taper gages are shipped with .072" diameter contact points (T072) as standard. Refer to the chart on the following page for the proper contact point for your particular connection. Each gage requires two contact points. Higher resolution indicators are available.

Model	Description	Range	Travel	Resolution
ET-7001	External Taper, 1/2" travel	0" - 6"	1/2"	.001"
ET-7002	External Taper, 1/2" travel	0" - 10"	1/2"	.001"
ET-7003	External Taper, 1" travel	0" - 10"	1/2"	.001"
ET-7004	External Taper, 1/2" travel	0" - 16"	1/2"	.001"
ET-7006	External Taper, 1/2" travel	16" - 24"	1/2"	.001"

Internal Taper Gages

Gagemaker's internal taper gages measure variation in thread taper. Taper gages are shipped with our standard set of .072" diameter contact points (T072), unless specified otherwise or requested. Refer to the chart on the following page for the proper contact point for your particular connection. Each internal gage requires two contact points. Higher resolution indicators are available.

Model	Description	Range	Travel	Resolution
IT-6000	Internal Taper Gage	4 1/4" Depth, 1 1/2" - 9" Diameter	1"	.001"
IT-6001	Internal Taper Gage	Any Depth, 5" - 13 3/8" API Sizes	1/2"	.001"



API Contact Points for Taper Gages

Gagemaker’s standard ball contact points are manufactured with carbide balls. All of Gagemaker’s inspection gages use threaded shank contact points. Threaded shanks are #4-48 UNF. Metric threads are available upon request. Taper gages require two contact points. Additional contact points can be found on pages 124-125.

Model	Point Diameter	Threads Per Inch (TPI)	Connection Type
T090	0.090"	5	Buttress Casing – Taper
T072	0.072"	8	API Tubing and Casing
T057	0.057"	10	API Tubing and Line Pipe



Thread Height Inspection

Proper Thread Height maximizes the performance of the connection. Thread height inspection is an API requirement. Gagemaker thread height gages inspect external or internal thread height for a variety of thread forms. A shallow thread height may allow the connection to pull apart under stress.



External Thread Height Gages

Gagemaker manufactures many models of external thread height gages. Specify the type of thread when ordering. One contact point based on thread type is included, please refer to the chart on page 35. For tubing and casing, standards may be required, please see page 35 for more.

Model	Description	Connection	Travel	Min. Bore
TH-3002B	External Thread Height, 0-25-0	3/4" TPF Buttress	.094"	2.930"
TH-3002R	External Thread Height, 0-50-0	8-Round & 10-Round	.162"	3.400"

Internal Thread Height Gages

Gagemaker also manufactures several models of internal thread height gages. Please specify the type of thread when ordering. One contact point based on thread type is included, please refer to the chart on page 35. For tubing and casing, standards may be required, please see page 35 for more.

Model	Description	Connection	Travel	Min. Bore
TH-3006	Internal Thread Height, 0-25-0	8-Round & 10-Round	.105"	1.595"
TH-3008	Internal Thread Height, 0-25-0	8-Round & 10-Round	.094"	1.575"
TH-3009	Internal Thread Height, 0-25-0	3/4" TPF Buttress	.250"	1.750"



Thread Height Gage Standards

Gagemaker manufactures API mandated precision setting standards for presetting thread height gages. Please specify the type of thread when ordering.

Model	Description
THS-1014	8 & 10 Round Threads
THS-1017	13 $\frac{3}{8}$ " & Smaller Buttress, $\frac{3}{4}$ " TPF
THS-1018	16" & Larger Buttress, 1" TPF

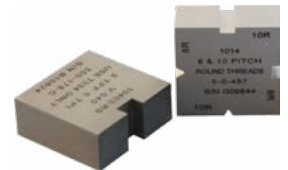

Thread Height Gage Contact Points

The contact points are interchangeable between gages. Contact point diameters are manufactured to tolerances of $\pm .0002$ ". Thread height gages require one contact point. Additional points are available, please see pages 123-124.

Model	Description
T072	0.072" Contact Point for Buttress Threads
T501	50° Cone Contact Point, Self-Centering for TH-3001R, TH-3002R Gages
T502	Self-Centering Sleeve for T501 & T503 Contact Points
T503	50° Cone Contact Point, "V" Threads for TH-3006



Rotary Shouldered Connection Thread Inspection



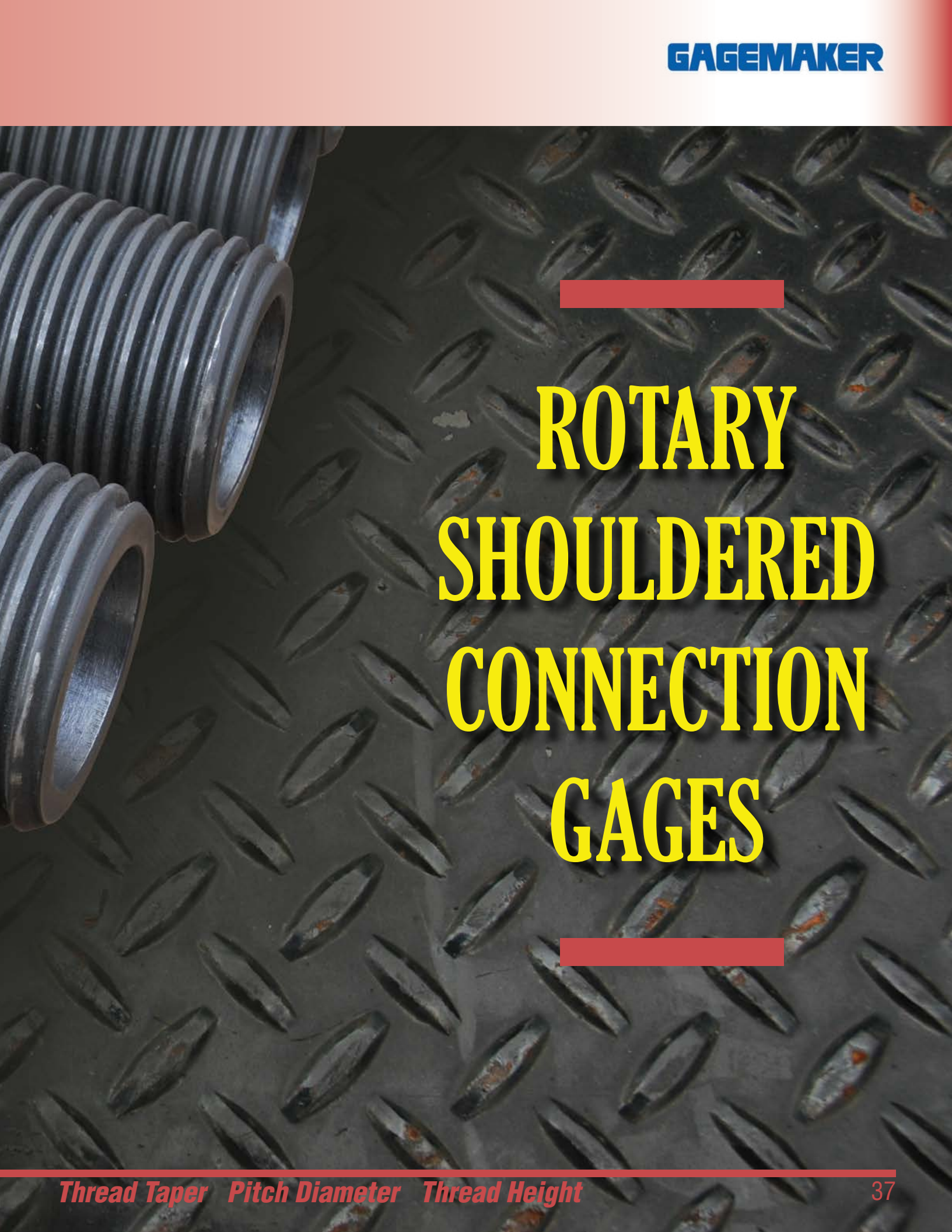

**ROTARY
SHOULDERED
CONNECTION
GAGES**



Rotary Shouldered Connection Thread Inspection

Choose Your

JSS® Solutions

Inspect the following Connections:

- API No. Connection (NC) - 23, 26, 31, 35, 38, 40, 44, 46, 50
- Double Streamline - 3½", 4, 4½", 5½"
- External Flush - 3½", 4½"
- Full Hole - 4"
- Internal Flush - 2¾", 2⅞", 3½", 4, 4½"
- Slim Hole - 2¾", 2⅞", 3½", 4, 4½"
- Xtra Hole - 2⅞", 3½", 4½", 5"

FIELD SOLUTION

JSS-100

Field Solution Includes:

- External pitch diameter gage
- Internal pitch diameter gage
- Location profiles for box
- Location profile for pin
- Lead gage and standard
- External taper gage
- Internal taper gage
- Thread height gages and standard
- Thread profiles
- TDWIN Taper™ Software
- 1 external rod standard*
- 1 internal rod standard*
- Necessary contact points

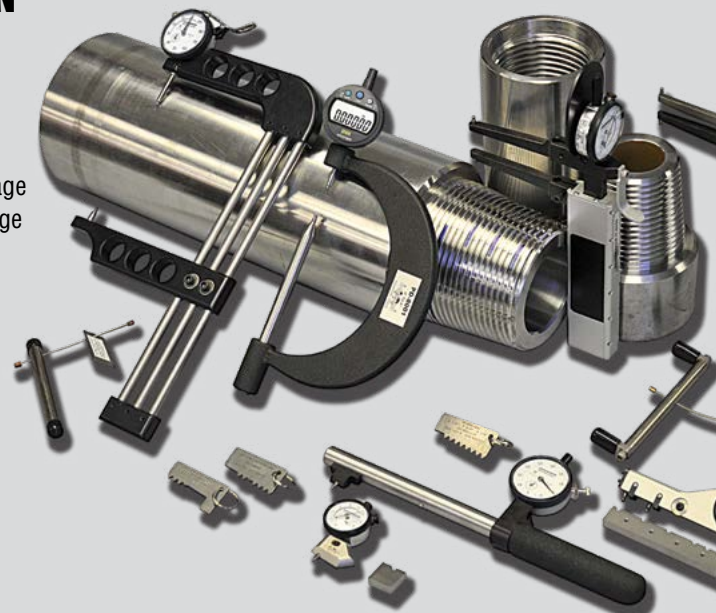

*Field Solution includes one pin and one box standard for one connection size.
Rod standards for additional connection sizes are available at solution price at time of package order.

For Additional Connections,

Connections

IF - 5½", 6⅞"

EF - 2¾", 2⅞"

FH - 2⅞", 3½", 4½"
REG - 2¾", 2⅞", 3½", 4½"

REG - 5½", 7⅞", 8⅞"

FH - 5½", 6⅞"***
REG - 6⅞"

H - 90 - 3½", 4", 4½",
5", 5½", 6⅞"

JSS-100 Field Solution Add-ons

JSS-100-1A

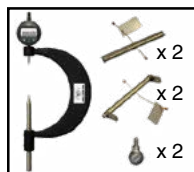

JSS-100-2A

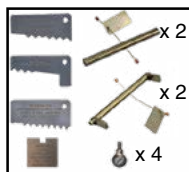

JSS-100-3A

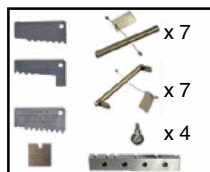

JSS-100-4A

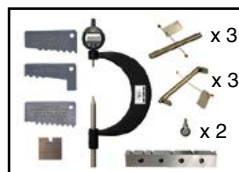

JSS-100-5A

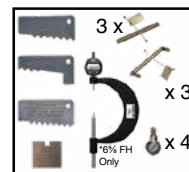

JSS-100-6A

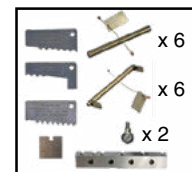

JSS-500 Shop Solution Add-ons

JSS-500-1A



JSS-500-2A



JSS-500-3A



JSS-500-4A



JSS-500-5A



JSS-500-6A



Base Package:

SHOP SOLUTION JSS-500

Shop Solution Includes:

- External pitch diameter gage
- Internal pitch diameter gage
- Location profile for box
- Location profile for pin
- Lead gage and standard
- External taper gage
- Internal taper gage
- Thread height gage and standard
- Thread profiles
- TDWIN Taper™ software
- MIC TRAC™ (MT-3000)
- Necessary contact points

OR



Choose Your Add-ons:

H - 90 - 7", 7 $\frac{1}{8}$ ", 8 $\frac{1}{2}$ "

SL H-90 - 2 $\frac{3}{8}$ ", 2 $\frac{7}{8}$ ", 3 $\frac{1}{2}$ "

NC - 10, 12, 13, 16
REG - 1", 1 $\frac{1}{2}$ "

NC - 56, 61, 70, 77

PAC - 2 $\frac{3}{8}$ ", 2 $\frac{7}{8}$ ", 3 $\frac{1}{2}$ "
OH - 2 $\frac{3}{8}$ ", 2 $\frac{7}{8}$ ", 3 $\frac{1}{2}$ ", 4", 4 $\frac{1}{2}$ "

JSS-100-7A

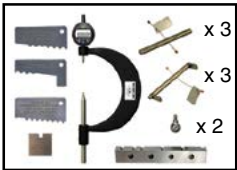

JSS-100-8A



JSS-100-9A



JSS-100-10A



JSS-100-11A



JSS-500-7A



JSS-500-8A



JSS-500-9A



JSS-500-10A



JSS-500-11A





Rotary Shouldered Connection Thread Inspection

Rotary Shouldered Connection Thread Inspection System

Gagemaker's Joint Strength System (JSS®) is a revolutionary breakthrough in accurately gauging the quality of both *new* and *used* rotary shouldered connections. It's now possible to avoid broken connections by identifying thread damage before it's visually apparent and unfortunately too late. For years, the industry has relied on the interpretative "fit" of a ring or plug gage although a ring or plug gage will not directly detect variation in pitch diameter. With JSS®, you'll inspect just a few key attributes and save hours of down time and thousands of dollars in rework charges.

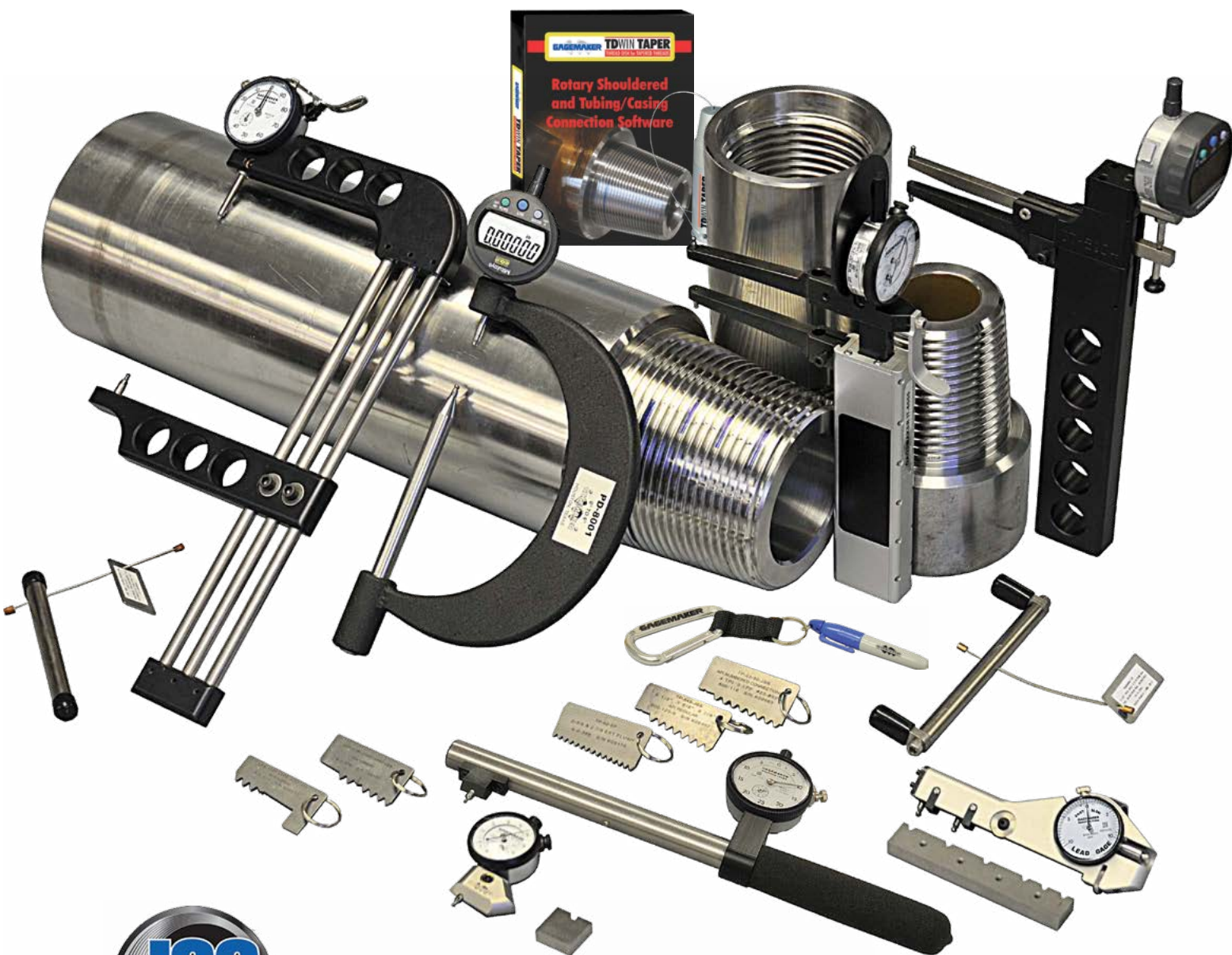

**ROTARY SHOULDERED
THREAD INSPECTION SYSTEM**



Inspection Setup and Tolerances



Insert Identification

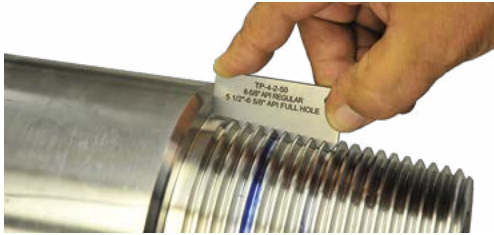

Thread Form



Pitch Diameter



Thread Lead



Thread Taper



Thread Height



Inspection Setup and Tolerances

TDWIN Taper™ is the only software program dedicated to the manufacturing and inspection of downhole tubular connections. It has everything you need to machine, inspect, and document tubular connection threads. TDWIN Taper™ relies on API and industry standard tables and tolerances. TDWIN Taper™ displays connection drawings, inspection gage information, and setup and inspection reports. Simply, it is a must have for any machine shop.

TDWIN Taper™ is included in any full JSS® Package.

- Follows API Specification 7-2, Dec. 2008, for Rotary Shouldered Connections and API Specification 5B, Oct. 2008, for Tubing and Casing Connections
- Print product blueprints for manufacturing and inspection
- Print dimensional reports and inspection sheets
- Provides gages configurations, setting standards, and contact point information



The program includes the following tapered connections:

Tubing and Casing Connections

- | | |
|---------------------|---------------------------------|
| NUE Tubing | USS Improved Buttress Tubing |
| EUE Tubing | Line Pipe |
| Short Thread Casing | Special Clearance Couplings |
| Long Thread Casing | SR13 Seal Ring Groove Couplings |
| Buttress Casing | |

Rotary Shouldered Connections

- | | | |
|-------------------------------|------------------|-------------------------|
| API Numbered Connections - NC | PAC | Slimline H-90 - SL H-90 |
| API Regular - REG | Slim Hole - SH | External Flush - EF |
| Full Hole - FH | Wide Open - WO | Acme Regular - AR |
| Internal Flush - IF | Xtra Hole - XH | Acme Streamline AS |
| Open Hole - OH | Hughes 90 - H-90 | Double Streamline - DSL |

System Requirements

- Microsoft Windows XP or newer
- USB 2.0 port
- Internet Connection for first use
- 1 MB RAM or more (recommended)
- Screen resolution of 1024 X 768 minimum
- .Net Framework 2.0 or later installed

Model	Description
TDWIN-Taper-2.0	Thread Disk Software for Tapered Threads

TDWIN TAPER THREAD DISK for TAPERED THREADS



Date: 6/8/2009 11:31:02 AM
 Customer:
 Address 1:
 Address 2:
 City, State ZIP:
 Contact Name:
 Work Order No.:
 Customer PO:
 Drawing No/Rev:
 Description:

Machine A:
 Operator A:
 Machine B:
 Operator B:
 Inspector(s):
 Gauging Procedure(s):
 Quantity Ordered:
 Quantity Completed:

End "A"						End "B"					
API No.	Conn.	NC35	PIN	Block Standard	Form Standard	API No.	Conn.	NC35	BOX	Block Standard	Form Standard
Pitch Diameter	48P-0001	78-4126		P107-200C-P	TP-2-000C	Pitch Diameter	48P-0001	78-4126		P107-200C-B	TP-2-000C
Flug Gauge Standoff						Flug Gauge Standoff					
Thread Lead	LG-5002	T144		LG-1007		Thread Lead	LG-5002	T144		LG-1007	
Thread Taper	ET-7000	T144		ET020-000		Thread Taper	ET-7000	T144		ET020-000	
Thread Height	TH-3000RSC	R072		TH000-010		Thread Height	TH-3000RSC	R072		TH000-010	
Base Diameter						Base Diameter					
Core Diameter						Core Depth					
Shoulder Length						Core Diameter					
Thread Length						Core Diameter					
Tang Length						Thread Length					
Root Wash Dia.						Tang Length					
O.A.S.						Root Wash Dia.					
O.S.						O.A.S.					
Profile						O.S.					
Lead						I.O.					
Benchmark						Benchmark					

Notes: This report based produced by Taper Taper Setup Inspection Approval: Date:

End B
 STANDARD
 BLANKING
 RELIEF GRV
 MOD BORE

API # NC50 PIN STANDARD

The oilfield's most reliable source of information to accurately machine, inspect, and document tapered threaded connections

Consulting TDWIN Taper™ should be your first step in quality assurance. Until now, this type of information was available only through closely controlled documents supplied by a few industry leaders. Now, all the latest dimensions, gauging tolerances, and inspection reports for the connections you need to cut are available with a few keystrokes.

Stay on top of the ongoing changes in industry specifications with your own copy of the TDWIN Taper™ program.





Insert Identification

The first step in the quality process is to ensure the threading insert being used is correct for the job.

Use a Thread Insert Identifier Template to quickly verify that the correct threading insert has been selected as well as check the full topping profile of both internal and external inserts.

A quick mating of the insert to the template ensures the insert is correct for the job.

Insert identifiers have multiple notches on each template and are available for all API thread forms.

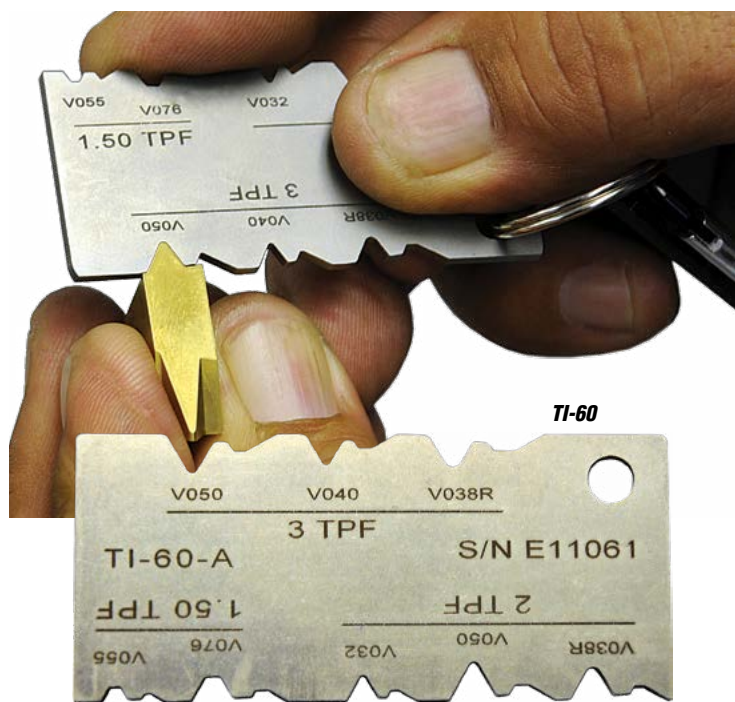

Tapered Insert Identifiers

Gagemaker's new tapered thread insert identifier easily determines which threading insert the machinist is using. When an optical comparator is unavailable, the insert identifier will show which thread form is on the insert.

Model	TPF	Thread Forms
TI-RSC-60	1.5", 2", & 3"	V-0.032, V-0.038R, V-0.040, V-0.050, V-0.055, V-0.076
TI-RSC-90	1.25", 2", 3", & 3.373"	A-0.094, 90-V-0.050, 90-V-0.084

Thread Form Inspection

Thread form accuracy is important if two connections are to make-up properly. Using a Thread Profile Gage provides a quick check of the thread to ensure that the form is correct. The Thread Profile should be used on every connection to ensure the first imperfect thread was deburred fully.

Thread form is defined as its profile in an axial plane for a length of one pitch. Most importantly, verifying thread form is a recommended inspection for API connections and ensures form accuracy.

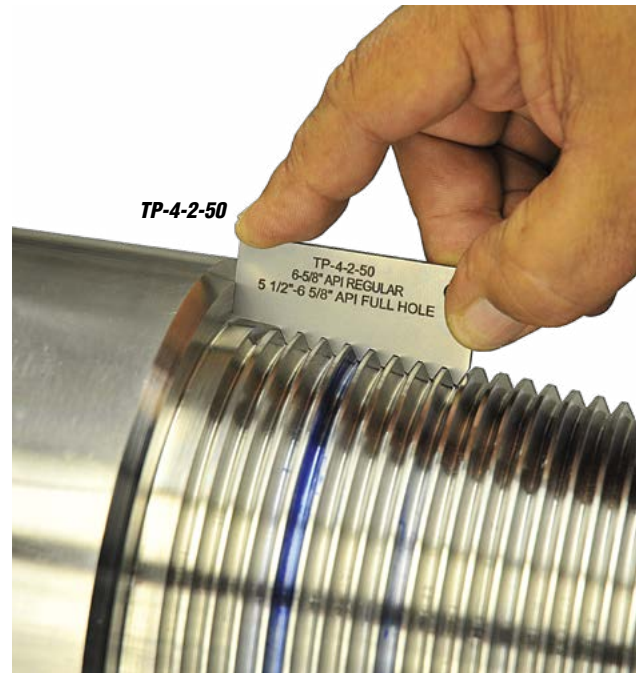

Thread Profile Gages

Gagemaker manufactures precision tapered thread profile gages for the quick identification of product thread forms. Specify the connection which is to be inspected when ordering. Special profiles will be quoted upon request.

Model	Connection Type	TPI, TPF, Thread Form
TP-3-1.25-84	2 $\frac{3}{8}$ " - 3 $\frac{1}{2}$ " Hughes Slimline H-90	3 TPI, 1.25" TPF, 90-V-0.084
TP-3.5-2-50	3 $\frac{1}{2}$ " - 6 $\frac{5}{8}$ " Hughes H-90	3.5 TPI, 2" TPF, 90-V-0.050
TP-3.5-3-50	7" - 8 $\frac{5}{8}$ " Hughes H-90	3.5 TPI, 3" TPF, 90-V-0.050
TP-4-1.5-76	2 $\frac{3}{8}$ " - 3 $\frac{1}{2}$ " P.A.C. Connections 2 $\frac{3}{8}$ " - 4 $\frac{1}{2}$ " American Open Hole	4 TPI, 1.5" TPF, V-0.076
TP-4-2-50	6 $\frac{5}{8}$ " API REG 5 $\frac{1}{2}$ " & 6 $\frac{5}{8}$ " API Full Hole	4 TPI, 2" TPF, V-0.050
TP-4-2-38	3 $\frac{1}{2}$ " - 5 $\frac{1}{2}$ " Double Streamline, 3 $\frac{1}{2}$ " - 4 $\frac{1}{2}$ " External Flush, 4" API Full Hole, 2 $\frac{3}{8}$ " - 4 $\frac{1}{2}$ " Hughes Slim Hole, 2 $\frac{7}{8}$ " - 5" Hughes Xtra Hole, 2 $\frac{3}{8}$ " - 6 $\frac{5}{8}$ " Internal Flush 2 $\frac{3}{8}$ " - 4 $\frac{1}{2}$ " Wide Open API Numbered Connections #23 - #50	4 TPI, 2" TPF, V-0.038R
TP-4-3-38	API Numbered Connections #56 - #77	4 TPI, 3" TPF, V-0.038R
TP-4-3-50	5 $\frac{1}{2}$ ", 7 $\frac{5}{8}$ ", & 8 $\frac{5}{8}$ " API REG	4 TPI, 3" TPF, V-0.050
TP-5-3-40	2 $\frac{3}{8}$ " - 4 $\frac{1}{2}$ " API REG 2 $\frac{7}{8}$ ", 3 $\frac{1}{2}$ ", 4 $\frac{1}{2}$ " API Full Hole	5 TPI, 3" TPF, V-0.040
TP-6-1.5-55	API Numbered Connections #10, #12, #13, #16 M.T. (Macaroni Tubing)	6 TPI, 1.5" TPF, V-0.055
TP-6-2-32	2 $\frac{3}{8}$ " - 2 $\frac{7}{8}$ " Hughes External Flush	6 TPI, 2" TPF, V-0.032

Special profiles and overlay charts are available. For information on those available, please contact customer service. For Special Overlays, please specify the following: 1. Screen Size, 2. Magnification 20X/50X, and 3. Product Form or Profile Template



Thread Pitch Diameter Inspection

Now, operators are able to inspect both new and used pipe threads using precision Pitch Diameter Gages that allow them to pinpoint early signs of stress, perform preventative maintenance, and extend the life of their drill string connections. By measuring the pitch diameters, the operators can directly control the connection's size during manufacturing, as well as ensure that the thread cones go into interference properly when the connections are torqued together.

In the past, pitch diameter has been ignored as long as the ring or plug gage threaded to an acceptable standoff. Using a pin location profile (LPP) and a PD-8000-RSC Series gage(pin) or a box location profile (LPB) with an IT-5104-RSC (box) provides you plenty of control. The process of locating and measuring the pitch diameter takes less than a minute. This minute of inspection quickly decides the difference between good quality and bad quality.



Pitch Diameter Location Templates

Pitch diameter location templates locate the point on the connection where the pitch diameter is measured. When applied properly to the connection, the template's special layout mark indicates the proper thread to measure the pitch diameter. A simple mark with a felt tip marking pen allows the operator or inspector to accurately position the gage and read a diameter. Please specify the threads per inch (TPI), taper per foot (TPF), and thread form when ordering.

Box Pitch Diameter Location Templates

Model	Thread Form	Model	Thread Form
LPB-3-1.25-SLH9	3 TPI, 1.25 TPF, 90-V-0.084	LPB-4-3-50	4 TPI, 3 TPF, V-0.050
LPB-3.5-2-H9	3.5 TPI, 2 TPF, 90-V-0.050	LPB-4-3.375-A-0.094	4 TPI, 3.375 TPF, A-0.094
LPB-3.5-3-H9	3.5 TPI, 3 TPF, 90-V-0.050	LPB-5-3-40	5 TPI, 3 TPF, V-0.040
LPB-4-1.5-76	4 TPI, 1.50 TPF, V-0.076	LPB-6-1.0-55	6 TPI, 1.0 TPF, V-0.055
LPB-4-2-38	4 TPI, 2 TPF, V-0.038R	LPB-6-1.5-55	6 TPI, 1.50 TPF, V-0.055
LPB-4-2-50	4 TPI, 2 TPF, V-0.050	LPB-6-2-32	6 TPI, 2 TPF, V-0.032
LPB-4-3-38	4 TPI, 3 TPF, V-0.038R		

Pin Pitch Diameter Location Templates

Model	Thread Form	Model	Thread Form
LPP-3-1.25-SLH9	3 TPI, 1.25 TPF, 90-V-0.084	LPP-4-3-50	4 TPI, 3 TPF, V-0.050
LPP-3.5-2-H9	3.5 TPI, 2 TPF, 90-V-0.050	LPP-4-3.375-A-0.094	4 TPI, 3.375 TPF, A-0.094
LPP-3.5-3-H9	3.5 TPI, 3 TPF, 90-V-0.050	LPP-5-3-40	5 TPI, 3 TPF, V-0.040
LPP-4-1.5-76	4 TPI, 1.50 TPF, V-0.076	LPP-6-1.0-55	6 TPI, 1.0 TPF, V-0.055
LPP-4-2-38	4 TPI, 2 TPF, V-0.038R	LPP-6-1.5-55	6 TPI, 1.50 TPF, V-0.055
LPP-4-2-50	4 TPI, 2 TPF, V-0.050	LPP-6-2-32	6 TPI, 2 TPF, V-0.032
LPP-4-3-38	4 TPI, 3 TPF, V-0.038R		



Internal Pitch Diameter Gages

Gagemaker's internal pitch diameter gages measure variation in internal thread pitch diameters. Pitch diameter gages are shipped with one set of contact points, please see the chart below to request proper points. Setting dimensions for the pitch diameter gages are provided by the TDWIN Taper™ software package. Gages require setting with either a standard or a MIC TRAC™. **Software (page 42), MIC TRAC™ (pages 87-93), contact points, and standards (page 113) are sold separately.**

Model	Description	Range
IT-5104-RSC	Internal Pitch Diameter Gage	4" (101.6 mm) Depth, 1½" - 10" (38.1 mm - 254 mm) Diameter

External Pitch Diameter Inspection Gages

The ball pitch diameter gages indicate the pitch diameter size of the product's external thread. The gages are adjustable within a size range and use interchangeable contact points to measure different pitch threads. Gages ship with one set of contact points, please see the chart below to request proper points. Gages require setting with either a standard or a MIC TRAC™. **Software (page 42), MIC TRAC™ (pages 87-93), contact points, and standards (page 113) are sold separately.**

Model	Description	Range
PD-8001-RSC	External Pitch Diameter Gage	0" - 6" (0 mm - 152.4 mm)
PD-8002-RSC	External Pitch Diameter Gage	6" - 12" (152.4 mm - 304.8 mm)

API Contact Points for Pitch Diameter Gages

Gagemaker's standard ball contact points are manufactured with carbide balls. All RSC inspection gages use threaded shank contact points. Threaded shanks are #4-48 UNF. Pitch diameter gages require two contact points. Sold individually.

Model	Point Diameter	Threads Per Inch	Connection Type
T235	0.235"	3	Hughes Slim Line H-90
T200	0.200"	3½	All Hughes H-90
T144	0.144"	4	API Rotary Shouldered Connections
T115	0.115"	5	API Rotary Shouldered Connections
T096	0.096"	6	API Rotary Shouldered Connections



Thread Lead Inspection

Thread Lead is one of the most important thread elements to monitor. Not only is lead inspection an industry wide practice for rotary shouldered connections, it is an API Specification 7 mandated requirement. Lead error is most commonly generated by manual and CNC lathes not cutting properly.

Thread lead is the distance between threads, measured on a plane parallel to the centerline of the threaded part. Lead error has a direct effect on functional diameter, stand-off, and thread flank engagement.

Gagemaker's lead gages inspect pin and box connections for multiple pitches and thread forms. The gages provide dimensional verification of product print data on the thread's true integrity.

- *Interchangeable contact points allow inspection on a variety of thread forms.*
- *Inspect RSC threads as well as Tubing and Casing threads.*
- *Requires presetting using Gagemaker's lead gage setting standards.*

Lead Gages

The **LG-6001** (external) and the **LG-6002** (internal) are two-point gage for inspecting thread lead for API threads. The two points allow for a sweeping action to obtain the measurement.

The **LG-5003** is a three-point gage for inspecting thread lead on API threads. Two fixed contact points at the rear of the gage and one moveable contact point at the front of the gage provide complete stability when taking thread lead measurements. This unique design does not require sweeping to obtain measurements.

Contact points can be easily changed to allow the gage to be used on a variety of thread forms. Lead gages come with two contact points. Please specify type of points required when ordering, see page 44 for chart.

Before inspecting parts, the lead gage must be preset to a nominal predetermined dimension using a lead gage setting standard. Please see the chart on page 44 to select your standard. Standards are not included.

Model	Description	Minimum Bore	Range
LG-6001	External Lead Gage 2-point	1.200	½" - 2" Thread Length
LG-6002	Internal Lead Gage 2-point	1.200	½" - 4" Thread Length
LG-5003	Lead Gage 3-point Contact point spacing .500"	1.340	½" - 4" Thread Length



LG-6001

Lead Gage Setting Standards

Gagemaker's precision lead gage setting standards are manufactured in accordance with API Specification 7-2. Lead gage standards are used to set the gage prior to the inspection.

Model	Connection Type/Description	TPF*	TPI*
LS-1007	6 $\frac{1}{2}$ " API Reg; 4", 5 $\frac{1}{2}$ ", & 6 $\frac{1}{2}$ " API Full Hole; 2 $\frac{7}{8}$ ", 3 $\frac{1}{2}$ " - 5" Hughes Xtra Hole; 2 $\frac{3}{8}$ ", 2 $\frac{7}{8}$ " - 4 $\frac{1}{2}$ " Hughes Slim Hole; 2 $\frac{3}{8}$ " - 5 $\frac{1}{2}$ " API INT Flush; API Numbered Connections #23-#50	2"	4
LS-1008	5 $\frac{1}{2}$ ", 7 $\frac{1}{8}$ " - 8 $\frac{1}{8}$ " API Reg, API Numbered Connections #56 - #77	3"	4
LS-1009	2 $\frac{3}{8}$ " - 4 $\frac{1}{2}$ " API Reg, 3 $\frac{1}{2}$ ", 4 $\frac{1}{2}$ " API Full Hole	3"	5
LS-1010	API Numbered Connections #10, #12, #13, #16 A.M.T. (Macaroni Tubing) 2 $\frac{3}{8}$ " - 3 $\frac{1}{2}$ " PAC 2 $\frac{3}{8}$ " - 4" American Open Hole	1 $\frac{1}{2}$ "	4
LS-1011	3 $\frac{1}{2}$ " - 6 $\frac{1}{8}$ " Hughes H-90	2"	3 $\frac{1}{2}$
LS-1012	7" - 8 $\frac{1}{8}$ " Hughes H-90	3"	3 $\frac{1}{2}$
LS-1013	2 $\frac{3}{8}$ " - 3 $\frac{1}{2}$ " Slim Line H-90	1 $\frac{1}{4}$ "	3

*TPF = Taper Per Foot, TPI = Threads Per Inch

API Contact Points for Lead Gages

Gagemaker's standard ball contact points are manufactured with carbide balls. All Gagemaker lead gages use threaded shank contact points. Threaded shanks are #4-48 UNF. Lead gages require two or three contact points. See pages 124-125 for additional contact points.

Model	Point Diameter	Threads Per Inch	Connection Type
T235	0.235"	3	Hughes Slim Line H-90
T200	0.200"	3 $\frac{1}{2}$	All Hughes H-90
T144	0.144"	4	API Rotary Shouldered Connections
T128	0.128"	4 $\frac{1}{2}$	API Rotary Shouldered Connections
T115	0.115"	5	API Rotary Shouldered Connections
T096	0.096"	6	API Rotary Shouldered Connections



Thread Taper Inspection

Thread Taper is the change in pitch diameter over the length of a connection, typically designated in inches per foot. For all rotary shouldered connections, measuring thread taper is not only an industry wide practice; it is an API mandated inspection.

During the manufacturing process, taper must be accurately measured and quantified to avoid mismatched tapers. When under a service load, mismatched tapers between pins and boxes diminish proper thread engagement resulting in reduced connection performance.

Gagemaker's IT-6000 and ET-7000 series gages are the best choice for measuring and controlling both pin and box taper values within the required specification limits. When RSC connections are properly manufactured utilizing Gagemakers precision taper gages, product performance is maximized.

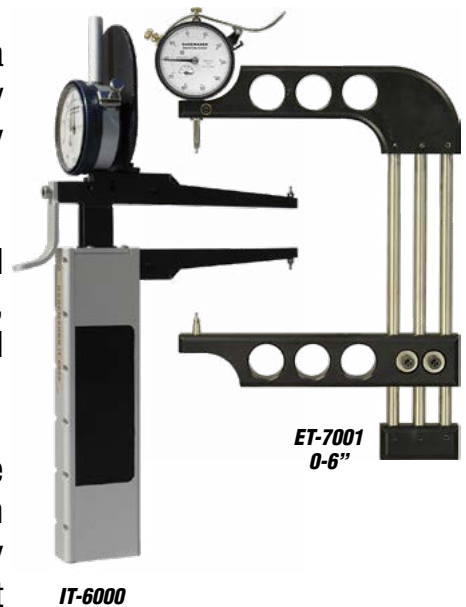

External Taper Gages

Gagemaker's external taper gages inspect variation in connection taper. External taper gages are shipped with .072" diameter contact points unless otherwise requested. Refer to the contact point chart on the next page for the proper contact point for your particular connection. Higher resolution indicators are available. For larger diameters, see page 115.

Model	Description	Range	Travel	Resolution
ET-7003	External Taper Gage	0" - 10"	1"	.001"

Internal Taper Gages

Gagemaker's internal taper gages measure variation in connection taper. Taper gages are shipped with our standard set of .072" diameter contact points, unless specified otherwise. Refer to the contact point chart on the next page for the proper contact point for your particular connection. Higher resolution indicators are available. For larger diameters, see page 115.

Model	Description	Range	Travel	Resolution
IT-6000	Internal Taper Gage, 4¼" Depth	1½" - 9" Diameter	1"	.001"

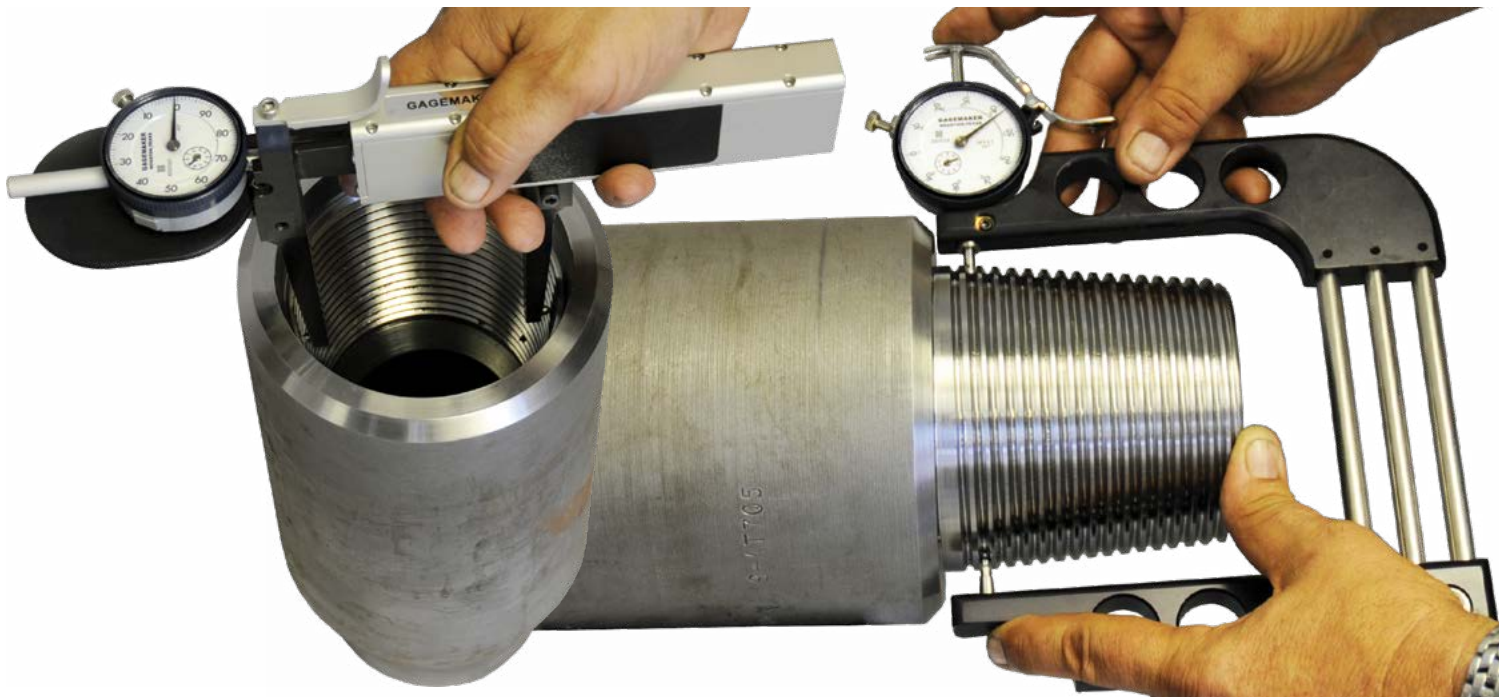

API Contact Points for Taper Gages

Gagemaker’s standard contact points are manufactured with carbide balls. Taper gages use threaded shank contact points. Threaded shanks are #4-48 UNF. For other contact points, please see pages 124-125. Taper gages require two contact points. Sold individually.

Model	Point Diameter	Threads Per Inch (TPI)	Connection Type
T235	0.235"	3	Hughes Slim Line H-90
T200	0.200"	3½	All Hughes H-90
T144	0.144"	4	API Rotary Shouldered Connections
T115	0.115"	5	API Rotary Shouldered Connections
T096	0.096"	6	API Rotary Shouldered Connections



Thread Height Inspection

Proper thread height maximizes the performance of any threaded connection and is a required inspection by the API. Thread height not only affects the interchangeability but also the integrity of a thread assembly. Thread height is the distance between the crest and the root, normal to the axis of the thread and several issues can be easily detected by simply inspecting thread height.

From detecting a chipped tool to preventing a connection from pulling apart under critical loads, inspecting thread height is valuable. Thread Height Gages inspect both internal and external thread height for a variety of thread forms and provide immediate feedback on the integrity of your threads.



External Thread Height Gages

Gagemaker manufactures external thread height gages. Please specify the thread form when ordering. One contact point (T072) included, please see chart on page 53 for the proper point for your connection. Standards sold separately, please see page 53.

Model	Description	Connection	Travel	Min. Bore
TH-3000-RSC	External Thread Height, 0-25-0	Rotary Shouldered Connections	.196"	3.230"

Internal Thread Height Gages

Gagemaker also manufactures internal thread height gages. Please specify the thread form when ordering. One contact point (T072) included, please see chart on page 53 for proper point for your connection. Standards sold separately, please see page 53.

Model	Description	Connection	Travel	Min. Bore
TH-3009-RSC	Internal Thread Height, 0-25-0, 1" Base	Rotary Shouldered Connections	.250"	1.750"



Thread Height Gage Standards

Gagemaker manufactures precision setting standards for thread height gages to API specifications. Please specify the type of thread when ordering.

Model	Description
THS-10322	V-0.032, 2 TPF, 6 TPI to be used with T034 pt.
THS-10382	V-0.038R, 2 TPF, 4 TPI to be used with T072 pt.
THS-10383	V-0.038R, 3 TPF, 4 TPI to be used with T072 pt.
THS-10403	V-0.040, 3 TPF, 5 TPI to be used with T034 pt.
THS-10502	V-0.050, 2 TPF, 4 TPI to be used with T044 pt.
THS-10503	V-0.050, 3 TPF, 4 TPI to be used with T044 pt.
THS-10551.5	V-0.055, 1.5 TPF, 6 TPI to be used with T072 pt.
THS-10761.5	V-0.076, 1.5 TPF, 4 TPI to be used with T044 pt.
THS-10H90-2	2" TPF H-90 Connection (90-V-0.050), 3.5 TPI to be used with T072 pt.
THS-10H90-3	3" TPF H-90 Connection (90-V-0.050), 3.5 TPI to be used with T072 pt.
THS-SL-H90	1¼" TPF, 3 TPI, 90-V-0.084 to be used with T072 pt.

Thread Height Contact Points

Gagemaker's standard contact points are manufactured with carbide balls. Thread height gages require one contact point. Points are sold individually.

Model	Point Diameter	Threads Per Inch	Thread Form
T072	0.072"	3, 3.5, 4, 6	V-0.038R, V-0.055
T044	0.044"	4	V-0.050, V-0.076
T034	0.034"	5, 6	V-0.032, V-0.040



Premium Connection Inspection

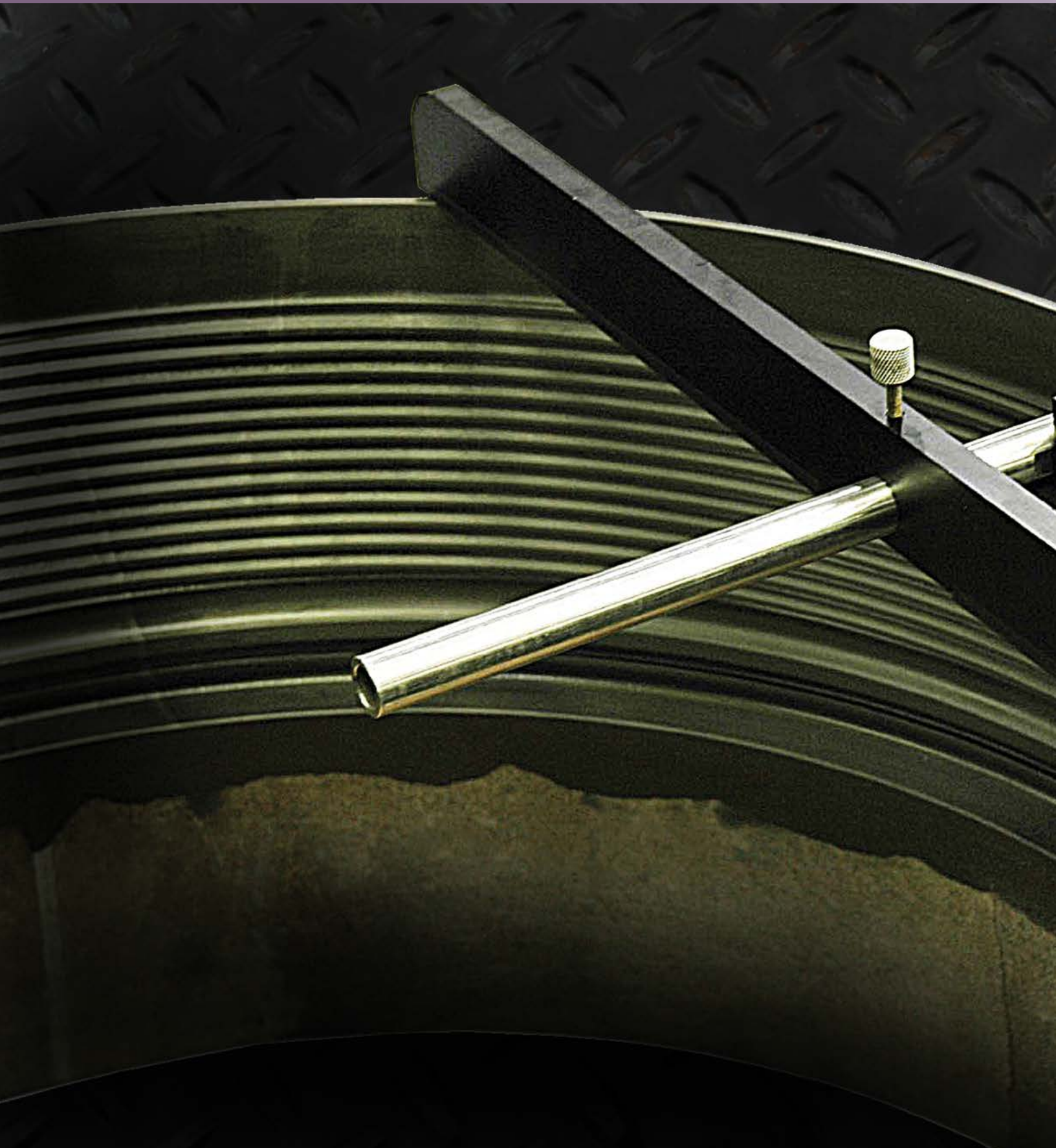



PREMIUM CONNECTION GAGES



Premium Connection Inspection Gages

As drilling requirements become more difficult and as the demand for performance increases, companies respond with new and improved connection designs to meet those customer demands. When companies design new proprietary connections their first call is to Gagemaker to discuss gauging requirements. Over the past 25 years Gagemaker has designed and built gauging solutions that ensure consistent quality of premium connections. Many of the gages have multiple applications and can be shipped with short lead times. This section of the catalog is focused on those specialty gages that apply directly to the premium or non-API connection industry.



CONFIDENTIALITY STATEMENT

Gagemaker maintains confidentiality of all proprietary connection designs through signed agreements. Gagemaker will not provide any quotations nor ship any gages or setting standards to any unauthorized party. Customers doing work for companies that require proprietary gages will be required to submit approval in writing prior to receiving any quotes or gages.



Thread Diameter Gages



Shoulder Location Gages



Pipe Straightness Gages



Seal Gages



Thread Runout Gages



Thread Diameter Gages

A variety of comparative style thread inspection gages are available for the proprietary market. We provide gages that will meet your requirements of size range, accuracy, affordability, and delivery.

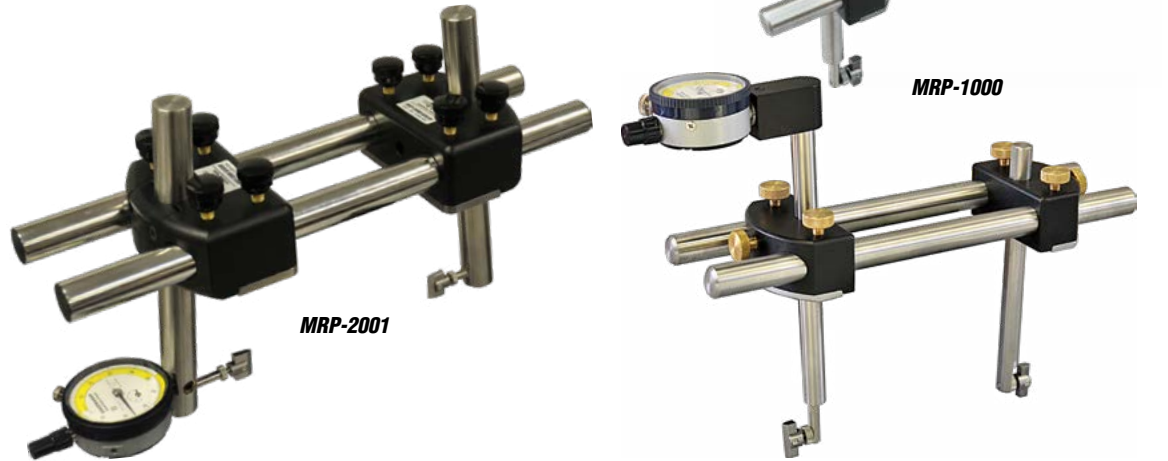

MRP® Pitch Diameter and Ovality Gages

This MRP® series of pitch diameter gages detects variations in pitch diameter by the use of a gage shoe that rests on the crest of the threads. Variation in diameter is detected by the indicator readout. These gages must be set to nominal size with one of a variety of setting options offered. Refer to the setting option section that follows. All of these gages are API approved for use on casing and tubing.

Model	Description	Range
MRP-1000	Internal/External Pitch Diameter Gage	1½" - 4½"
MRP-1001	External Pitch Diameter Gage	External 1½" - 4½"
MRP-1000-45	Internal Seal Diameter Gage. Contacts on a 45° angle. Arms- .375" upper, .375" lower	Internal 1" - 4½"
MRP-1007	Internal Seal Diameter Gage. Contacts on a 45° angle. Arms- .740" upper, .500" lower	Internal 1½" - 4½"
MRP-1008	Internal Seal Diameter Gage. Contacts on a 45° angle. Arms- .740" upper, .740" lower	Internal 1¾" - 4½"
MRP-1009	Internal Seal Diameter Gage. Contacts on a 45° angle. Arms- .740" upper, .500" lower	Internal 1¾" - 4½"
MRP-1012-TSS	Internal/External Pitch Diameter Gage for Two Step Seal. Upper and lower arms are .740" diameter. Upper arm has standard travel of .150". Shipped with T105 pts.	Internal 2¾" - 4½" External 1¾" - 4½"
MRP-1012-TST	Internal/External Pitch Diameter Gage, Two Step Thread, w/ 1.030" Horseshoe standoff for front and rear measurements. Upper and lower arms have .740" diameter. Upper arm has extended travel of .350"	Internal 2¾" - 4½" External 1¾" - 4½"
MRP-1500	Internal/External Pitch Diameter Gage, Solid Body	Internal 1½" - 4½" External 2¾" - 4½"
MRP-2001	External Pitch Diameter Gage	External 2¾" - 20"
MRP-2001-S	External Pitch Diameter Gage, 4½" reach, Straight Blocks	
MRP-2001-7	External Pitch Diameter Gage, 7" reach	
MRP-2001-10	External Pitch Diameter Gage, 10" reach	

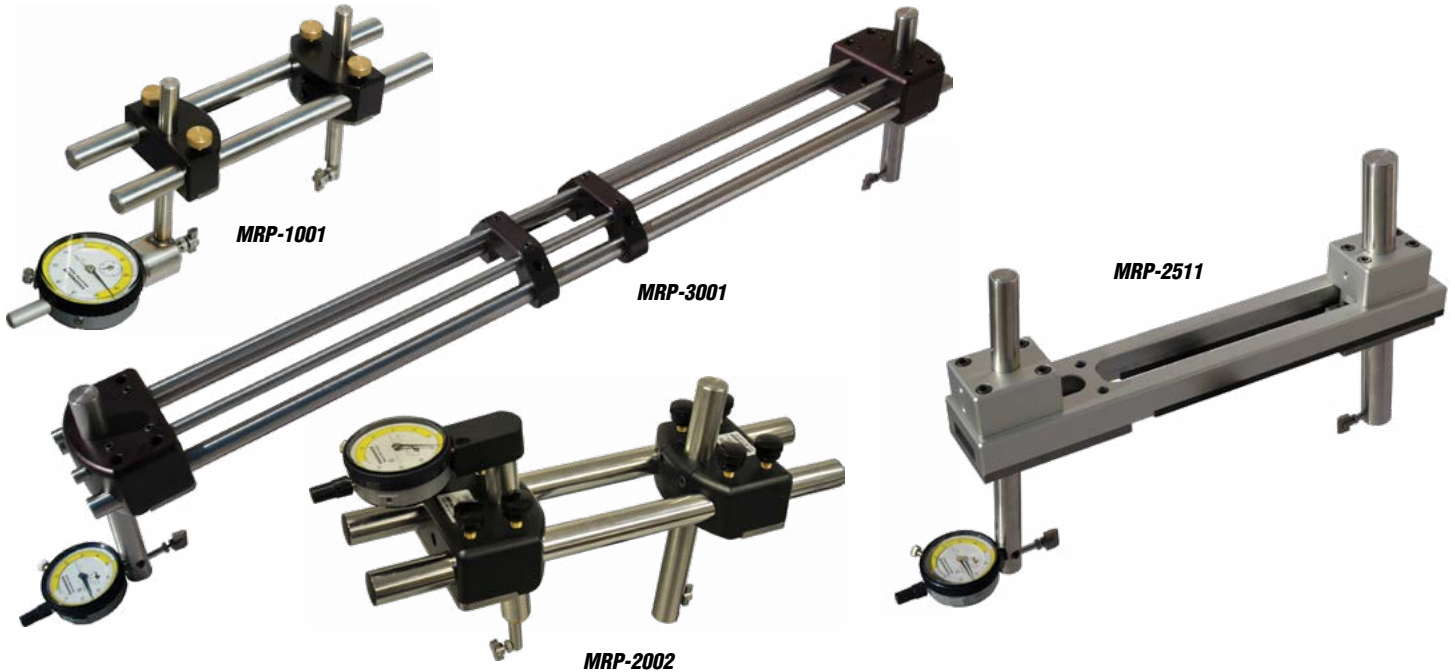

MRP® Pitch Diameter and Ovality Gages (Continued)

Model	Description	Range
MRP-2002	Internal Pitch Diameter Gage, 4¼" reach	Internal 2¾" - 20"
MRP-2002-S	Internal Pitch Diameter Gage, 4¼" reach, Straight Blocks	
MRP-2002-7	Internal Pitch Diameter Gage, 7" reach	
MRP-2002-10	Internal Pitch Diameter Gage, 10" reach	Internal 3½" - 20"
MRP-2003	Internal/External Pitch Diameter Gage, 4¼" reach	
MRP-2003-S	Internal/External Pitch Diameter Gage, 4¼" reach, Straight Blocks	2¾" - 20"
MRP-2003-7	Internal/External Pitch Diameter Gage, 7" reach	
MRP-2003-10	Internal/External Pitch Diameter Gage, 10" reach	
MRP-2511	External Pitch Diameter Gage, 4" reach	External 4½" - 9⅝"
MRP-2511-7	External Pitch Diameter Gage, 7" reach	
MRP-2512	Internal Pitch Diameter Gage, 3⅜" reach	Internal 4½" - 9⅝"
MRP-2512-7	Internal Pitch Diameter Gage, 7" reach	
MRP-2521	External Pitch Diameter Gage, 4" reach	External 4½" - 13⅜"
MRP-2522	Internal Pitch Diameter Gage, 3⅜" reach	
MRP-2513	Internal/External PD Gage, 3⅜" reach	4½" - 9⅝"
MRP-2523	Internal/External PD Gage, 3⅜" reach	4½" - 13⅜"
MRP-3001	External Pitch Diameter Gage, 3⅜" reach	External 8⅝" - 24"
MRP-3002	Internal Pitch Diameter Gage, 3⅜" reach	Internal 8⅝" - 24"
MRP-3003	Internal/External Pitch Diameter Gage, 3⅜" reach	8⅝" - 24"
MRP-3004	Internal/External Pitch Diameter Gage, 3⅜" reach	20" - 36"
MRP-3501	External Pitch Diameter Gage, w/ 6¼" reach	External 8⅝" - 24"
MRP-3502	Internal Pitch Diameter Gage, w/ 6¼" reach	Internal 8⅝" - 24"
MRP-3503	Internal/External PD Gage, w/ 6¼" reach	8⅝" - 24"

Gage parts and accessories can be found on page 105.



Shoulder Location Gages

These gages are often referred to as box depth or pin length gages. They are designed to measure the linear distance from the face to the shoulder. Some gages are comparative and preset with standards; others are direct read and need no masters. All are available with a variety of tips and contact points.

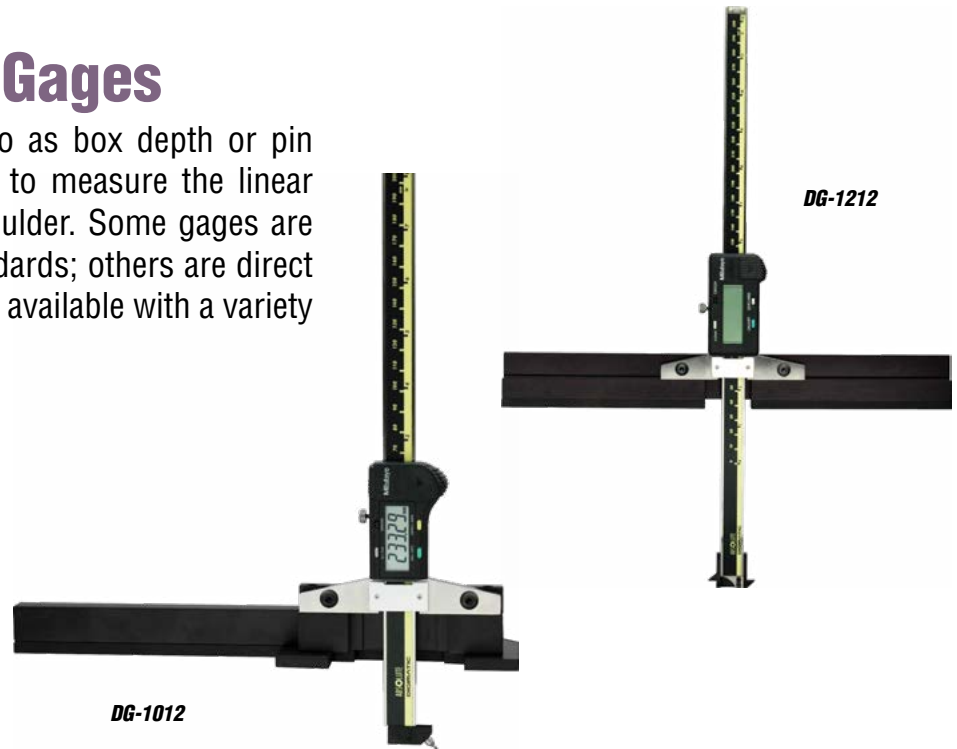

Digital Depth Gages

Our digital depth gages inspect the location of internal and external shoulders and grooves from the face of the pin and box connections or other datum surfaces. The DG-1000 Series is available with the standard base, a 12" base, and a 20" base. These gages are available in ranges: 0"-8", 0"-12", 0"-18", and 0-24".

The standard gage (DG-1000 Series) is supplied with a 7" extension arm and a 0° and 45° contact point holder for use with any #4-48 threaded contact point (one .072" contact point (T072) supplied unless otherwise requested). Longer extension arms and other contact point configurations and adapters are available upon request. The 12" (DG-1200 Series) and 20" (DG-2000 Series) gages include one double sided blade contact instead of a contact point and a contact point holder.

Digital depth gages do not require a setting standard. The gage is preset to zero on any flat surface and then applied to the product. Actual length measurements display on the gage's .0005"/.01 mm resolution digital readout. The digital readout easily converts from inches to metric and has an SPC output.

Additional gages and accessories are available, see page 148. See pages 124-125 for additional contact points.

Model	Description	Range
Depth Gage with Digital Display (in/mm)		
DG-1008	Depth Gage w/ digital display (in/mm), .0005"/.01 mm resolution	0" - 8"
DG-1012	Depth Gage w/ digital display (in/mm), .0005"/.01 mm resolution	0" - 12"
DG-1018	Depth Gage w/ digital display (in/mm), .0005"/.01 mm resolution	0" - 18"
DG-1024	Depth Gage w/ digital display (in/mm), .0005"/.01 mm resolution	0" - 24"
Depth Gage with Digital Display and 12" Base (in/mm)		
DG-1208	Depth Gage w/ digital display (in/mm), .0005"/.01 mm resolution, 12" base	0" - 8"
DG-1212	Depth Gage w/ digital display (in/mm), .0005"/.01 mm resolution, 12" base	0" - 12"
DG-1218	Depth Gage w/ digital display (in/mm), .0005"/.01 mm resolution, 12" base	0" - 18"
DG-1224	Depth Gage w/ digital display (in/mm), .0005"/.01 mm resolution, 12" base	0" - 24"



Digital Depth Gages (cont.)

Model	Description	Range
Depth Gage with Digital Display and 20" Base (in/mm)		
DG-2012	Depth Gage w/ digital display (in/mm), .0005"/.01 mm resolution, 20" base	0" - 12"
DG-2018	Depth Gage w/ digital display (in/mm), .0005"/.01 mm resolution, 20" base	0" - 18"
DG-2024	Depth Gage w/ digital display (in/mm), .0005"/.01 mm resolution, 20" base	0" - 24"

Torque Shoulder Gages and Standards

The TS-4001 Torque Shoulder Gage accurately measures the distance between the primary and secondary torque shoulders on both internal and external threaded connections. Used industry wide to measure the shoulder-to-shoulder distance on premium tool joints and the face-to-seal location on premium couplings, the Gagemaker TS-4001 is also perfectly suited to locate grooves from various datum surfaces.

The TS-4001 requires a setting standard. The gage is preset to the desired dimension and deviation is read from the gage's dial indicator.

One contact point included, please specify. One taper block is supplied according to customer taper specification. Additional taper blocks sold separately.

Model	Description	Range
TS-4001	Shoulder Depth Gage (Specify Taper)	2 3/8" & Larger
TSS-4000	TS-4001 Setting Standard	



Pipe Straightness Gages

Identifying hooked or bent pipe ends is critical when machining or swedging. These gages are direct reading and do not require setting masters. Used in a variety of applications, the most predominant use relates to threading upset end pipe.



Saddle Gage

The Saddle Gage measures the amount of hook or bend at the end of a joint of pipe. The SG-8001 uses the RC-375 roller contact. For replacements parts, please see page 147. Larger ranges available by special request only.

Model	Description	Range
SG-8001	Saddle Gage	18" Max

Squareness Gage

The SQ-1630 Squareness Gage monitors the alignment of weld-on connectors to the pipe body. Requires setting by a qualified standard. The SQ-1630S, our precision calibration square, is strongly recommended for best results. Standard sold separately.

Model	Description	Range
SQ-1636	Squareness Gage, 30" reach	up to 36" diameter
SQ-1648	Squareness Gage, 30" reach	up to 48" diameter
SQ-1630S	Squareness Gage Standard	14" X 36" Square

Straight Edge Gage

The SE-1000 Straight Edge Gage measures the straightness of well tubing and casing. The gage price includes an SES-1000 Standard. Replacement standards are available.

Model	Description	Range
SE-1000	Straight Edge	36" - 64"
SES-1000	Replacement Straight Edge Standard	



Laser Alignment Gage

The Laser Alignment Gage ensures proper angular and parallel alignment during assembly of weld-on connectors. Replacement parts are available.

Model	Description	Inside Diameter Range	Outside Diameter Range
LA-3600	Laser Alignment Gage	11" - 55"	8" - 50"



Seal Gages

Ensure the integrity of a premium connection's seal by monitoring metal-to-metal seal interference. Our seal diameter gages accurately check diameter and ovality to guarantee the quality of your product. Gages are available for internal and external seal measurements.

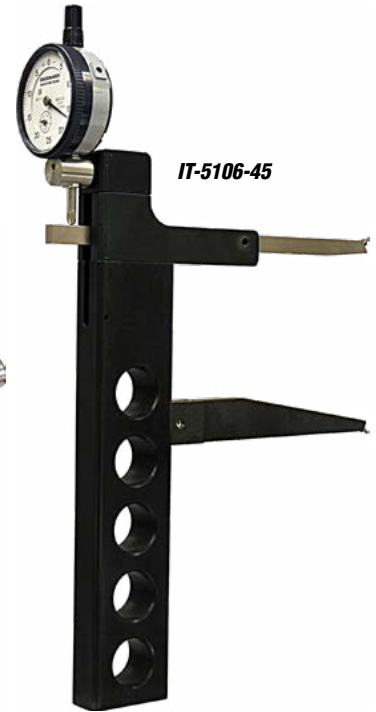
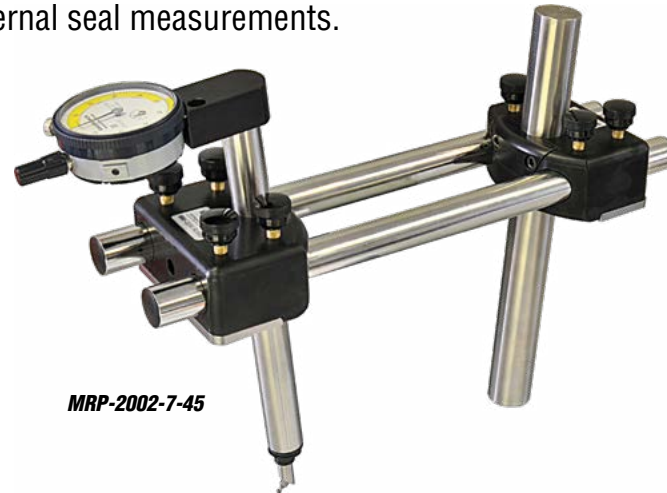

Box Seal Gage

Box Seal gages measure coupling and box seal diameters. Gage must be preset with a standard. For standards, please contact customer service for information.

Model	Description	Range
IT-5106-30	Box Seal Gage, points at 30° angle	6" Depth, 1½" - 10" Dia.
IT-5106-45	Box Seal Gage, points at 45° angle	6" Depth, 1½" - 10" Dia.

Box Seal Gage

Our MRP® style box seal gage uses contact points to inspect critical seal diameters at the back of premium connection boxes.

Model	Description	Range
MRP-2002-7-45	Back-of-Box Seal Gage, MRP® Style, 7" Depth, points at 45° angle	2¾" - 20"

PN-3000 Series Pin Seal Diameter Gages

The PN-3000 Series of gages inspect critical pin seal diameters on premium connections ranging from 2¾" - 25½". Gagemaker pin nose gages provide accurate measurements at the critical sealing point of the pin. The gage also inspects seal tapers with the addition of stand-off plates.

The PN-3000 gages use precision interchangeable contact points that position on the seal at a fixed distance from the connection face. Pin nose gage indicators have resolution of .0005". Each model covers a specific range of connection sizes, making the PN-3000 gages extremely versatile and economical. Before inspecting parts, these gages must be preset to a nominal predetermined dimension using gage blocks, MIC TRAC™, or frame standards. For additional parts and standoff plates, please see pages 144-145.

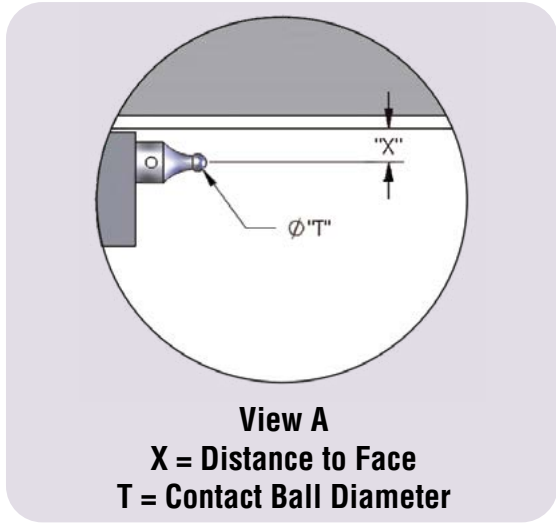

PN-3000 Series Pin Nose Diameter Gages*

The PN series measure pin nose diameter using contact points. Specify the distance from the face of the connection to the measuring plane and desired contact point diameter when ordering.

Model	Description	Range	Model	Description	Range
PN-3001	Pin Nose Diameter Gage	0" - 5½"	PN-3004	Pin Nose Diameter Gage	0" - 19½"
PN-3002	Pin Nose Diameter Gage	0" - 9½"	PN-3005	Pin Nose Diameter Gage	0" - 25½"
PN-3003	Pin Nose Diameter Gage	0" - 13½"			

*There is a separate cost to reposition the point standoff of PN-3000 Gages. Quotation available upon request.

PN-3000 Series Internal "Ball Contact" Seal Diameter Gages

The PNI series measure the internal ball contact seal diameter using contact points. Specify the distance from the face of the connection to the measuring plane and desired contact point diameter when ordering.

Model	Description	Range
PNI-3001-VMB	Internal "Ball Contact" Seal Diameter Gage	2" - 5½"
PNI-3002-VMB	Internal "Ball Contact" Seal Diameter Gage	2" - 9⅝"
PNI-3003-VMB	Internal "Ball Contact" Seal Diameter Gage	2" - 13⅝"

PN-3000 Series 30° External Apex Diameter Gages

The PNA model gages measure only the external apex diameter of the connection.

Model	Description	Range
PNA-3001-VMA	30° External Apex Diameter Gage, Anvils	2" - 4¼"
PNA-3002-VMA	30° External Apex Diameter Gage, Anvils	2" - 9⅞"
PNA-3003-VMA	30° External Apex Diameter Gage, Anvils	2" - 13⅞"

PN-3000 Series 30° Internal/External Apex Seal Diameter Gages

The PN-3000 Series 30° Internal/External Apex Seal Diameter gages measure both the internal and external diameters of the apex seal for the connection.

Model	Description	Range
PN-31VM-30	30° Internal/External Apex Seal Diameter "V"	Internal 2⅜" - 6⅞", External 4" - 6⅞"
PN-33VM-30	30° Internal/External Apex Seal Diameter "V"	Internal 2⅝" - 14", External 4" - 14"



Thread Runout Gages

Maximize efficiency of the threading process by ensuring the insert pulled out at the right time on external threads. We manufacture runout gages for both internal and external designs.

The run out gage is a three point gage having two fixed points and one movable point attached to a balanced dial indicator. Accuracy of the gage is verified by zeroing the dial indicator on a flat surface.



Buttress Runout Gage

Buttress runout gages ensure proper thread pullout on runout type threads. Thread runout is the measurement of the abruptness with which the buttress thread is terminated at the triangle end of the thread. A rapid pull-out of the cutting tool results in a steep slope at the end of the thread causing high stress when the coupling is made-up.

Buttress runout gages have standard 1" and 2" point spacing. Includes one contact point (TBR) and shoes.

Model	Description	Range
BR-2001	Buttress Runout Gage	All Sizes
BRB-2001	Buttress Runout Base Only	All Sizes
BRS-2001	Replacement Shoes (2)	

Premium Setting Standards

Premium Round Standards



Premium Frame Standards

Premium Setting Standards

We manufacture master setting standards of various styles for numerous API as well as premium connections. Setting standards duplicate critical dimensions that are then compared to the machined product. Standards can be as simple as a single diameter or length or can combine diameters, lengths, seal groove locations, tapers, sealing surfaces and thread gauging locations.

Standards are designed round as well as frame style. Setting surfaces may be cylindrical, conical, or flat and tapered. The choice of style is very much an individual's decision. All styles are manufactured to the same accuracy and precision.

All standards are put through a methodical process of rough machining, stress relieving, heat treat hardening, surface coating, and finish grinding. The result of the process produces a master size standard with accuracies where required to $\pm .00025''$.

Standards are calibrated and certified with traceability to NIST and come complete with a long form dimensional certificate.

Please Note: Premium connection standards will only be manufactured for companies with the proper permission or complete ownership of the product. Product drawings are required on the company's title block with an authorized signature. An NDA may be required to protect both parties as proprietary information is often involved.



MUD MOTOR POWER SECTION





**MUD MOTOR
POWER
SECTION GAGES**



MUD MOTOR POWER SECTION

Maximize the Performance of Your Power Section

Drilling faster without stalls is critical to any drilling operation. The demands placed on the drilling motor to achieve optimum performance require the proper fit between the rotor and the stator in the power section. Gagemaker's Power Section Gages ensure this fit meets these specifications.

With Gagemaker's Stator Bore Diameter Gages, Rotor Major Diameter Gages, and Rotor Minor Diameter Gages, you are armed to maintain the quality of the power section you produce. With this arsenal of inspection gages, there's not a motor or pump out there that can't be inspected.





Stator Bore Diameter Measurement



Rotor Major and Minor Diameter Measurement



Stator Bore Diameter Measurement



Each of Gagemaker's electronic Stator Bore Gages provides data collection and data storage options of bore measurements. The gage is supplied with your choice of a light duty netbook or a heavy duty notebook computer. Both provide the ability to enter a serial number and store inspection data as a file for future reference. The data can also be ported through a wireless link to a central computer for further processing.

Durable, accurate, easy to use, the Gagemaker Stator Bore Gages ensure your quality levels remains at the highest level possible.

Electronic Stator Minor Bore Gages

The SBG series of gages determines a precise stator/rotor match by measuring the largest and smallest bore diameters. Attaching or removing different height extension shoes achieves the gage's range flexibility. Both gage models address any pitch or lobe configuration.

The SBG-5000E measures diameters from 1.500" - 2.000". Additional shoes are available for inspecting diameters larger than 2.000" and up to 7.500" (see page 75).

The SBG-5000E includes three extension shoes, a interface box, a computer, measurement software, cables, and setting standard base (standard not included).

Setting standards are sold separately, please see page 74.

Model	Description	Range
SBG-5000E	Electronic Stator Bore Gage with interface box, computer, software, standard base, & SB-2100, SB-2110, SB-2120 extension shoes	1.500" - 2.000"

Indicator Style Stator Minor Bore Gage

Gagemaker also offers two indicator based versions of the electronic SBG-5000 model. One setting standard assembly without setting standard and three shoes are included. For diameters over 2.000", additional shoes are required. Please see page 75 for more shoes. Setting standards are sold separately, please see page 74.

Model	Description	Range
SBG-5000A	Stator Bore Gage with Analog Indicator and SB-2100, SB-2110, and SB-2120 extension shoes	1.500" - 2.000"
SBG-5000D	Stator Bore Gage with Digital Indicator and SB-2100, SB-2110, and SB-2120 extension shoes	1.500" - 2.000"



Interface Box & Computer

Connection Cable



SBG-5000E

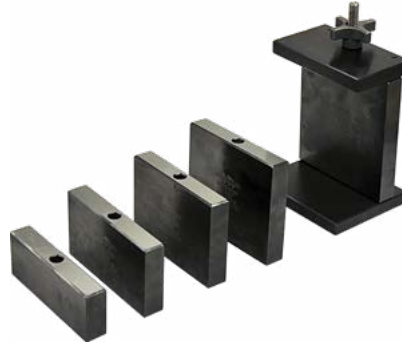

SBG Flat Standards

Gagemaker Stator Bore

File Device Settings Help

Real-Time Measurement

2.3750

To Table

GAGEMAKER

	Value	Deviation
1	2.3750	0.0000
2	2.3748	-0.0002
3	2.3659	-0.0091
4	2.3666	-0.0084
5	2.3530	-0.0220
6	2.3624	-0.0126
7	2.3516	-0.0234
8	2.3606	-0.0144
9	2.3522	-0.0228

Stator Serial #: _____

Standard Size: 2.375

Current Standard Size: 2.375 Average: 2.3609

Scanner: Max Value 0.0000 Display Units: Inches

Min Value 0.0000 Millimeters

Save as CS

Enabling Form





Setting Standard Assembly

All Stator Bore Gages require presetting prior to part inspection. The flat style standard provides an economical method to accurately preset the gage. For smaller diameters, round standards are preferable and are also available.

The assembly allows for fast and secure setup. The flat style standards use a common base and top plate and use interchangeable flat sizing blocks to achieve the setting distance required. A speed nut locks the assembly together quickly and securely.

Setting standards do not need to be sized to the exact bore of the stator's bore. As long as the size of the standard is within the measurement range of the gage, it can be used to preset the gage.

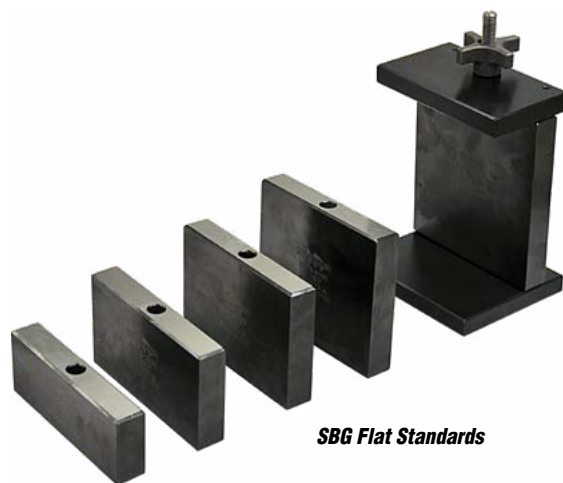

SBG Flat Standards

SBG-5000A, SBG-5000D, and SBG-5000E Flat Standards

Setting Master Height	Flat Standard Model	Setting Master Height	Flat Standard Model
1.600"	SBFS-1600	4.640"	SBFS-4640
1.727"	SBFS-1727	4.750"	SBFS-4750
1.800"	SBFS-1800	4.900"	SBFS-4900
2.062"	SBFS-2062	5.060"	SBFS-5060
2.187	SBFS-2187	5.150"	SBFS-5150
2.375"	SBFS-2375	5.240"	SBFS-5240
2.598"	SBFS-2598	5.350"	SBFS-5350
2.700"	SBFS-2700	5.420"	SBFS-5420
2.736"	SBFS-2736	5.500"	SBFS-5500
2.900"	SBFS-2900	5.600"	SBFS-5600
3.080"	SBFS-3080	5.750"	SBFS-5750
3.150"	SBFS-3150	5.850"	SBFS-5850
3.245"	SBFS-3245	5.960"	SBFS-5960
3.303"	SBFS-3303	6.050"	SBFS-6050
3.400"	SBFS-3400	6.140"	SBFS-6140
3.425"	SBFS-3425	6.250"	SBFS-6250
3.500"	SBFS-3500	6.375"	SBFS-6375
3.625"	SBFS-3625	6.500"	SBFS-6500
3.750"	SBFS-3750	6.600"	SBFS-6600
3.976	SBFS-3976	6.750"	SBFS-6750
4.000"	SBFS-4000	6.860"	SBFS-6860
4.160"	SBFS-4160	6.950"	SBFS-6950
4.250"	SBFS-4250	7.040"	SBFS-7040
4.370"	SBFS-4370	7.220"	SBFS-7220
4.520"	SBFS-4520	7.375"	SBFS-7375
4.567"	SBFS-4567	7.450"	SBFS-7450

Custom Sizes and Round Standards (usually for smaller diameters) are available as special requests.

Stator Bore Extension Shoes

Stator bore gage extension shoes provide flexibility to the gauging package by simple changing a shoe or adjusting a shoe when stator diameters change. Extension shoes are lightweight metal that are anodized to resist wear.

The style of extension shoe depends on the diameter range being measured. Shoes are offered in several lengths depending on the pitch of the stator lobes. It is important that the shoe length be long enough to contact a minimum of two points on the bottom and one point on the top pad.



SBG-5000A, SBG-5000D, and SBG-5000E Extension Shoes

Extension shoes are designed with flexibility in mind. The wide range of bores is balanced with the travel of the gage to provide just the right fit for your stator. Select the shoe that best meets the minor diameter range of the stator to be inspected.

Model	Description	Range
SB-2100	8" long extension shoe	1.500" – 1.650"
SB-2110	8" long extension shoe	1.650" – 1.800"
SB-2120	8" long extension shoe	1.800" – 1.950"
SB-2200	20" extension shoe (requires riser, see below)	
SB-2150	.130" riser – SB-2200 extension shoe required	2.000" – 2.150"
SB-2300	.280" riser – SB-2200 extension shoe required	2.150" – 2.300"
SB-2400	.380" riser – SB-2200 extension shoe required	2.250" – 2.400"
SB-2500	.480" riser – SB-2200 extension shoe required	2.350" – 2.550"
SB-2600	.580" riser – SB-2200 extension shoe required	2.450" – 2.600"
SB-3500	20" extension shoe w/ brackets and adapter	2.600" – 3.500"
SB-4500	20" extension shoe w/ brackets and adapter	3.450" – 4.500"
SB-5500	20" extension shoe w/ brackets and adapter	4.450" – 5.500"
SB-6500	20" extension shoe w/ brackets and adapter	5.450" – 6.500"
SB-7500	20" extension shoe w/ brackets and adapter	6.450" – 7.500"



Rotor Major & Minor Diameter

Today in the oil field industry, unique high-performance power sections require accurate measurement tools for rotors and stators. Gagemaker has designed several gages to measure a rotor's major and minor diameters. The Gagemaker Major Diameter T-Micrometer (T-MIC) is for rotor major diameters (0" - 9") and comes with bases ranging from 6" to 24". Gagemaker's Minor Diameter Gage (MM) is for inspecting rotor minor diameters (0" - 6").

- The T-MIC's frame is not only the strongest and most rigid available on the market today, but the hardened and ground A-2 tool steel base rails are re-grindable after years of service
- The T-MIC's micrometer thimble mount allows for calibration and replacement
- The T-MIC's micrometer thimble is available with a flat or radiused micrometer stem
- Both the T-MIC and MM are durably constructed for the harshest work environments



Rotor Minor Diameter (MM)

Gagemaker's Minor Diameter gage was designed to measure a rotor's minor diameter. The spiral lobes on the rotor produce a valley, or minor diameter. The depth of the minor diameter from the major diameter requires a 1" travel indicator stem. The range of the gage (0" - 6") allows measuring most rotor sizes with only one gage. Ensuring the gage's durability and long life, Gagemaker's design uses a heavy duty indicator stem and bearing housing to withstand side loads. Special sizes are available.

Model	Description	Diameter Range
MM-0-6	Minor diameter micrometer	0" - 6"

Rotor Major Diameter Micrometer (T-MIC)

Due to high spirals on the lobes, conventional measurement gages cannot be used for measuring rotor major diameters. Gagemaker developed the T-MIC to measure a rotor's major diameter. The T-MIC's base spans across two lobes on one side of the centerline and uses a micrometer thimble on the other to measure the diameter. Instead of modifying an existing micrometer, Gagemaker custom builds each T-MIC. Gagemaker's rugged design far exceeds all others on the market today. Special sizes are available, contact customer service for more information. **Special sizes, metric thimbles, and metric sizes are available.**

Range	Model					Description
	6" Base	8" Base	12" Base	18" Base	24" Base	
0" - 1"	TM6-0-1	TM8-0-1	TM12-0-1	TM18-0-1	TM24-0-1	T-MIC for Rotor, ½" wide base
1" - 2"	TM6-1-2	TM8-1-2	TM12-1-2	TM18-1-2	TM24-1-2	
2" - 3"	TM6-2-3	TM8-2-3	TM12-2-3	TM18-2-3	TM24-2-3	
3" - 4"	TM6-3-4	TM8-3-4	TM12-3-4	TM18-3-4	TM24-3-4	
4" - 5"	TM6-4-5	TM8-4-5	TM12-4-5	TM18-4-5	TM24-4-5	
5" - 6"	TM6-5-6	TM8-5-6	TM12-5-6	TM18-5-6	TM24-5-6	
6" - 7"	TM6-6-7	TM8-6-7	TM12-6-7	TM18-6-7	TM24-6-7	
7" - 8"	TM6-7-8	TM8-7-8	TM12-7-8	TM18-7-8	TM24-7-8	
8" - 9"	TM6-8-9	TM8-8-9	TM12-8-9	TM18-8-9	TM24-8-9	



Rotor Major Diameter T-Micrometer with Digital Micrometer

Gagemaker also offers our T-MICs with digital micrometers. The digital micrometer can transfer your data to a computer via the included SPC output. **Special sizes, metric thimbles, and metric sizes are available.**

Range	Model					Description
	6" Base	8" Base	12" Base	18" Base	24" Base	
0" - 1"	TM6-0-1-352	TM8-0-1-352	TM12-0-1-352	TM18-0-1-352	TM24-0-1-352	T-MIC for Rotor, 1/2" wide base with a Mitutoyo 350-352-10 digital micrometer and SPC output
1" - 2"	TM6-1-2-352	TM8-1-2-352	TM12-1-2-352	TM18-1-2-352	TM24-1-2-352	
2" - 3"	TM6-2-3-352	TM8-2-3-352	TM12-2-3-352	TM18-2-3-352	TM24-2-3-352	
3" - 4"	TM6-3-4-352	TM8-3-4-352	TM12-3-4-352	TM18-3-4-352	TM24-3-4-352	
4" - 5"	TM6-4-5-352	TM8-4-5-352	TM12-4-5-352	TM18-4-5-352	TM24-4-5-352	
5" - 6"	TM6-5-6-352	TM8-5-6-352	TM12-5-6-352	TM18-5-6-352	TM24-5-6-352	
6" - 7"	TM6-6-7-352	TM8-6-7-352	TM12-6-7-352	TM18-6-7-352	TM24-6-7-352	
7" - 8"	TM6-7-8-352	TM8-7-8-352	TM12-7-8-352	TM18-7-8-352	TM24-7-8-352	
8" - 9"	TM6-8-9-352	TM8-8-9-352	TM12-8-9-352	TM18-8-9-352	TM24-8-9-352	



Custom Gages

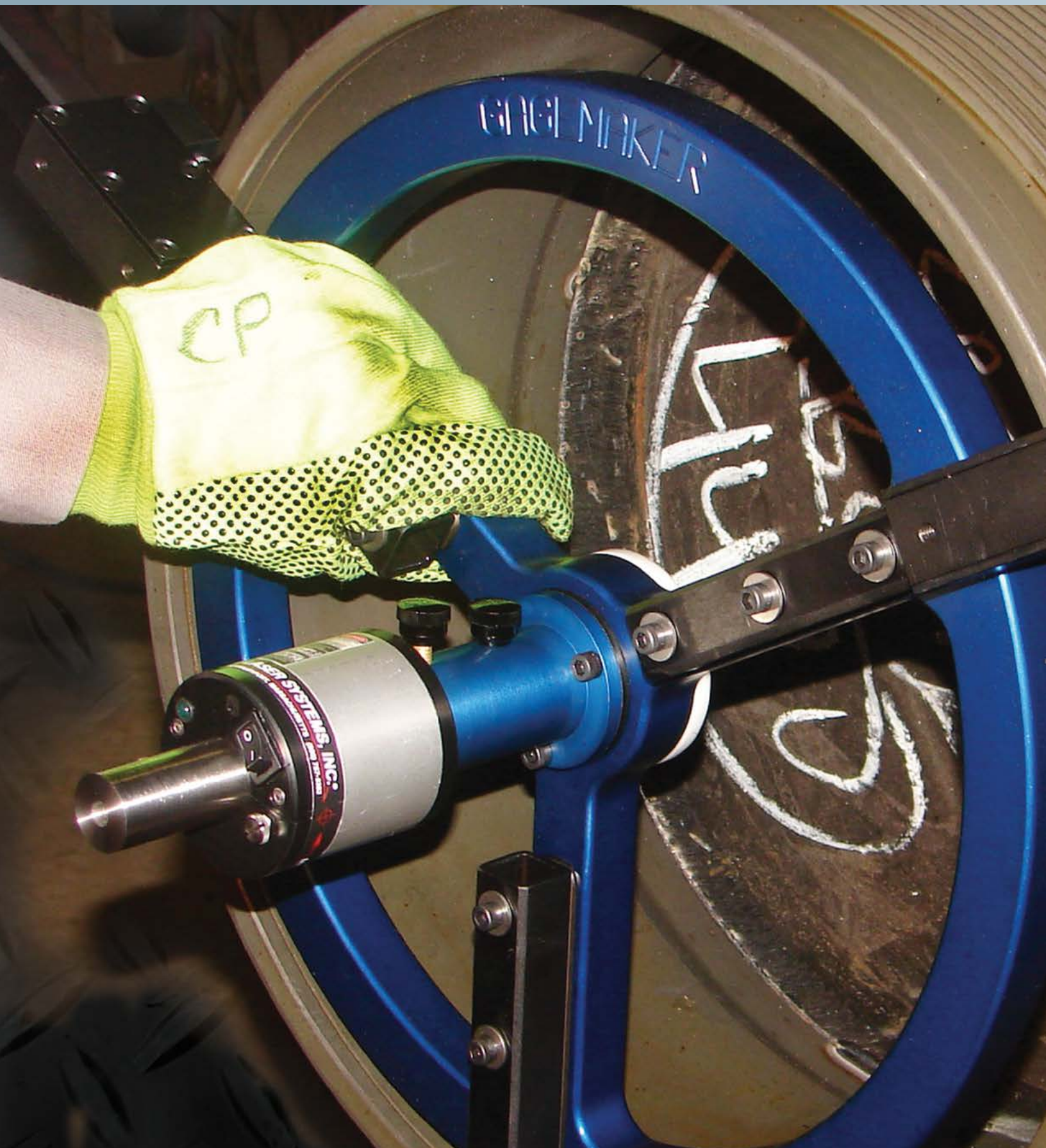



CUSTOM GAGES



The Gages You Need, When You Need Them

For 25 years we have been solving gauging problems by offering custom gage designs. Customers from all industries contact our design team for help with inspecting the impossible. We will find a solution for your most intricate designs.

Using the most modern and up to date manufacturing equipment, our machinists turn unique designs into reality by sculpting gages that meet the most demanding requirements.

We have designed and built several hundred special gages over the years. Let us introduce you to some of the many products our design team has produced.



CONFIDENTIALITY STATEMENT

Gagemaker maintains confidentiality of all proprietary connection designs through signed agreements. Gagemaker will not provide any quotations nor ship any gages or setting standards to any unauthorized party. Customers doing work for companies that require proprietary gages will be required to submit approval in writing prior to receiving any quotes or gages.



Measurement & Calibration





MEASUREMENT & CALIBRATION SYSTEMS





Measurement & Calibration

MIC TRAC™ 4000 In-House Precision Gage Calibration System

Inspect Parts, Calibrate, and Track Gages



Choosing the Right

Step 1: Find what type of gages you have.

Gages & Indicators for Calibration	RG-7000	PD-8000	Calipers	Depth Micrometers	Indicators	LG-5002 / Allen Lead Gage	LG-5003

Step 2: Determine which system you need.

MT-4000 (Accuracies to .0001" (.254μ))	<input checked="" type="checkbox"/>	<input checked="" type="checkbox"/>	<input checked="" type="checkbox"/>	<input checked="" type="checkbox"/>	<input checked="" type="checkbox"/>	<input checked="" type="checkbox"/>	<input checked="" type="checkbox"/>
MT-3000 (Accuracies to .0002" (.508μ))	<input checked="" type="checkbox"/>	<input checked="" type="checkbox"/>	<input checked="" type="checkbox"/>	<input checked="" type="checkbox"/>	<input checked="" type="checkbox"/>	<input checked="" type="checkbox"/>	<input checked="" type="checkbox"/>

Step 3: Locate the fixtures and accessories necessary.

Necessary Fixtures & Accessories By Gage Type	Cal-Pak Calibration Package <small>Included with MT-4000 In-House Calibration System; can be purchased separately.</small>						
	TF-1F	TF-SA	TF-CA	TF-DG	TF-IND	TF-LG-2	TF-LG-3
TF-SA to Support RG-7000/PG-6000 for Setting 	 	TF-SA to Support Long Calipers 	 				



MIC TRAC™ 3000 Shop Floor Gage Setting and Part Measurement System

Measure Parts, Calibrate Hand-Held Gages, and Preset Indicator Style Gages

Calibration System

TH-3000 	PD-8000 	Test Indicator 	Cylindrical Ring 	Threaded Plug 	Threaded Ring (Solid Only) 	Cylindrical Plug (NPT) 	Spline Gage 	Dial Bore Gage
--------------------	--------------------	---------------------------	-----------------------------	--------------------------	---------------------------------------	-----------------------------------	------------------------	---------------------------



(≥0.0001" Res.)



(≥0.0005" Res.)

Additional Calibration Accessories

These fixtures and accessories are not part of the CAL-PAK and must be purchased separately.

TF-VB 	TF-SV 	TF-SS <i>(included in the CAL-PAK)</i> 	TF-CR 	TF-2R 	TF-IT 	TF-TP 	TF-SP 	TF-VN
TF-1F 	TF-1F 	TF-1F <i>(included in the CAL-PAK)</i> <p>TF-TI Required with TF-SS to Test Indicator Probes TF-TI</p>	<p>1-2-3 BLOCKS</p> <p>INTERNAL GAGE BLOCK</p>	<p>MASTER RING GAGE BLOCK TF-WH</p>	<p>1-2-3 BLOCKS</p>	<p>TF-2R THREAD WIRES</p>	<p>1-2-3 BLOCKS</p>	<p>TF-1F <i>(included in the CAL-PAK)</i></p>



Choosing the Right Calibration System

Most companies use various gages and tools that need calibrating, setting, and zeroing. Historically, calibration caused multiple headaches from tracking, scheduling, shipping, and instrument downtime. Now, companies who implement in-house calibration see a quick return on their investment with less headaches and increased efficiency. Gagemaker systems are customizable, allowing you to create your own calibration plan as simple or as comprehensive as you want. Our versatile, cost effective and easy-to-use **MIC TRAC™** calibration and gage setting systems produce accurate, repeatable, reproducible results that you can trust.





**MIC TRAC™ 3000
Shop Floor Gage Setting and
Part Measurement System**



**MIC TRAC™ 4000 In-House Precision
Gage Calibration System**

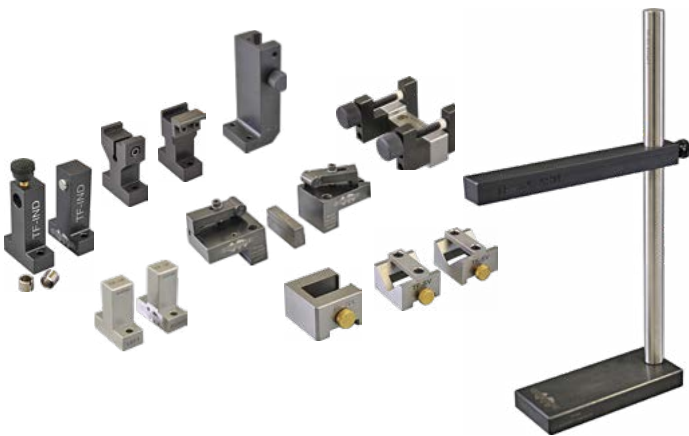

Calibration Accessories



Calibrator Gage



Shop Floor Gage Setting and Part Measurement System

Employing a versatile bench mounted length measuring system allows you to calibrate hand-held gages, preset indicator style gages, and with the optional Force-Lok, measure parts. The MIC TRAC™ 3000 Shop Floor Series Gage Setting And Part Measurement System sets or zeros most gages with the standard resolution of .00005", accuracies ranging from ±.0001" to ±.0004" (traceable to the NIST) and the digital read out is CE approved. The cost effective Force-Lok feature improves repeatability from operator to operator and is well suited for a variety of environments including the shop floor.



MIC TRAC™ 3000 Shop Floor Gage Setting and Part Measurement System

MT-3000 Standard Base Units Without Force-Lok. Supplied with Digital Readout, TF-PL setting blocks, and shipping carton.

Model	Description	Accuracy	Resolution	Internal Range	External Range
MT-3012-50	MIC TRAC™ Base Unit w/ DRO	±.0001"	.00005"	0" – 12"	1½" - 13½"
MT-3024-50	MIC TRAC™ Base Unit w/ DRO	±.0002"	.00005"	0" – 24"	1½" - 25½"
MT-3036-50	MIC TRAC™ Base Unit w/ DRO	±.0003"	.00005"	0" – 36"	1½" - 37½"
MT-3048-50	MIC TRAC™ Base Unit w/ DRO	±.0004"	.00005"	0" – 48"	1½" - 49½"
MT-3060-50	MIC TRAC™ Base Unit w/ DRO	±.0005"	.00005"	0" – 60"	1½" - 61½"

MT-3000 Standard Base Units With Force-Lok. Supplied with Digital Readout, TF-PL setting blocks, and shipping carton.

Model	Description	Accuracy	Resolution	Internal Range	External Range
MT-3012F-50	MIC TRAC™ Base Unit w/ DRO	±.0001"	.00005"	0" – 12"	1½" - 13½"
MT-3024F-50	MIC TRAC™ Base Unit w/ DRO	±.0002"	.00005"	0" – 24"	1½" - 25½"
MT-3036F-50	MIC TRAC™ Base Unit w/ DRO	±.0003"	.00005"	0" – 36"	1½" - 37½"
MT-3048F-50	MIC TRAC™ Base Unit w/ DRO	±.0004"	.00005"	0" – 48"	1½" - 49½"
MT-3060F-50	MIC TRAC™ Base Unit w/ DRO	±.0005"	.00005"	0" – 60"	1½" - 61½"

A computer can be added for additional cost to any of the above MT-3000 models. Setting Blocks are also available. Please see pages 132 -133 for more options.

Gage Setting, Part Measurement, & Hand Tool Calibration System

Gagemaker offers the MT-3000 system with data capture and document storage options. This system includes a computer connected to the MIC TRAC™ and the CERTIFI™ software for producing calibration documents. The base unit ships with the Force-Lok feature that allows for calibration of micrometer and rod standards.



MIC TRAC™ 3000 Gage Setting, Part Measurement, and Hand Tool Calibration System

MT-3000 Base Units With Force-Lok, Computer, MT-4-USB, TF-PL setting blocks, and a shipping carton.

Model	Description	Accuracy	Resolution	Internal Range	External Range
MT-3012F-50-USBC	MIC TRAC™ Base Unit with Force-Lok, Computer, & MT-4-USB	±.0001"	.00005"	0" – 12"	1½" - 13½"
MT-3024F-50-USBC	MIC TRAC™ Base Unit with Force-Lok, Computer, & MT-4-USB	±.0002"	.00005"	0" – 24"	1½" - 25½"
MT-3036F-50-USBC	MIC TRAC™ Base Unit with Force-Lok, Computer, & MT-4-USB	±.0003"	.00005"	0" – 36"	1½" - 37½"
MT-3048F-50-USBC	MIC TRAC™ Base Unit with Force-Lok, Computer, & MT-4-USB	±.0004"	.00005"	0" – 48"	1½" - 49½"
MT-3060F-50-USBC	MIC TRAC™ Base Unit with Force-Lok, Computer, & MT-4-USB	±.0005"	.00005"	0" – 60"	1½" - 61½"

*Even higher resolution MT-3000 systems are also available.
Setting Blocks can be found on page 133.*



MIC TRAC™ 4000 In-House Precision Gage Calibration System

Establishing an in-house calibration service represents an investment in facilities, equipment and trained personnel, but grants you total control over all of your calibration process as well as saves you time and money over the long term. Gagemaker's MIC TRAC™ 4000 Series In-House Precision Gage Calibration System enables you to inspect parts, calibrate and track a wide variety of gage styles including solid ring and plugs. This innovative high precision metrology system with 1.00" travel guarantees extremely high accuracies to ± 0.00002 and a resolution of $.00001$ " (traceable to the NIST). This system also enables you to track and maintain gage history as well as produce calibration certificates.



MIC TRAC™ 4000 In-House Precision Gage Calibration System

This package features the MIC TRAC™/MT-4000 as a precision calibration system. The system accepts fixtures that inspect and calibrate a wide range of gage diameters and thread pitches. The package includes all the equipment necessary to calibrate precision handheld gages. **Solid ring and plug inspection requires the purchase of additional accessories.**

Package includes:

- MT-4012-10 MIC TRAC™ electronic adjustable measurement master, range 0" to 12". Base unit is error compensated to an accuracy of ± 0.00005 ", resolution $.00001$ ", travel 12.000".
- Ultra precision scale with 1.00" travel, accuracy ± 0.00002 ", and resolution $.00001$ ".
- Computer with CERTIFI™ Calibration Software. CERTIFI™ produces calibration reports, has a recall database, and a digital readout acquisition module. (MT-4-USB)
- CRC MT-4000 Calibration Reference card set-up procedures documenting calibrations with the Gagemaker system
- TF-2R: Carbide anvil set, $\frac{3}{8}$ " diameter
- TF-XYT: Adjustable X, Y & tilt support table for use with the MIC TRAC™
- CAL-PAK: Assortment of fixtures designed to hold gages for calibration
- TDWIN Thread Disk™ software program: provides critical thread dimensions for manufacturing and inspection of UN, Acme, Stub Acme, Metric, Buttress, and NPT threads.
- Torque wrench, 50 in. lb. (TW-50)
- AWH-100 bench-top tool holder with wrenches
- Reusable shipping container

Model	Description	Range
PGC-12-W2	Precision Calibration Package	0" - 12"
PGC-24-W2	Precision Calibration Package with MT-4024-10 MIC TRAC™	0" - 24"
PGC-36-W2	Precision Calibration Package with MT-4036-10 MIC TRAC™	0" - 36"
PGC-48-W2	Precision Calibration Package with MT-4048-10 MIC TRAC™	0" - 48"



System Accessories

Gagemaker provides multiple fixtures and accessories that enable you to calibrate many types of hand-held gages using the MIC TRAC™ System. Precision fixtures are designed to ensure the gage's proper positioning which is vital in securing the highest calibration accuracy and most consistent measurement results.

The CAL-PAK collection of fixtures handles most standard Gagemaker gages, as well as calipers, dial indicators, test indicators, bore gages, micrometers, micrometer standards and depth gages (See pages 84-85 for calibration guide.) The CAL-PAK can be used on both the MT-3000 and MT-4000, while other fixtures and accessories are only applicable to the MT-3000. This huge variety of accessories provides unmatched versatility in measurement capabilities.

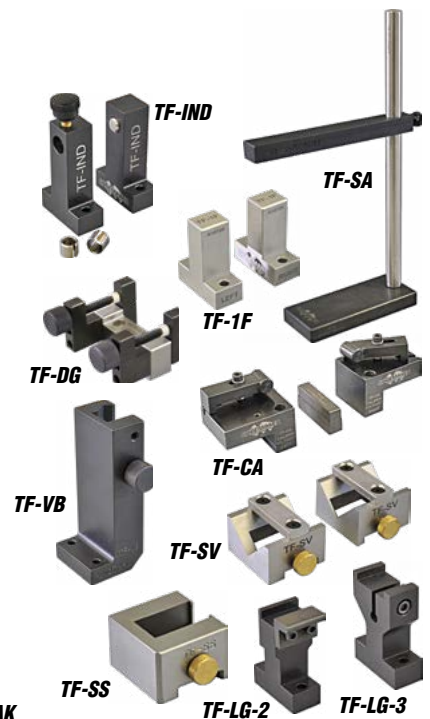

MIC TRAC™ System Options

The following base units and accessories are available for additional requirements for either the MIC TRAC™ 3000 or MIC TRAC™ 4000.

Model	Description
CAL-PAK	Complete Calibration Package (All fixtures are also individually available.) Includes: TF-1F, TF-CA, TF-DG, TF-IND, TF-LG-2, TF-LG-3, TF-SA, TF-SS, TF-SV, TF-VB, and storage case
TF-TI	Test indicator calibration block*
TF-VN	"V" blocks for calibration of axial travel probes and bore gages
TF-BA	Base support block for setting dial bore gages**
TF-BI	Base support plate for setting dial bore gages**
TF-CG	Universal clamping fixture for calibration of indicators and gages*

*One TF-1F block required with this accessory, sold separately; **Two TF-1F blocks required with this accessory, sold separately

MIC TRAC™ 3000 Calibration Documentation

Model	Description
CRC-MT3000	Complete procedural documentation for the calibration of handheld inspection equipment including: O.D. & I.D. micrometers, calipers, depth micrometers, and more.

MIC TRAC™ 4000 Only Accessories

Model	Description
CRC-MT4000	Complete procedural documentation for the calibration of handheld inspection equipment including: O.D. & I.D. micrometers, calipers, depth micrometers, ring and plug gages, and more.
MT-4-USB	Digital readout software module with digital data acquisition card w/ CERTIFI™
TF-2R	3/8" diameter carbide anvil set
TF-SB	Adjustable height support table
TF-SB-1	Bearing rail support base
TF-XYT	Adjustable height support table, X-axis & Y-axis support base

Bench Calibrator

The Gagemaker calibrator gage, CG-1001/CG-1001E, calibrates gages and indicators per AGD specification. The CG-1001 uses a non-rotating spindle screw type micrometer which reads directly to .0001" and can be estimated to the closest .00005".

Disassembling the gage is not required for calibration. The vise assembly allows full vertical and horizontal adjustment of the gage or indicator clamped in the vise jaws. During calibration, an outboard arm and arm support allows for larger gage assemblies to be securely supported.

Four supplied accessory fixtures will help speed up calibration while maintaining accuracy.



CG-1001

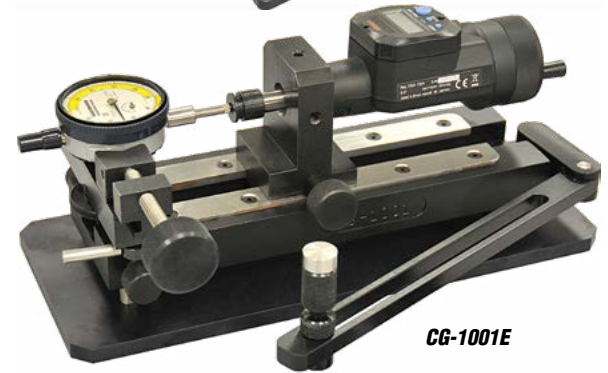

CG-1001E

Bench Calibrator

The CG-1001 is our standard bench calibrator, while the CG-1001E is our digital version which includes an SPC output. The CG-1000 models are shipped in a durable custom shipping/storage case. Optional wooden storage cases available.

Model	Description	Range	Accuracy
CG-1001	Bench Calibrator	.0001" Resolution, Mechanical	±.0001
CG-1001E	Digital Bench Calibrator w/ SPC Output	.00005"/.001 mm Resolution, Digital	±.00015

Bench Calibrator Fixtures

Bench Calibrator fixtures are included with the purchase of any bench calibrator, but are also offered individually as additional or replacements. These fixtures are used in calibration of select gages. Not all applicable gages require a fixture; however, some gages require two fixtures.

Model	Description	Applicable Gages
CG-1001-A	Bench Calibrator Fixture A	Lead Gages, Internal Taper Gage (IT-6000)
CG-1001-B	Bench Calibrator Fixture B	Lead Gages, Internal Taper Gage (IT-6000)
CG-1001-C	Bench Calibrator Fixture C	MRP® Series, Internal Thread Height (TH-3000 INT)
CG-1001-D	Bench Calibrator Fixture D	Indicators

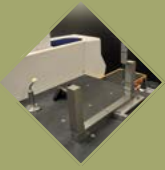

Calibration Services & Repair

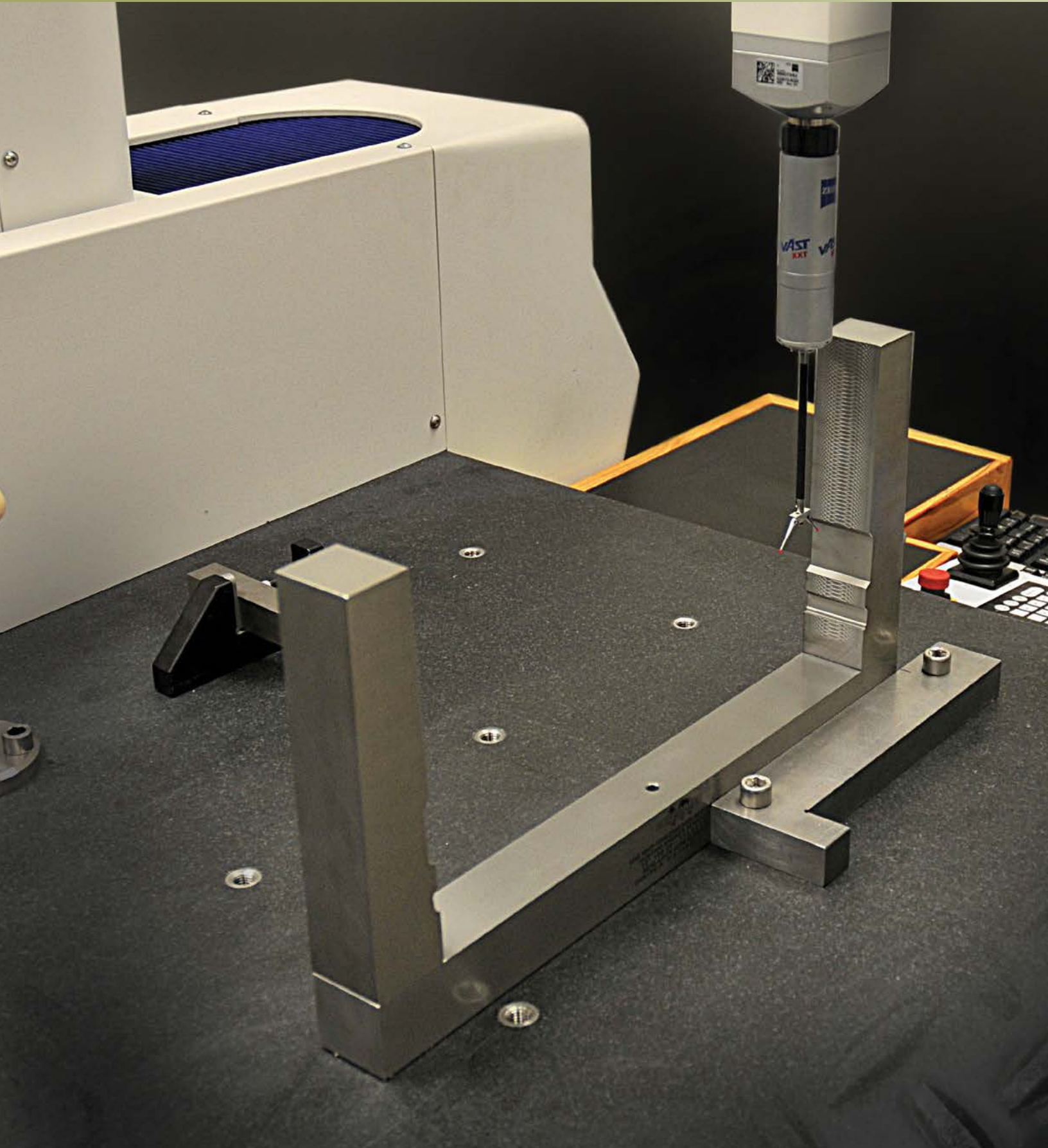



**CALIBRATION
SERVICES &
REPAIR**

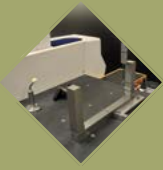

Calibration Services & Repair

Calibration Services & Repair

As an OEM and ISO/IEC 17025:2005 certified, we offer professional calibration services for all the gages that we manufacture. Our repair facility is fully equipped to service your gages and get them back to their original condition. We maintain a complete inventory of replacement parts so we can provide a quick turnaround to keep your operation running smoothly.

Gagemaker provides full service calibration, parts and repair on all MIC TRACS sold. At no extra charge, a standard long form certificate is provided with all calibrations of MIC TRAC™ units. Calibration maintenance often necessitates repair work. All repairs are quoted and require customer authorization prior to work being done.





MIC TRAC™ Calibration Pricing



Calibration Services and Repair Rates

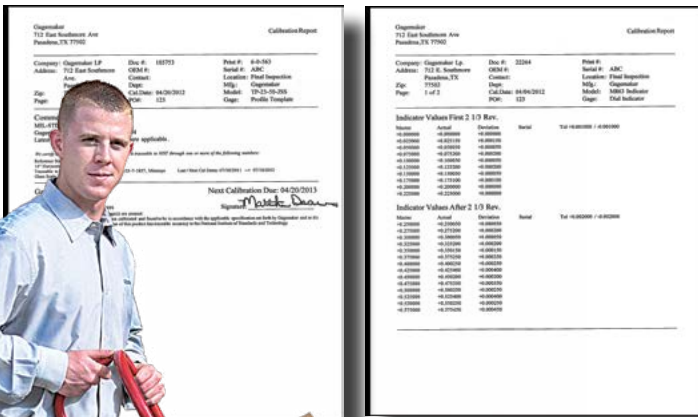

Calibration Certificates

Shipping & Care

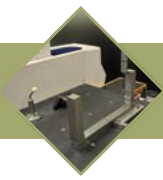

MIC TRAC™ Calibration Pricing

Gagemaker provides full service calibration and repair on all MIC TRACS sold. At no extra charge, a standard long form certificate is provided with all calibrations of MIC TRAC™ units.

Calibration maintenance may require repair work. All repairs are quoted and require customer authorization prior to work being done.

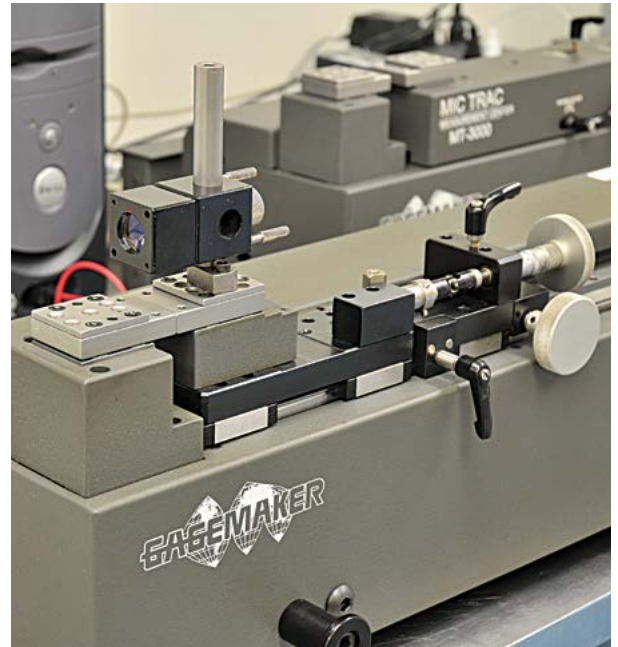

MIC TRAC™ Calibration and Repair

MIC TRAC™ Model	MIC TRAC™ Model Options			Repair Rate (\$USD/hr)
	MIC TRAC™ Non Force-Lok Unit	MIC TRAC™ Force-Lok Unit	MIC TRAC™ with SLEC File	
MT-3012	Contact Us	Contact Us	Contact Us	Contact Us
MT-3024				
MT-3036				
MT-3048				
MT-3060				
MT-4012			Contact Us	
MT-4024				
MT-4036				
MT-4048				

All figures are in US Dollars.

Note 1: Gagemaker cannot guarantee the accuracy of a MIC TRAC™ unit, unless it is correctly packaged and shipped in a proper container. Prior to shipping, please request a Return Authorization Number and instructions. Current cost for a standard MIC TRAC™ 3000 Series replacement shipping container is \$525.00*(See Note 3). For all other containers, please call for a quotation. At no additional charge, all MIC TRAC™ units are supplied with a calibration certificate and inch-by-inch error report.

Note 2: MT-2000 Series units are considered obsolete. We will calibrate MT-2000 Series unit, but we will not make any adjustments to improve the accuracy. Call for pricing.

Note 3: Prices subject to change without notice.

Calibration Services and Repair Rates

Gagemaker offers calibration and repair services for many of its products. Non-Gagemaker manufactured gages are quoted on an individual basis. Please consult the table below for basic information on our services.

For additional information on calibration and repair please contact our customer service department.



Gages, Standards, and Inspection Equipment Calibration and Repair

Model	Services Available	Calibration Price (\$USD)*	Repair Rate (\$USD/hr)*
Gage Calibration Equipment			
TF-1F, TF-2R Setting Blocks	Inspect flatness, parallelism, and size	Contact Us	Contact Us
TF-__T Taper Blocks	Inspect taper and size		
TF-__RSC Taper Block Set	Inspect taper and size		
TF-BX Setting Blocks	Inspect angle and size		
TF-TP Calibration Fixture	Inspect and calculate new constant		
CG-1001 Bench Calibrator Gage	Verify micrometer travel		
Thread Diameter Measurement Gage			
RG-7000, PG-6000, MRP-5000 Diameter Gages	Verify function and check parallelism		
Large Diameter Measurement Gages			
MIC 360 Gage	Verify wheel diameter and gage function		
API Gages/Standards			
Lead Gages	Calibrate indicator and verify function	Contact Us	Contact Us
Lead Standards	Inspect step/step per specification		
MRP® Gages (MRP-1000, -2000, -3000)	Inspect complete assembly		
MRP® Standard Set	Inspect rod lengths per specifications		
Thread Height Standards	Inspect groove depths per specifications		
Profile Gages	Verify profile with optical comparator		
Miscellaneous Equipment			
Indicators	Calibrate per specification	Contact Us	Contact Us
Thread Rolls	Calibrate per specification		
CMM Contract Inspection	Per customer specification		Contact Us

**Prices subject to change without notice.*

Note: ALL indicators or gages requiring repair will be quoted prior to any work being commenced. A purchase order or written approval for the repair work must be submitted and received before any repairs will be undertaken.

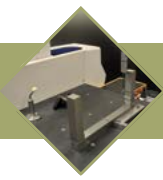

Calibration Certificates

Gagemaker provides two types of Calibration Certificates, the Certificate of Compliance and the Certificate of Calibration.

The Certificate of Compliance (Short Form) is issued to a product that has been inspected or verified to meet minimum prescribed requirements. Usually, it is applied to a fixed limit instrument with no adjustment capability.

The Certificate of Calibration (Long Form) is issued to products that have been inspected to the requirements of a prescribed engineering document while providing actual dimensional data.



Calibration Certificates

Certificates of Compliance (Short Form Certificate) - A certificate of compliance is issued to a product that has been inspected or verified to meet the minimum requirements of a prescribed engineering document or description. Normally this type of certificate is applied to a fixed limit instrument that has no adjustment capability. No dimensional values are included in this certificate.

The Compliance Certificate shall, as a minimum, include the following information: document title, name and address of the our office where the certification took place, the unique identification of the certificate in the form of a document number, name and address of the customer, identification of the method used to verify conformance, a description of the item verified, the date that the verification was completed, reference to specific procedures used in the verification process, verification results noted as Pass or Fail, the name and signature of the person authorized and responsible for the verification, and evidence that the verification is traceable.

Certificates of Calibration (Long Form Certificate) - The long form certificate is issued to products that have been inspected to requirements of a prescribed engineering document. The long form includes actual dimensional data with tolerance limits as noted on the inspection drawings or certification documents. This level of certificate provides the user with the exact dimensional data on the instrument when it left the Gagemaker facility.

The Calibration Certificate shall, as a minimum, include all items outlined for the Compliance Certificate with the addition of: calibration results noted by required, actual and dimensional deviation of each feature inspected.

Certificate Type	Price*
Certificate of Compliance – provided with all calibrations. Includes model number, serial number, traceability to NIST or other governing body, inspector's signature, calibration and recalibration date. Profile gages are issued certificates of compliance only.	
Certificate of Calibration – includes any documentation other than that listed under the Certificate of Compliance	35.00

**Prices subject to change without notice.*

Shipping & Care

Guide to Returning for Calibration or Repair

It is always best to return equipment in its original case and packaging. If you no longer have the original carton or gage case, always package gages securely in a carton and then secure in a second carton. If the gage has a sliding member, always lock the member in a secure position prior to placing in a carton. Loose components in a carton will damage the product in shipment and the cost of repair will be more. Most shipments get turned upside down and often times dropped during shipment, so plan to package for the worst conditions.



When returning products, please include the following:

- Contact name
- Company name
- Phone number
- E-mail address
- RMA (Return Material Authorization)(if available)
- Purchase Order or Work Order in the package
- Description of the work to be completed

Note: Incomplete or insufficient information will cause a delay in the repair or calibration process.

Basic Gage Care

- Keep all unprotected metal surfaces coated with light oil.
- Avoid dropping the gage or subjecting it to any vibration or impact.
- Keep the gage dry and away from any machine coolant spray.
- Do not force the movement of any of the mechanical parts. The mechanics are designed to move freely.
- Keep the indicator face clean.
- Never oil the indicator, as the oil will attract dirt and dust





Gagemaker Products



GAGEMAKER PRODUCTS





Pitch Diameter and Ovality Gages

MRP® Pitch Diameter and Ovality Gages

This MRP® series of pitch diameter (or crest diameter) gages detects variations in pitch diameter by the use of a gage shoe that rests on the crest of the threads. Variation in diameter is detected by the indicator readout. These gages must be set to nominal size with one of a variety of setting options offered. All of these gages are API approved for use on tubing and casing.

Model	Description	Range
MRP-202	Internal Small Pitch Diameter Thread Gauge	Internal 1" - 2½"
MRP-1001	External Pitch Diameter Gauge	External 1½" - 4½"
MRP-1000-45	Internal Seal Diameter Gauge. Contacts on a 45° angle. Arms: ⅜" upper arms, ⅜" lower arms	Internal 1" - 4½"
MRP-1003	External/Internal Pitch Diameter Gauge	1½" - 4½"
MRP-1007	Internal Seal Diameter Gauge. Contacts on a 45° angle. Arms: .740" upper, ½" lower	Internal 1½" - 4½"
MRP-1008	Internal Seal Diameter Gauge. Contacts on a 45° angle. Arms: .740" upper, .740" lower	Internal 1⅜" - 4½"
MRP-1009	Internal Seal Diameter Gauge. Contacts on a 45° angle. Arms: .740" upper, .500" lower	Internal 1⅜" - 4½"
MRP-1012-TSS	Internal/External Pitch Diameter Gauge for Two Step Seal. Upper and lower arms are .740" diameter. Upper arm has standard travel of .150". Shipped with T105 pts.	Internal 2⅜" - 4½" External 1¾" - 4½"
MRP-1012-TST	Internal/External Pitch Diameter Gauge, Two Step Thread, w/ 1.030" Horseshoe standoff for front and rear measurements. Arms have .740" diameter. Upper arm has extended travel of .350"	Internal 2⅜" - 4½" External 1¾" - 4½"
MRP-1500	Internal/External Pitch Diameter Gauge, Solid Body	Internal 1½" - 4½" External 2⅞" - 4½"
MRP-2001	External Pitch Diameter Gauge, 4½" reach	External 2⅜" - 20"
MRP-2001-S	External Pitch Diameter Gauge, 4½" reach, Straight Blocks	
MRP-2001-7	External Pitch Diameter Gauge, 7" reach	
MRP-2001-10	External Pitch Diameter Gauge, 10" reach	
MRP-2002	Internal Pitch Diameter Gauge, 4¼" reach	Internal 2⅜" - 20"
MRP-2002-S	Internal Pitch Diameter Gauge, 4¼" reach, Straight Blocks	
MRP-2002-7	Internal Pitch Diameter Gauge, 7" reach	Internal 3½" - 20"
MRP-2002-10	Internal Pitch Diameter Gauge, 10" reach	
MRP-2003	Internal/External Pitch Diameter Gauge, 4¼" reach	
MRP-2003-S	Internal/External Pitch Diameter Gauge, 4¼" reach, Straight Blocks	
MRP-2003-7	Internal/External Pitch Diameter Gauge, 7" reach	Internal 3½" - 20" External 2⅜" - 20"
MRP-2003-10	Internal/External Pitch Diameter Gauge, 10" reach	
MRP-2511	External Pitch Diameter Gauge, 4" reach	External 4½" - 9⅝"
MRP-2511-7	External Pitch Diameter Gauge, 7" reach	
MRP-2521	External Pitch Diameter Gauge, 4" reach	External 4½" - 13⅝" Internal 4½" - 9⅝"
MRP-2512	Internal Pitch Diameter Gauge, 3⅝" reach	
MRP-2512-7	Internal Pitch Diameter Gauge, 7" reach	
MRP-2522	Internal Pitch Diameter Gauge, 3⅝" reach	Internal 4½" - 13⅝"
MRP-2513	Internal/External PD Gauge, 3⅝" reach	
MRP-2523	Internal/External PD Gauge, 3⅝" reach	4½" - 13⅝"
MRP-3001	External Pitch Diameter Gauge, 3⅝" reach	
MRP-3002	Internal Pitch Diameter Gauge, 3⅝" reach	External 8⅝" - 24" Internal 8⅝" - 24"
MRP-3003	Internal/External Pitch Diameter Gauge, 3⅝" reach	
MRP-3004	Internal/External Pitch Diameter Gauge, 3⅝" reach	8⅝" - 24"
MRP-3501	External Pitch Diameter Gauge, w/ 6¼" reach	
MRP-3502	Internal Pitch Diameter Gauge, w/ 6¼" reach	20" - 36"
MRP-3503	Internal/External PD Gauge, w/ 6¼" reach	

MRP-1000, MRP-2000, & MRP-3000 Replacement Parts

These are some of the most commonly requested replacement parts for the MRP® gages. Additional parts may be available.

Model	Description
MRP-10BL	MRP-1000 Block Set
MRP-10UA	MRP-1000 Upper Arm
MRP-10LA	MRP-1000 Lower Arm
MRP-10WP	MRP-1000 Wear Pad Set
MRP-10SP	MRP-1000 Spring Plunger
MRP-11UA	MRP-1001 Upper Arm
MRP-20BL	MRP-2000 Block Set
MRP-20CL	MRP-2000 Series Arm Clamp
MRP-20LB-1	MRP-2000 Lower Block w/ 1" hole
MRP-21UA	MRP-2001 Upper Arm
MRP-21LA	MRP-2001 Lower Arm
MRP-21UA-7	MRP-2001 7" Upper Arm
MRP-21LA-7	MRP-2001 7" Lower Arm
MRP-21UA-10	MRP-2001 10" Upper Arm
MRP-21LA-10	MRP-2001 10" Lower Arm
MRP-.625I	Int. Thread Shoe, 5/8" long, .125 Pivot Dimension
MRP-.625E	Ext. Thread Shoe, 5/8" long, .250 Pivot Dimension
MRP-20mm	Int./Ext. Thread Shoe, 20 mm long, .250 Pivot Dimension
MRP-20SP	MRP-2000 Spring Plunger
MRP-22UA	MRP-2002 Upper Arm
MRP-22LA	MRP-2002 Lower Arm
MRP-22UA-7	MRP-2002 7" Upper Arm
MRP-22LA-7	MRP-2002 7" Lower Arm
MRP-22UA-10	MRP-2002 10" Upper Arm
MRP-22LA-10	MRP-2002 10" Lower Arm
MRP-20WP	MRP-2000 Wear Pad Set
MRP-20WPEX	MRP-2000 Extended Wear Pad Set
MRP-20WP-7	MRP-2000 Wear Pad Set, 7" reach
MRP-20WP-10	MRP-2000 Wear Pad Set, 10" reach
MRP-RAIL-12	MRP-2000 12" Cross Rail Set
MRP-RAIL-18	MRP-2000 18" Cross Rail Set
MRP-RAIL-24	MRP-2000 24" Cross Rail Set
MRP-10KB-S	MRP-1000 Knob-Short
MRP-10KB-L	MRP-1000 Knob-Long
MRP-20KB	MRP-2000 Knob
MRP-.750	Ext. Thread Shoe, 3/4" long, .250 Pivot Dimension
MRP-.875	Int./Ext. Thread Shoe, 7/8" long, .250 Pivot Dimension
MRP-1.00	Int./Ext. Thread Shoe, 1" long, .250 Pivot Dimension
MRP-30WP	MRP-3000 Wear Pad Set
MRP-30WPEX	MRP-3000 Extended Wear Pad Set
MRP-30RS-18	MRP-3000 Rail Set, 18" Max
MRP-30RS-24	MRP-3000 Rail Set, 24" Max
MRP-GSS	MRP® Gage Setting Stand





Pin Rod Standard
in Case



Pin Rod
Standard "A"

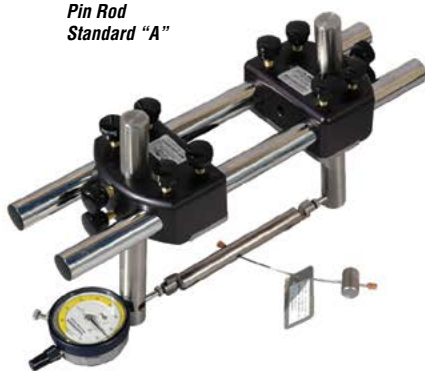

Pin Rod Standard "B"



MRP® Gage Setting Standards

Rod Style Setting Standards for MRP-1000, 1500, 2000, 2500, 3000, & 3500

Rod style setting standards are designed to preset select **MRP®** Series models for accurate inspection of API threaded connections. Each set of standards consists of two precision ground rods that are ground to lengths in accordance with API Specification 5B. The rod sets are securely attached together and labeled with the connection size and serial number. The rods set the location of the thread shoe and the distance between shoes for accurate inspection of threaded connections.

Thread Type	Connection Size	Pin Model	Box Model
EUE	2 $\frac{3}{8}$ " EUE	MRP5B-238EUE-P	MRP5B-238EUE-B
	2 $\frac{7}{8}$ " EUE	MRP5B-278EUE-P	MRP5B-278EUE-B
	3 $\frac{1}{2}$ " EUE	MRP5B-312EUE-P	MRP5B-312EUE-B
	4" EUE	MRP5B-4EUE-P	MRP5B-4EUE-B
	4 $\frac{1}{2}$ " EUE	MRP5B-412EUE-P	MRP5B-412EUE-B

Thread Type	Connection Size	Pin Model	Box Model
NUE	2 $\frac{3}{8}$ " NUE	MRP5B-238NUE-P	MRP5B-238NUE-B
	2 $\frac{7}{8}$ " NUE	MRP5B-278NUE-P	MRP5B-278NUE-B
	3 $\frac{1}{2}$ " NUE	MRP5B-312NUE-P	MRP5B-312NUE-B
	4" NUE	MRP5B-4NUE-P	MRP5B-4NUE-B
	4 $\frac{1}{2}$ " NUE	MRP5B-412NUE-P	MRP5B-412NUE-B

Thread Type	Connection Size	Pin Model	Box Model
Buttress	4 $\frac{1}{2}$ " Buttress	MRP5B-412B-P	MRP5B-412B-B
	5" Buttress	MRP5B-5B-P	MRP5B-5B-B
	5 $\frac{1}{2}$ " Buttress	MRP5B-512B-P	MRP5B-512B-B
	6 $\frac{5}{8}$ " Buttress	MRP5B-658B-P	MRP5B-658B-B
	7" Buttress	MRP5B-7B-P	MRP5B-7B-B
	7 $\frac{5}{8}$ " Buttress	MRP5B-758B-P	MRP5B-758B-B
	8 $\frac{5}{8}$ " Buttress	MRP5B-858B-P	MRP5B-858B-B
	9 $\frac{5}{8}$ " Buttress	MRP5B-958B-P	MRP5B-958B-B
	10 $\frac{3}{4}$ " Buttress	MRP5B-1034B-P	MRP5B-1034B-B
	11 $\frac{3}{4}$ " Buttress	MRP5B-1134B-P	MRP5B-1134B-B
	13 $\frac{3}{8}$ " Buttress	MRP5B-1338B-P	MRP5B-1338B-B
	16" Buttress	MRP5B-16B-P	MRP5B-16B-B
	18 $\frac{5}{8}$ " Buttress	MRP5B-1858B-P	MRP5B-1858B-B
	20" Buttress	MRP5B-20B-P	MRP5B-20B-B

Line Pipe standards are available. All Special Orders, Non-Standard API or Premium Connection Setting Standards are extra. Please contact for more information.

Rod Style Setting Standards for MRP-1000, 1500, 2000, 2500, 3000, & 3500 (Cont.)

Thread Type	Connection Size	Pin Model	Box Model
LTC	4½" 8R LTC	MRP5B-412L-P	MRP5B-412L-B
	5" 8R LTC	MRP5B-5L-P	MRP5B-5L-B
	5½" 8R LTC	MRP5B-512L-P	MRP5B-512L-B
	6¾" 8R LTC	MRP5B-658L-P	MRP5B-658L-B
	7" 8R LTC	MRP5B-7L-P	MRP5B-7L-B
	7¾" 8R LTC	MRP5B-758L-P	MRP5B-758L-B
	8¾" 8R LTC	MRP5B-858L-P	MRP5B-858L-B
	9¾" 8R LTC	MRP5B-958L-P	MRP5B-958L-B>P110 or MRP5B-958L-B<P110
	20" 8R LTC	MRP5B-20L-P	MRP5B-20L-B>JK55 or MRP5B-20L-B<JK55

Thread Type	Connection Size	Pin Model	Box Model
STC	4½" - 9.50# 8R STC	MRP5B-412S-9-P	MRP5B-412S-9-B
	4½" - Other 8R STC	MRP5B-412S-0-P	MRP5B-412S-0-B
	5" - 11.50# 8R STC	MRP5B-5S-11-P	MRP5B-5S-11-B
	5" - Other 8R STC	MRP5B-5S-0-P	MRP5B-5S-0-B
	5½" 8R STC	MRP5B-512S-P	MRP5B-512S-B
	6¾" 8R STC	MRP5B-658S-P	MRP5B-658S-B
	7" - 17.00# 8R STC	MRP5B-7S-17-P	MRP5B-7S-17-B
	7" - Other 8R STC	MRP5B-7S-0-P	MRP5B-7S-0-B
	7¾" 8R STC	MRP5B-758S-P	MRP5B-758S-B
	8¾" - 24.00# 8R STC	MRP5B-858S-24-P	MRP5B-858S-24-B
	8¾" - Other 8R STC	MRP5B-858S-0-P	MRP5B-858S-0-B
	9¾" 8R STC	MRP5B-958S-P	MRP5B-958S-B≥P110 or MRP5B-958S-B<P110
	10¾" - 32.75# 8R STC	MRP5B-1034S-32-P	MRP5B-1034S-32-B
	10¾" - Other 8R STC	MRP5B-1034S-0-P	MRP5B-1034S-0-B≥P110 or MRP5B-1034S-0-B<P110
	11¾" 8R STC	MRP5B-1134S-P	MRP5B-1134S-B≥P110 or MRP5B-1134S-B<P110
	13¾" 8R STC	MRP5B-1338S-P	MRP5B-1338S-B≥P110 or MRP5B-1338S-B<P110
	16" 8R STC	MRP5B-16S-P	MRP5B-16S-B
	18¾" 8R STC	MRP5B-1858S-P	MRP5B-1858S-B
	20" 8R STC	MRP5B-20S-P	MRP5B-20S-B≥JK55 or MRP-20S-B<JK55

Box Rod Standard in Case



Box Rod Standard "A"

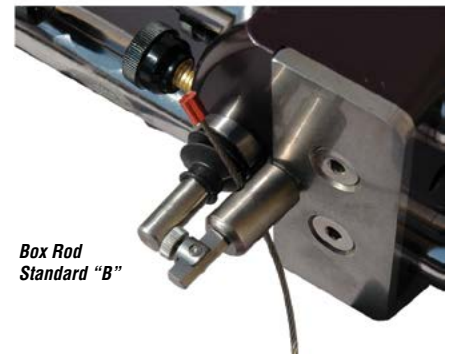

Box Rod Standard "B"

Line Pipe standards are available. All Special Orders, Non-Standard API or Premium Connection Setting Standards are extra. Please contact for more information.

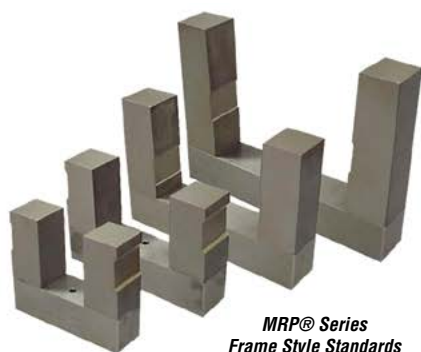

MRP® Series
Frame Style Standards



MRP® Series External
Frame Style Standard



MRP® Series Internal
Frame Style Standard

Frame Style Setting Standards for MRP-1000, 1500, 2000, 2500, 3000, & 3500 Series*

These frame style setting standards are designed to preset multiple models of the **MRP®** Series gages for accurate inspection of API threaded connections. These standards consist of a rigid, non-adjustable steel block precision machined to proper size to tolerances of ± 0.0003 ". Round style standards, smaller than 2 $\frac{1}{2}$ ", are available as specials (contact us directly for more information). **When ordering, please specify the gage to be used.**

Thread Type	Connection Size	Pin Model	Box Model
NUE	2 $\frac{3}{8}$ " NUE	FS5B-238N-P2	FS5B-238N-B2
	2 $\frac{1}{2}$ " NUE	FS5B-278N-P2	FS5B-278N-B2
	3 $\frac{1}{2}$ " NUE	FS5B-312N-P2	FS5B-312N-B2
	4 $\frac{1}{2}$ " NUE	FS5B-412N-P2	FS5B-412N-B2

Thread Type	Connection Size	Pin Model	Box Model
EUE	2 $\frac{3}{8}$ " EUE	FS5B-238E-P2	FS5B-238E-B2
	2 $\frac{1}{2}$ " EUE	FS5B-278E-P2	FS5B-278E-B2
	3 $\frac{1}{2}$ " EUE	FS5B-312E-P2	FS5B-312E-B2
	4 $\frac{1}{2}$ " EUE	FS5B-412E-P2	FS5B-412E-B2

Thread Type	Connection Size	Pin Model	Box Model
Buttress	4 $\frac{1}{2}$ " Buttress	FS5B-412B-P2	FS5B-412B-B2
	5" Buttress	FS5B-5B-P2	FS5B-5B-B2
	5 $\frac{1}{2}$ " Buttress	FS5B-512B-P2	FS5B-512B-B2
	6 $\frac{1}{8}$ " Buttress	FS5B-658B-P2	FS5B-658B-B2
	7" Buttress	FS5B-7B-P2	FS5B-7B-B2
	7 $\frac{7}{8}$ " Buttress	FS5B-758B-P2	FS5B-758B-B2
	8 $\frac{5}{8}$ " Buttress	FS5B-858B-P2	FS5B-858B-B2
	9 $\frac{1}{8}$ " Buttress	FS5B-958B-P2	FS5B-958B-B2
	10 $\frac{3}{4}$ " Buttress	FS5B-1034B-P2	FS5B-1034B-B2
	11 $\frac{3}{4}$ " Buttress	FS5B-1134B-P2	FS5B-1134B-B2
	13 $\frac{3}{8}$ " Buttress	FS5B-1338B-P2	FS5B-1338B-B2
	16" Buttress	FS5B-16B-P2	FS5B-16B-B2
	18 $\frac{5}{8}$ " Buttress	FS5B-1858B-P2	FS5B-1858B-B2
	20" Buttress	FS5B-20B-P2	FS5B-20B-B2

Thread Type	Connection Size	Pin Model	Box Model
LTC	4 $\frac{1}{2}$ " 8R LTC	FS5B-412L-P2	FS5B-412L-B2
	5" 8R LTC	FS5B-5L-P2	FS5B-5L-B2
	5 $\frac{1}{2}$ " 8R LTC	FS5B-512L-P2	FS5B-512L-B2
	6 $\frac{1}{8}$ " 8R LTC	FS5B-658L-P2	FS5B-658L-B2
	7" 8R LTC	FS5B-7L-P2	FS5B-7L-B2
	7 $\frac{7}{8}$ " 8R LTC	FS5B-758L-P2	FS5B-758L-B2
	8 $\frac{5}{8}$ " 8R LTC	FS5B-858L-P2	FS5B-858L-B2
	9 $\frac{1}{8}$ " 8R LTC	FS5B-958L-P2	FS5B-958L-B2 \geq P110 or FS5B-958L-B2<P110
	20" 8R LTC	FS5B-20L-P2	FS5B-20L-B2 \geq JK55 or FS5B-20L-B2<JK55

*Standards for Tubing and Casing Connections for MRP-5000 gages are available. Special Orders, Non Standard API, Round or Premium Connection Setting Standards are available.

Frame Style Setting Standards for MRP-1000, 1500, 2000, 2500, 3000, & 3500 Series* (Cont.)

Thread Type	Connection Size	Pin Model	Box Model
STC	4½" - 9.50# 8R STC	FS5B-412S-9-P2	FS5B-412S-9-B2
	4½" - Other 8R STC	FS5B-412S-0-P2	FS5B-412S-0-B2
	5" - 11.50# 8R STC	FS5B-5S-11-P2	FS5B-5S-0-B2
	5" - Other 8R STC	FS5B-5S-0-P2	FS5B-5S-0-B2
	5½" 8R STC	FS5B-512S-P2	FS5B-512S-B2
	6⅝" 8R STC	FS5B-658S-P2	FS5B-658S-B2
	7" - 17.00# 8R STC	FS5B-7S-17-P2	FS5B-7S-17-B2
	7" - Other 8R STC	FS5B-7S-0-P2	FS5B-7S-0-B2
	7⅝" 8R STC	FS5B-758S-P2	FS5B-758S-B2
	8⅝" - 24.00# 8R STC	FS5B-858S-24-P2	FS5B-858S-24-B2
	8⅝" - Other 8R STC	FS5B-858S-0-P2	FS5B-858S-0-B2
	9⅝" 8R STC	FS5B-958S-P2	FS5B-958S-B2 _≥ P110 or FS5B-958S-B2<P110
	10¾" - 32.75# 8R STC	FS5B-1034S-32-P2	FS5B-1034S-32-B2
	10¾" - Other 8R STC	FS5B-1034S-0-P2	FS5B-1034S-0-B2 _≥ P110 or FS5B-1034S-0-B2<P110
	11¾" 8R STC	FS5B-1134S-P2	FS5B-1134S -B2 _≥ P110 or FS5B-1134S-B2<P110
	13⅜" 8R STC	FS5B-1338S-P2	FS5B-1338S-B2 _≥ P110 or FS5B-1338S-B2<P110
	16" 8R STC	FS5B-16S-P2	FS5B-16S-B2
	18⅝" 8R STC	FS5B-1858S-P2	FS5B-1858S-B2
	20" 8R STC	FS5B-20S-P2	FS5B-20S-B2 _≥ JK55 or FS5B-20S-B2<JK55

*Standards for Tubing and Casing Connections for MRP-5000 gages are available. Special Orders, Non Standard API, Round or Premium Connection Setting Standards are available.



Tapered Thread Functional Size

MRP® Functional Roll Gages for Tapered Threads (MRP-5000)

The MRP-5000 series of thread pitch diameter gages use hardened and ground thread rolls to inspect functional size of tapered threaded connections. The MRP-5000 gages are adjustable within a size range and have interchangeable thread rolls for inspection of all API thread forms. The gages must be preset to size using one of a variety of setting methods available. Refer to the setting options that follow. Please specify preferred taper arms when ordering. **Thread rolls and standards are sold separately.**

Model	Description	Resolution	Range
MRP-501*	External Sizes by Taper, Single Taper*	.0001"	1" - 2¼"
MRP-502*	Internal Sizes by Taper, Single Taper*	.0001"	1" - 2¼"
MRP-5001	Internal/External Tubing and Casing Connections	.0005"	2¾" - 5½"
MRP-5002	Internal/External Tubing and Casing Connections	.0005"	2¾" - 13¾"
MRP-5003	Internal/External Tubing and Casing Connections	.0005"	13¾" - 20"
MRP-5004	Internal/External Tubing and Casing Connections	.0005"	2¾" - 9¾"

*Please specify taper when ordering. Built to one specific taper. One taper per gage. Set of thread rolls included.

MRP-5000 Replacement Parts

Model	Description*
MRP5-10	Positioning Springs (Set of 2)
MRP5-11	Retainer Washers (Set of 2)
MRP5-12	Lock Screws (Set of 2)
MRP5-75T	¾" TPF Taper Arms (Set of 2)
MRP5-10T	1" TPF Taper Arms (Set of 2)

*Taper arm price does not include thread rolls.

To determine the thread rolls required, refer to thread roll chart below.

MRP-5000 Thread Rolls

The product thread form determines the thread roll set that will be used. Thread roll sets consist of two rolls supplied in a labeled storage tube.

Model	Description
TR-8R	All API 8 Round Tubing
TR-10R	All API 10 Round Tubing
TR-8LP	8V API Line Pipe
TR-11LP	11½ TPI V API Line Pipe
TR-B10I	API Buttress Casing, Internal, 16" - 20"
TR-B10E	API Buttress Casing, External, 16" - 20"
TR-B75	API Buttress Casing, 4½" - 13¾"
TR-BL	Blank thread roll set

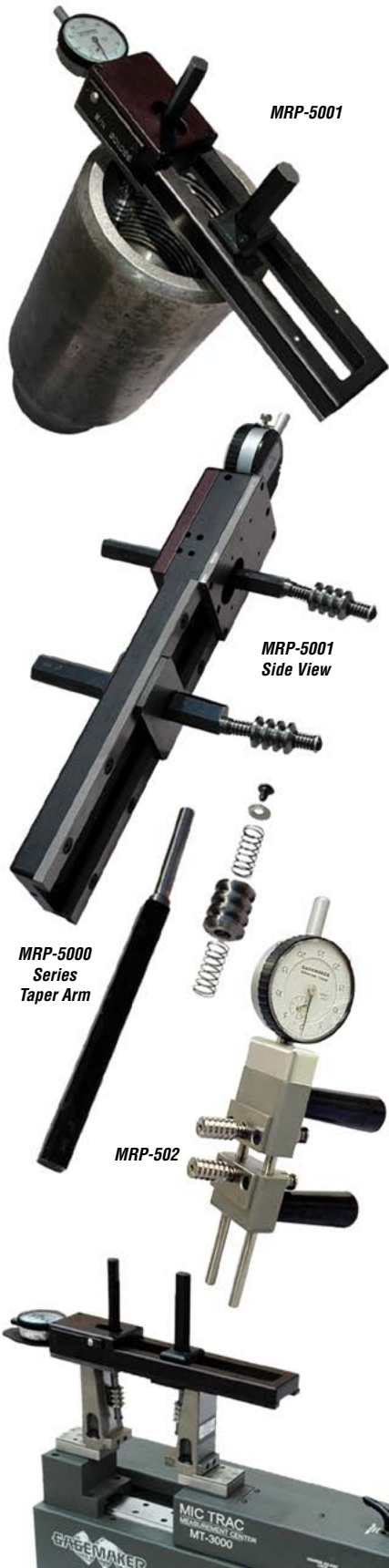

Frame Style Setting Standards

MRP-5000 Series Setting Standards for Tubing and Casing Connections*

These frame style setting standards are designed to preset **MRP-5000** Series gages for accurate inspection of API threaded connections. These standards consist of a rigid, non-adjustable steel block precision machined to proper size to tolerances of $\pm .0003"$.



Setting an MRP-5001 with Frame Style Standards

Thread Type	Connection Size	Pin Model	Box Model
NUE	2 $\frac{1}{8}$ " NUE	FSTD-238N-P5	FSTD-238N-B5
	2 $\frac{1}{4}$ " NUE	FSTD-278N-P5	FSTD-278N-B5
	3 $\frac{1}{2}$ " NUE	FSTD-312N-P5	FSTD-312N-B5
	4 $\frac{1}{2}$ " NUE	FSTD-412N-P5	FSTD-412N-B5
EUE	2 $\frac{1}{8}$ " EUE	FSTD-238E-P5	FSTD-238E-B5
	2 $\frac{1}{4}$ " EUE	FSTD-278E-P5	FSTD-278E-B5
	3 $\frac{1}{2}$ " EUE	FSTD-312E-P5	FSTD-312E-B5
	4 $\frac{1}{2}$ " EUE	FSTD-412E-P5	FSTD-412E-B5
Buttress	4 $\frac{1}{2}$ " Buttress	FSTD-412B-P5	FSTD-412B-B5
	5" Buttress	FSTD-5B-P5	FSTD-5B-B5
	5 $\frac{1}{2}$ " Buttress	FSTD-512B-P5	FSTD-512B-B5
	6 $\frac{1}{8}$ " Buttress	FSTD-658B-P5	FSTD-658B-B5
	7" Buttress	FSTD-7B-P5	FSTD-7B-B5
	7 $\frac{1}{8}$ " Buttress	FSTD-758B-P5	FSTD-758B-B5
	8 $\frac{1}{8}$ " Buttress	FSTD-858B-P5	FSTD-858B-B5
	9 $\frac{1}{8}$ " Buttress	FSTD-958B-P5	FSTD-958B-B5
	10 $\frac{3}{4}$ " Buttress	FSTD-1034B-P5	FSTD-1034B-B5
	11 $\frac{3}{4}$ " Buttress	FSTD-1134B-P5	FSTD-1134B-B5
	13 $\frac{3}{8}$ " Buttress	FSTD-1338B-P5	FSTD-1338B-B5
	16" Buttress	FSTD-16B-P5	FSTD-16B-B5
	18 $\frac{5}{8}$ " Buttress	FSTD-1858B-P5	FSTD-1858B-B5
	20" Buttress	FSTD-20B-P5	FSTD-20B-B5
LTC	4 $\frac{1}{2}$ " 8R LTC	FSTD-412L-P5	FSTD-412L-B5
	5" 8R LTC	FSTD-5L-P5	FSTD-5L-B5
	5 $\frac{1}{2}$ " 8R LTC	FSTD-512L-P5	FSTD-512L-B5
	6 $\frac{1}{8}$ " 8R LTC	FSTD-658L-P5	FSTD-658L-B5
	7" 8R LTC	FSTD-7L-P5	FSTD-7L-B5
	7 $\frac{1}{8}$ " 8R LTC	FSTD-758L-P5	FSTD-758L-B5
	8 $\frac{1}{8}$ " 8R LTC	FSTD-858L-P5	FSTD-858L-B5
	9 $\frac{1}{8}$ " 8R LTC	FSTD-958L-P5	FSTD-958L-B5 \geq P110 or FSTD-958L-B5<P110
	20" 8R LTC	FSTD-20L-P5	FSTD-20L-B5 \geq JK55 or FSTD-20L-B5<JK55
	STC	4 $\frac{1}{2}$ " - 9.50# 8R STC	FSTD-412S-9-P5
4 $\frac{1}{2}$ " - Other 8R STC		FSTD-412S-0-P5	FSTD-412S-0-B5
5" - 11.50# 8R STC		FSTD-5S-11-P5	FSTD-5S-0-B5
5" - Other 8R STC		FSTD-5S-0-P5	FSTD-5S-0-B5
5 $\frac{1}{2}$ " 8R STC		FSTD-512S-P5	FSTD-512S-B5
6 $\frac{1}{8}$ " 8R STC		FSTD-658S-P5	FSTD-658S-B5
7" - 17.00# 8R STC		FSTD-7S-17-P5	FSTD-7S-17-B5
7" - Other 8R STC		FSTD-7S-0-P5	FSTD-7S-0-B5
7 $\frac{1}{8}$ " 8R STC		FSTD-758S-P5	FSTD-758S-B5
8 $\frac{1}{8}$ " - 24.00# 8R STC		FSTD-858S-24-P5	FSTD-858S-24-B5
8 $\frac{1}{8}$ " - Other 8R STC		FSTD-858S-0-P5	FSTD-858S-0-B5
9 $\frac{1}{8}$ " 8R STC		FSTD-958S-P5	FSTD-958S-B5 \geq P110 or FSTD-958S-B5<P110
10 $\frac{3}{4}$ " - 32.75# 8R STC		FSTD-1034S-32-P5	FSTD-1034S-32-B5
10 $\frac{3}{4}$ " - Other 8R STC		FSTD-1034S-0-P5	FSTD-1034S-0-B5 \geq P110 or FSTD-1034S-0-B5<P110
11 $\frac{3}{4}$ " 8R STC		FSTD-1134S-P5	FSTD-1134S-B5 \geq P110 or FSTD-1134S-B5<P110
13 $\frac{3}{8}$ " 8R STC		FSTD-1338S-P5	FSTD-1338S-B5 \geq P110 or FSTD-1338S-B5<P110
16" 8R STC		FSTD-16S-P5	FSTD-16S-B5
18 $\frac{5}{8}$ " 8R STC		FSTD-1858S-P5	FSTD-1858S-B5
20" 8R STC		FSTD-20S-P5	FSTD-20S-B5 \geq JK55 or FSTD-20S-B5<JK55



MRP-5000 Frame Style Box Standard



MRP-5000 Frame Style Pin Standard



*Rotary Shouldered Connection pin and custom standards are available. Please contact Gagemaker for more information.



LPB-4-2-50



LPB-3.5-2-H9



LPP-3.5-2-H9



LPP-6-1.5-55



LPP on a Pin with blue line marking proper thread



LPB on a Box cutout

Pitch Diameter

Pitch Diameter is one of the most important inspections for nearly any thread. In the past, pitch diameter was ignored as long as the ring or plug gage threaded. Now, using Gagemaker gages, you have more control over threading connections of marginal quality. The process of locating and measuring the pitch diameter takes less than a minute. This minute of inspection quickly decides the difference between good and bad.

Rotary Shouldered Connection Pitch Diameter Location Profiles

Pitch diameter location templates locate the point on the connection where the pitch diameter is measured. When applied properly to the connection, the template's special layout mark indicates the proper thread to measure the pitch diameter. A simple mark with a felt tip marking pen allows the operator or inspector to accurately position the gage and read a diameter. Please specify the threads per inch (TPI), taper per foot (TPF), and thread form when ordering.

Box Profiles

Model	Description
LPB-3-1.25-SLH9	Box Location Profile template for 3 TPI, 1.25 TPF, 90-V-0.084 thread form
LPB-3.5-2-H9	Box Location Profile template for 3.5 TPI, 2 TPF, 90-V-0.050 thread form
LPB-3.5-3-H9	Box Location Profile template for 3.5 TPI, 3 TPF, 90-V-0.050 thread form
LPB-4-1.5-76	Box Location Profile template for 4 TPI, 1.50 TPF, V-0.076 thread form
LPB-4-2-38	Box Location Profile template for 4 TPI, 2 TPF, V-0.038R thread form
LPB-4-2-50	Box Location Profile template for 4 TPI, 2 TPF, V-0.050 thread form
LPB-4-3-38	Box Location Profile template for 4 TPI, 3 TPF, V-0.038R thread form
LPB-4-3-50	Box Location Profile template for 4 TPI, 3 TPF, V-0.050 thread form
LPB-4-3.375-A094	Box Location Profile template for 4 TPI, 3.375 TPF, A-0.094 thread form
LPB-5-3-40	Box Location Profile template for 5 TPI, 3 TPF, V-0.040 thread form
LPB-6-1.0-55	Box Location Profile template for 6 TPI, 1.0 TPF, V-0.055 thread form
LPB-6-1.5-55	Box Location Profile template for 6 TPI, 1.50 TPF, V-0.055 thread form
LPB-6-2-32	Box Location Profile template for 6 TPI, 2 TPF, V-0.032 thread form

Pin Profiles

Model	Description
LPP-3-1.25-SLH9	Pin Location Profile template for 3 TPI, 1.25 TPF, 90-V-0.084 thread form
LPP-3.5-2-H9	Pin Location Profile template for 3.5 TPI, 2 TPF, 90-V-0.050 thread form
LPP-3.5-3-H9	Pin Location Profile template for 3.5 TPI, 3 TPF, 90-V-0.050 thread form
LPP-4-1.5-76	Pin Location Profile template for 4 TPI, 1.50 TPF, V-0.076 thread form
LPP-4-2-38	Pin Location Profile template for 4 TPI, 2 TPF, V-0.038R thread form
LPP-4-2-50	Pin Location Profile template for 4 TPI, 2 TPF, V-0.050 thread form
LPP-4-3-38	Pin Location Profile template for 4 TPI, 3 TPF, V-0.038R thread form
LPP-4-3-50	Pin Location Profile template for 4 TPI, 3 TPF, V-0.050 thread form
LPP-4-3.375-A094	Pin Location Profile template for 4 TPI, 3.375 TPF, A-0.094 thread form
LPP-5-3-40	Pin Location Profile template for 5 TPI, 3 TPF, V-0.040 thread form
LPP-6-1.0-55	Pin Location Profile template for 6 TPI, 1.0 TPF, V-0.055 thread form
LPP-6-1.5-55	Pin Location Profile template for 6 TPI, 1.50 TPF, V-0.055 thread form
LPP-6-2-32	Pin Location Profile template for 6 TPI, 2 TPF, V-0.032 thread form

RSC Box Pitch Diameter Gages

Gagemaker's internal diameter and groove gages measure variation in internal bore diameters. Pitch diameter gages are shipped with two 0.144" diameter contact points (T144) as standard. Setting dimensions for the pitch diameter gages are provided by the TDWIN Taper™ software. **Software is sold separately (see page 129).** Refer to page 124 for the proper contact point for your particular connection.

Model	Description	Range
IT-5104-RSC	Internal Diameter/Groove Gage, 4" (101.6 mm) Depth	1½" - 10" (38.1 mm - 254 mm) Dia.
IT-5104-04	Replacement Lower Arm	4¼" (107.9 mm) Length

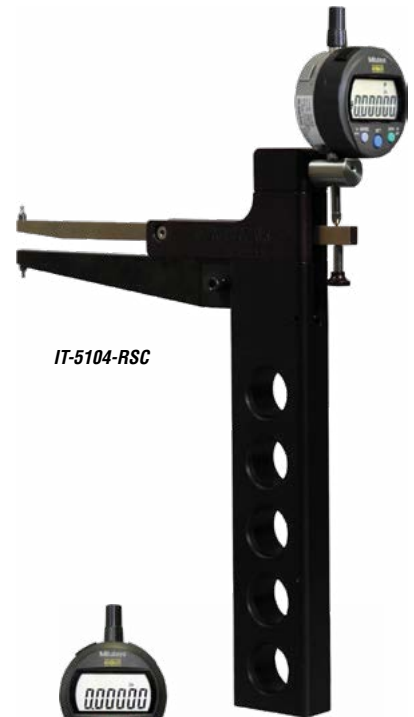

IT-5104-RSC

RSC Pin Pitch Diameter Gages

The ball pitch diameter gages indicate the pitch diameter size of the product's external thread. The gages are adjustable within a size range and use interchangeable contact points to measure different pitch threads. Gages are shipped with two 0.144" diameter contact points (T144) as standard. Reference page 124 for other connection specific contact points.

Model	Description	Range
PD-8001-RSC	External Ball Pitch Diameter Gage	0" - 6" (0 mm - 152.4 mm)
PD-8002-RSC	External Ball Pitch Diameter Gage	6" - 12" (152.4 mm - 304.8 mm)



PD-8001-RSC

Rod Style Setting Standards

Rod style setting standards are used to set many JSS® gages. Specify size or specific connection when ordering. Ex.: RS-3.5-DS-B, RS-NC77-B, RS-2.375-REG-B.

Model	Description
RS-__-DS-B	Rod Standard for Double Streamline (3.5" - 5.5"), Box
RS-__-DS-P	Rod Standard for Double Streamline (3.5" - 5.5"), Pin
RS-__-EF-B	Rod Standard for External Flush (2.375" - 4.5"), Box
RS-__-EF-P	Rod Standard for External Flush (2.375" - 4.5"), Pin
RS-__-FH-B	Rod Standard for Full Hole (2.875" - 6.625"), Box
RS-__-FH-P	Rod Standard for Full Hole (2.875" - 6.625"), Pin
RS-__-H9-B	Rod Standard for H-90 (3.5" - 8.625"), Box
RS-__-H9-P	Rod Standard for H-90 (3.5" - 8.625"), Pin
RS-__-IF-B	Rod Standard for Internal Flush (2.375" - 6.625"), Box
RS-__-IF-P	Rod Standard for Internal Flush (2.375" - 6.625"), Pin
RS-NC__-B	Rod Standard for API Numbered Connections (#10 - #77), Box
RS-NC__-P	Rod Standard for API Numbered Connections (#10 - #77), Pin
RS-__-OH-B	Rod Standard for Open Hole (2.375" - 4.5"), Box
RS-__-OH-P	Rod Standard for Open Hole (2.375" - 4.5"), Pin
RS-__-PAC-B	Rod Standard for PAC (2.375" - 3.5"), Box
RS-__-PAC-P	Rod Standard for PAC (2.375" - 3.5"), Pin
RS-__-SH-B	Rod Standard for Slim Hole (2.375" - 4.5"), Box
RS-__-SH-P	Rod Standard for Slim Hole (2.375" - 4.5"), Pin
RS-__-SLH9-B	Rod Standard for Slimline H-90 (2.375" - 3.5"), Box
RS-__-SLH9-P	Rod Standard for Slimline H-90 (2.375" - 3.5"), Pin
RS-__-REG-B	Rod Standard for Regular (1.0" - 8.625"), Box
RS-__-REG-P	Rod Standard for Regular (1.0" - 8.625"), Pin
RS-__-XH-B	Rod Standard for Xtra Hole (2.875" - 5.0"), Box
RS-__-XH-P	Rod Standard for Xtra Hole (2.875" - 5.0"), Pin
RS-__-WO-B	Rod Standard for Wide Open (2.375" - 4.5"), Pin
RS-__-WO-P	Rod Standard for Wide Open (2.375" - 4.5"), Pin



Setting PD-8001-RSC with Rod Standard



PD-8001



PD-6000



PD-6001 and Extension Rods

Straight Thread External Pitch Diameter Gages (0" to 72" Diameters)

The ball pitch diameter gages or "GO/NO GO" gages indicate the pitch diameter size of the product's external thread. The gages are adjustable within a size range and use interchangeable contact points to measure different pitch threads. Setting dimensions for the pitch diameter gages are provided by the TDWIN software. **Software (see page 128) and contact points (see pages 124-125) are sold separately.** Indicators have a 1/2" travel and .0005" resolution, and higher resolutions are available. Models PD-8004 through PD-8016 include a custom wood case.

Model	Description	Range
PD-8000	External Ball Pitch Diameter Gage	0" - 2 3/8" (0 mm - 60.3 mm)
PD-8001	External Ball Pitch Diameter Gage	0" - 6" (0 mm - 152.4 mm)
PD-8002	External Ball Pitch Diameter Gage	6" - 12" (152.4 mm - 304.8 mm)
PD-8004	External Ball Pitch Diameter Gage	12" - 16" (304.8 mm - 406.4 mm)
PD-8006	External Ball Pitch Diameter Gage	16" - 20" (406.4 mm - 508 mm)
PD-8008	External Ball Pitch Diameter Gage	20" - 24" (508 mm - 609.6 mm)
PD-8010	External Ball Pitch Diameter Gage	24" - 28" (609.6 mm - 711.2 mm)
PD-8012	External Ball Pitch Diameter Gage	28" - 36" (711.2 mm - 914.4 mm)
PD-8013	External Ball Pitch Diameter Gage	36" - 44" (914.4 mm - 1117.6 mm)
PD-8014	External Ball Pitch Diameter Gage	44" - 52" (1117.6 mm - 1320.8 mm)
PD-8015	External Ball Pitch Diameter Gage	52" - 60" (1320.8 mm - 1524.0 mm)
PD-8016	External Ball Pitch Diameter Gage	60" - 72" (1524.0 mm - 1828.8 mm)

Straight Thread Internal Pitch Diameter Gages (1 1/2" to 27" Diameters)

The ball pitch diameter gages or "GO/NO GO" gages indicate the pitch diameter size of the product's internal threads. The gages are adjustable within a size range and use interchangeable contact points to measure different pitch threads. Setting dimensions for the pitch diameter gages are provided by the TDWIN software (sold separately, see page 128). Higher resolution indicators are available. All of the PD-6000 series are sold without contact points. See pages 124-125 for contact points.

Model	Description	Travel	Resolution	Range
PD-6000	Internal Pitch Diameter Gage ("V" & Acme)	1/2"	.0005"	1 1/2" - 9"
PD-6000-07	Replacement Arm Set			4 1/2" length
PD-6001	Internal Pitch Diameter Gage	1/2"	.0005"	6" - 24"

PD-6001 Replacement Parts (Extensions have #10-32 threads)

Model	Description	Length
PD-6001-PD4M	Cap	
4-2-617	Indicator Base - Mitutoyo Indicator Only	
PD-6001-CBA	Cap and Base Assembly	
PD-6001-PD3	Adjustment Cap Lock Nut	
PD-6001-PD2	Adjustment Cap	
PD-6001-PD1	Contact Point Adapter	
PD-6001-PDA	Extension Rod	.430"
PD-6001-PDB	Extension Rod	.860"
PD-6001-PDC	Extension Rod	1.290"
PD-6001-PDD	Extension Rod	1.720"
PD-6001-PDE	Extension Rod	3.440"
PD-6001-PDF	Extension Rod	5.590"
PD-6001-PDG	Extension Rod	7.740"
PD-6001-PDH	Extension Rod	10.320"
PD-6001-12E	PD-6001 Internal Pitch Diameter Extension Rod	12"
PD-6001-24E	PD-6001 Internal Pitch Diameter Extension Rod	24"
PD-6001-36E	PD-6001 Internal Pitch Diameter Extension Rod	36"

Thread Taper

External Taper Gages

Gagemaker's external taper gages inspect variation in connection taper. External taper gages are shipped with .072" diameter contact points as standard. Refer to page 124 for the proper contact point for your particular connection. All indicators are .001" resolution, but higher resolution indicators are available for some models.

Model	Description	Range	Model	Description	Range
ET-7001	External Taper, ½" travel	0" - 6"	ET-7005	External Taper, 1" travel	0" - 16"
ET-7002	External Taper, ½" travel	0" - 10"	ET-7006	External Taper, ½" travel	16" - 24"
ET-7003	External Taper, 1" travel	0" - 10"	ET-7007	External Taper, 1" travel	16" - 24"
ET-7004	External Taper, ½" travel	0" - 16"			

Internal Taper Gages

Gagemaker's internal taper gages measure variation in connection taper. Taper gages are shipped with our standard set of .072" diameter contact points (T072), unless specified otherwise. Refer to the contact point page 124 for the proper contact points for your particular connections. IT-6001 includes one set of extension rods up to 13¾". Higher resolution indicators are available.

Model	Description	Range	Travel	Resolution
IT-6000	Internal Taper Gage	4¼" Depth, 1½" - 9" Diameter	1"	.001"
IT-6001	Internal Taper Gage	Any Depth, 5" - 13¾" API Sizes	½"	.001"
IT-6001-VM	Internal Taper Gage	Any Depth, 3½" Diameter	¼"	.001"

IT-6000 Replacement Parts

Model	Description	Length
IT-6000-07	Replacement Arm Set	4¼"

IT-6001 Replacement Parts (Extensions have #10-40 threads)

Model	Description	Length	Model	Description	Length
IT-6001-01M	Cap- Mitutoyo Indicator	-	IT-6001-13	Extension rod, 9⅝" Connection	4.643"
IT-6001-04	Point Adapter	.062"	IT-6001-14	Extension rod, 10¾" Connection	5.768"
IT-6001-06	Extension rod, 5" Connection	.200"	IT-6001-15	Extension rod, 11¾" Connection	6.768"
IT-6001-07	Extension rod, 5½" Connection	.523"	IT-6001-16	Extension rod, 13¾" Connection	8.393"
IT-6001-09	Extension rod, 6⅝" Connection	1.643"	IT-6001-17	Extension rod, 16" Connection	11.018"
IT-6001-10	Extension rod, 7" Connection	2.023"	IT-6001-18	Extension rod, 18⅝" Connection	13.643"
IT-6001-11	Extension rod, 7⅝" Connection	2.643"	IT-6001-19	Extension rod, 20" Connection	15.018"
IT-6001-12	Extension rod, 8⅝" Connection	3.643"			

IT-6001-VM Replacement Parts

Model	Description	Minimum Bore
IT-6001-01-VM	Short Cap	3.4275"

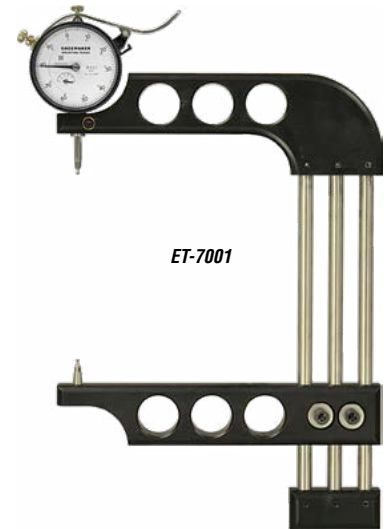

ET-7001



IT-6000

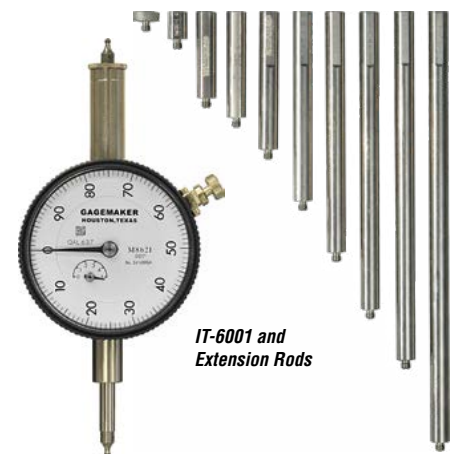

IT-6001 and Extension Rods



Functional Size

External Functional Size Thread Inspection Gages (1/8" to 24" Diameters)

These functional thread inspection, or "GO/NO GO" gages, measure external thread diameters. The gages are adjustable within a size range and use interchangeable thread rolls to measure different pitch threads. Setting dimensions for the functional pitch diameter gages are provided by the TDWIN Thread Disk™ software. **The software (see page 129) and thread rolls (see page 117) are sold separately.** Indicators have a 1/2" travel and .0005" resolution, and higher resolutions are available.

Model	Description	Range
RG-7000	External Thread Roll Gage	3/8" - 4" (15.9 mm - 101.6 mm)
RG-7001	External Thread Roll Gage	4" - 8" (101.6 mm - 203.2 mm)
RG-7002	External Thread Roll Gage	8" - 12" (203.2 mm - 304.8 mm)
RG-7003	External Thread Roll Gage	12" - 16" (304.8 mm - 406.4 mm)
RG-7004	External Thread Roll Gage	16" - 20" (406.4 mm - 508 mm)
RG-7005	External Thread Roll Gage	20" - 24" (508 mm - 609.6 mm)
RG-LAA	Lower Adjustment Arm	

Internal Functional Size Thread Inspection Gages (1 1/2" to 24" Diameters)

Gagemaker also manufactures functional thread inspection gages that inspect internal threads. The gages are adjustable within a size range and use interchangeable thread rolls to measure different pitch threads. Indicators have a 1/2" travel and .0005" resolution, and higher resolutions are available. **Thread roll sets not included.** See page 117 for thread rolls.

Model	Description	Range
PG-6000	Internal Thread Roll Gage, 2 1/2" reach	1 1/2" - 9" (38 mm - 228.6 mm)
PG-6001	Internal Thread Roll Gage, 2 1/2" reach	9" - 16" (228.6 mm - 406.4 mm)
PG-6002	Internal Thread Roll Gage, 2 1/2" reach	16" - 24" (406.4 mm - 609.6 mm)
PG-6003	Internal Thread Roll Gage, 2 1/2" reach	24" - 32" (609.6 mm - 812.8 mm)
PG-6000-SA	Replacement Arm Set	2 1/2" reach
PG-6000-XA	Extended Reach Arm Set	4 1/2" reach
PG-6000-17	Locking T-nut for Arms	

Deep Bore Internal Functional Size

The DPG-6000 gage inspects diameters of internal threads using thread rolls. This functional diameter gage inspects the effects of all thread element variations and reports any deviations. Available in three different sizes, 12", 18", and 24". Custom sizing may be available. **All thread rolls are sold separately.** See page 117 for thread rolls.

Model	Description	Range
DPG-6500	Deep bore thread roll gage assembly for 4 pitch and finer threads only. Includes DPG -A1 Extension Arm	2.970" - 4.400" dia.
DPG-A1	Diameter Extension Arms	2.970" to 4.400" dia.
DPG-A2	Diameter Extension Arms	4.225" to 5.150" dia.
DPG-A3	Diameter Extension Arms	5.025" to 5.950" dia.
DPG-A4	Diameter Extension Arms	5.825" to 6.750" dia.
DPG-A5	Diameter Extension Arms	6.625" to 7.550" dia.
DPG-A6	Diameter Extension Arms	7.425" to 8.350" dia.
DPG-A7	Diameter Extension Arms	8.225" to 9.150" dia.
DPG-A8	Diameter Extension Arms	9.025" to 9.950" dia.
DPG-A9	Diameter Extension Arms	9.825" to 10.750" dia.
DPG-A10	Diameter Extension Arms	10.625" to 11.550" dia.
DPG-A11	Diameter Extension Arms	11.425" to 12.350" dia.



Thread Rolls

Gagemaker thread rolls are sold in matched sets of two rolls. Specify the pitch of the thread when ordering.

UN Series Thread Rolls

"TRV" thread rolls inspect the functional fit of machine threaded parts with 60° "V" thread forms. These thread rolls are designed specifically for internal or external applications.

Internal Thread Diameters (1½" & Larger)		External Thread Diameters (1½" & Larger)	
Model	Description	Model	Description
TRVI-4P	4 pitch internal 60° "V"	TRVE-4P	4 pitch external 60° "V"
TRVI-5P	5 pitch internal 60° "V"	TRVE-5P	5 pitch external 60° "V"
TRVI-6P	6 pitch internal 60° "V"	TRVE-6P	6 pitch external 60° "V"
TRVI-8P	8 pitch internal 60° "V"	TRVE-8P	8 pitch external 60° "V"
TRVI-10P	10 pitch internal 60° "V"	TRVE-10P	10 pitch external 60° "V"
TRVI-12P	12 pitch internal 60° "V"	TRVE-12P	12 pitch external 60° "V"
TRVI-14P	14 pitch internal 60° "V"	TRVE-14P	14 pitch external 60° "V"
TRVI-16P	16 pitch internal 60° "V"	TRVE-16P	16 pitch external 60° "V"
TRVI-18P	18 pitch internal 60° "V"	TRVE-18P	18 pitch external 60° "V"
TRVI-20P	20 pitch internal 60° "V"	TRVE-20P	20 pitch external 60° "V"



Acme and Stub Acme Thread Rolls

"TRA" and "TRSA" thread rolls inspect the functional fit of parts with 29° Acme and Stub Acme thread forms.

Acme Thread Diameters (1½" & Larger)		Stub Acme Thread Diameters (1½" & Larger)	
Model	Description	Model	Description
TRA-2P	2 pitch 29° Acme	TRSA-2P	2 pitch 29° Stub Acme
TRA-3P	3 pitch 29° Acme	TRSA-3P	3 pitch 29° Stub Acme
TRA-4P	4 pitch 29° Acme	TRSA-4P	4 pitch 29° Stub Acme
TRA-5P	5 pitch 29° Acme	TRSA-5P	5 pitch 29° Stub Acme
TRA-6P	6 pitch 29° Acme	TRSA-6P	6 pitch 29° Stub Acme
TRA-8P	8 pitch 29° Acme	TRSA-8P	8 pitch 29° Stub Acme
TRA-10P	10 pitch 29° Acme	TRSA-10P	10 pitch 29° Stub Acme
TRA-12P	12 pitch 29° Acme	TRSA-12P	12 pitch 29° Stub Acme
TRA-14P	14 pitch 29° Acme	TRSA-14P	14 pitch 29° Stub Acme
TRA-16P	16 pitch 29° Acme	TRSA-16P	16 pitch 29° Stub Acme
TRA-18P	18 pitch 29° Acme	TRSA-18P	18 pitch 29° Stub Acme



ISO Metric Series Thread Rolls

"TRM" thread rolls inspect the functional fit of machine threaded parts with ISO Metric 60° "V" thread forms.

Internal Thread Diameters (38.1mm & Larger)		External Thread Diameters (38.1mm & Larger)	
Model	Description	Model	Description
TRMI-4P	4 mm pitch internal 60° "V"	TRME-4P	4 mm pitch external 60° "V"
TRMI-3.5P	3.5 mm pitch internal 60° "V"	TRME-3.5P	3.5 mm pitch external 60° "V"
TRMI-3P	3 mm pitch internal 60° "V"	TRME-3P	3 mm pitch external 60° "V"
TRMI-2.5P	2.5 mm pitch internal 60° "V"	TRME-2.5P	2.5 mm pitch external 60° "V"
TRMI-2P	2 mm pitch internal 60° "V"	TRME-2P	2 mm pitch external 60° "V"
TRMI-1.75P	1.75 mm pitch internal 60° "V"	TRME-1.75P	1.75 mm pitch external 60° "V"
TRMI-1.5P	1.5 mm pitch internal 60° "V"	TRME-1.5P	1.5 mm pitch external 60° "V"
		TRME-1P	1 mm pitch external 60° "V"

National 7° X 45° Buttress Series Thread Rolls

"TRB" thread rolls inspect the functional fit of machine threaded parts with 7° X 45° Buttress thread forms.

Thread Diameter (1½" & Larger)			
Model	Description	Model	Description
TRB745-2P	2 pitch 7° X 45° Buttress	TRB745-8P	8 pitch 7° X 45° Buttress
TRB745-3P	3 pitch 7° X 45° Buttress	TRB745-10P	10 pitch 7° X 45° Buttress
TRB745-3.5P	3.5 pitch 7° X 45° Buttress	TRB745-12P	12 pitch 7° X 45° Buttress
TRB745-4P	4 pitch 7° X 45° Buttress	TRB745-16P	16 pitch 7° X 45° Buttress
TRB745-6P	6 pitch 7° X 45° Buttress		

Trapezoidal Thread Rolls

"TRT" thread rolls inspect the functional fit of machine thread parts with trapezoidal thread forms.

Thread Diameter (38.1 mm & Larger)					
Model	Description	Model	Description	Model	Description
TRT-2P	2 mm pitch Trapezoidal	TRT-5P	5 mm pitch Trapezoidal	TRT-9P	9 mm pitch Trapezoidal
TRT-3P	3 mm pitch Trapezoidal	TRT-6P	6 mm pitch Trapezoidal	TRT-10P	10 mm pitch Trapezoidal
TRT-4P	4 mm pitch Trapezoidal	TRT-8P	8 mm pitch Trapezoidal	TRT-12P	12 mm pitch Trapezoidal

Specials- All other thread forms- Available

Prices Available Upon Request





Small Diameters

Small Internal Diameter Thread Inspection Gages $\frac{5}{8}$ " (.625) to 1½" (1.500) Diameters

SPG-6000 with
thread rolls



The SPG-6000 line of thread inspection gages measures internal thread diameters smaller than 1.500". The SPG-6000 can be equipped with either thread rolls or contact points. Contact points are used to measure pitch diameter, while thread rolls are used in measuring functional size. **Contact points, contact point arms, software, and thread rolls sold separately.**

Model	Description	Range
SPG-6000	Internal Pitch Diameter Gage, 1" reach	$\frac{5}{8}$ " - 1½" (15.9 mm - 38.1 mm)

Small Internal Diameter UN Series Thread Rolls

"SRV" thread rolls inspect the internal functional size of machine threaded parts with 60° "V" thread forms. These thread rolls are designed specifically for internal applications. Rolls are sold in matched sets (2 rolls). **Rolls sold separately from gages and software. Please specify the pitch of thread when ordering.**

Internal Thread Diameters (.750" to 1.500")			
Model	Pitch	Model	Pitch
SRVI-6P	6 pitch internal 60° "V"	SRVI-14P	14 pitch internal 60° "V"
SRVI-7P	7 pitch internal 60° "V"	SRVI-16P	16 pitch internal 60° "V"
SRVI-8P	8 pitch internal 60° "V"	SRVI-18P	18 pitch internal 60° "V"
SRVI-9P	9 pitch internal 60° "V"	SRVI-20P	20 pitch internal 60° "V"
SRVI-10P	10 pitch internal 60° "V"	SRVI-24P	24 pitch internal 60° "V"
SRVI-11P	11 pitch internal 60° "V"	SRVI-28P	28 pitch internal 60° "V"
SRVI-12P	12 pitch internal 60° "V"	SRVI-32P	32 pitch internal 60° "V"
SRVI-13P	13 pitch internal 60° "V"		

Small Internal Diameter ISO Metric Thread Rolls

"SRM" thread rolls inspect the internal functional size of machine threaded parts with 60° "V" thread forms. These thread rolls are designed specifically for internal applications. Rolls are sold in matched sets (2 rolls). **Rolls sold separately from gages and software. Please specify the pitch of thread when ordering.**



SPG Thread Rolls

Internal Thread Diameters (.750" to 1.500")	
Model	Pitch
SRMI-4P	4 mm
SRMI-35P	3.5 mm
SRMI-3P	3 mm
SRMI-25P	2.5 mm
SRMI-2P	2 mm
SRMI-175P	1.75 mm
SRMI-15P	1.5 mm
SRMI-1P	1 mm

Small Diameter Contact Point Arms

“SPA” contact point arms hold “SP” straight shank contact points on the SPG-6000 for small internal pitch diameter measurements. Sold separately from gage as a set of 2. Contact points are not included, see chart below. Custom sizes are available, contact customer service for more information.

SPG-6000 with contact points

Model	Description	Reach	Min. Bore
SPA-265	Contact point arms, .265" Diameter	1" Long	.700"
SPA-375	Contact point arms, .375" Diameter	1.25" Long	.950"
SPA-437	Contact point arms, .437" Diameter	1.50" Long	1.100"

Small Diameter Contact Points

Gagemaker’s SP straight shank contact points are manufactured with carbide balls. Standard contact diameters are held to tolerances of $\pm .0002$. “SP” contact points fit “SPA” contact point arms only. Contact point sizes are matched closely to thread inspection wire sizes. These contact point sizes are used in the TDWIN™ software program (sold separately). Contact points sold individually and separately. Contact point arms are not included.

UN, UNJ, and UNR Series Contact Points

Model	Thread Pitch	Model	Thread Pitch
SP-105	5 pitch	SP-050	11.5 - 12 pitch
SP-096	6 - 7 pitch	SP-041	13 - 16 pitch
SP-072	8 - 9 pitch	SP-032	18 - 20 pitch
SP-057	10 pitch		

Acme, Stub Acme, and Stub Acme Mod-1 & -2 Contact Points

Model	Thread Pitch	Model	Thread Pitch
SP-105T	5 pitch	SP-050T	10 pitch
SP-090T	6 pitch	SP-041T	12 - 14 pitch
SP-062T	8 pitch	SP-032T	16 pitch

Metric and MJ Series Contact Points

Model	Thread Pitch	Model	Thread Pitch
SP-105	4.5 - 4.75 mm	SP-057	2.5 mm
SP-096	4 - 4.25 mm	SP-041	1.5 - 2 mm
SP-072	3 - 3.5 mm	SP-032	1 - 1.25 mm

Small Diameter Contact Point Arms for Threaded Contact Points

“STPA” contact point arms hold threaded contact points on the SPG-6000 for small internal pitch diameter measurements. Sold as a set of 2. Gage, software, and contact points are not included. For contact points, see pages 124-125. Custom sizes are available, contact customer service for more information.

Model	Description	Reach	Min. Bore
STPA-375	Threaded contact point arms, .375" Diameter	1.25" Long	1.032"
STPA-437	Threaded contact point arms, .437" Diameter	1.50" Long	1.152"



SPA Contact Point Arms



SPA Contact Points



STPA Contact Point Arms



Thread Lead

Lead Gages

The lead gage inspects thread leads using contact points that seat in the threads of a part. Thread lead is the distance between threads, measured on a plane parallel to the centerline of the threaded part. The pitch of the thread determines the diameter of the contact points required for taking measurements. API Specification 7-2 requires thread lead inspection.

The **LG-6001** and the **LG-6002** use a two-point system to inspect thread lead for straight and tapered threads. The **LG-6002** inspects both external and internal threads, while the **LG-6001** inspects external threads. The two point system allows for a sweeping action to obtain the measurement.

The **LG-5003** uses the three-point system to inspect internal and external thread lead. Two fixed contact points at the rear of the gage and one moveable contact point at the front of the gage provide complete stability when taking thread lead measurements. This unique design does not require sweeping to obtain measurements.

Contact points can be easily changed to allow the gage to be used on a variety of thread forms.

Before inspecting parts, the lead gage must be preset to a nominal predetermined dimension using a lead gage setting standard. Lead standards are available for both straight and tapered threads. Our setting standards are manufactured according to ANSI and API specifications, respectively.

Please see pages 124-125 for contact points. See page 121 for standards.

Features

- Uses a three-point system for greater stability when inspecting parts (LG-5003).
- Uses interchangeable contact points to allow inspection on a variety of thread forms.
- Requires presetting using Gagemaker's lead gage setting standards.



Model	Description	Minimum Bore	Range
LG-6001	External Lead Gage 2-point	1.200	1/2" - 2" Thread Length
LG-6001-1	External Lead Gage 2-point, .0001" grad. indicator	1.200	1/2" - 2" Thread Length
LG-6002	Lead Gage 2-point	1.200	1/2" - 4" Thread Length
LG-6002-1	Lead Gage 2-point, .0001" grad. indicator	1.200	1/2" - 4" Thread Length
LG-5003	Lead Gage 3-point Contact point spacing .500"	1.340	1/2" - 4" Thread Length
LG-5003-1	Lead Gage 3-point, .0001" grad. indicator, Contact point spacing .500"	1.340	1/2" - 4" Thread Length
LG-5003-J	Lead Gage 3-point, Contact point spacing .193"	1.340	1/2" - 4" Thread Length
LG-5003-1J	Lead Gage 3-point, .0001" grad., Contact point spacing .193"	1.340	1/2" - 4" Thread Length
LG-5003-L	Special Load-to-Load lead gage	1.500	1/2" - 4" Thread Length
LG-5003-S	Special Stab-to-Stab lead gage	1.500	1/2" - 4" Thread Length

Lead Gage Setting Standards

Gagemaker's precision lead gage setting standards are manufactured in accordance with ANSI Specifications, API Specification 5B, and API Specification 7-2. Lead gage standards are used to set the gage prior to inspection.

Model	Connection Type/Description	TPF*	TPI*
LS-1001	API 8-Round Casing, Tubing & Drill Pipe, All 10-Round Tubing	3/4"	8 & 10
LS-1002	Straight Threads, 6 - 18 Pitch, 4" Length	Straight	8 & 10
LS-1003	11 1/2 TPI "V" API Line Pipe	3/4"	11 1/2
LS-1004	Straight threads, Line pipe	Straight	11 1/2
LS-1005	API Buttress Casing, Internal/External 4 1/2" - 13 3/8"	3/4"	5
LS-1006	API Buttress Casing, Internal/External 16" - Larger	1"	5
LS-1007	6 5/8" API Reg 4", 5 1/2", & 6 5/8" API Full Hole 2 7/8", 3 1/2" - 5" Hughes Xtra Hole 2 3/8", 2 7/8" - 4 1/2" Hughes Slim Hole 2 3/8" - 5 1/2" API INT Flush API Numbered Connections #23-#50	2"	4
LS-1008	5 1/2", 7 5/8" - 8 5/8" API Reg API Numbered Connections #56 - #77	3"	4
LS-1009	2 3/8" - 4 1/2" API Reg 3 1/2", 4 1/2" API Full Hole	3"	5
LS-1010	API Numbered Connections #10, #12, #13, #16 M.T. (Macaroni Tubing) 2 3/8" - 3 1/2" PAC 2 3/8" - 4" American Open Hole	1 1/2"	4
LS-1011	3 1/2" - 6 5/8" Hughes H-90	2"	3 1/2
LS-1012	7" - 8 5/8" Hughes H-90	3"	3 1/2
LS-1013	2 3/8" - 3 1/2" Slim Line H-90	1 1/4"	3
LS-5001	Straight Threads, 1-5 pitch, 4" length		
LS-5002	Straight Threads, 6-18 pitch, 4" length		

*TPF = Taper Per Foot, TPI = Threads Per Inch



LS-1005



LS-5001



LS-5002

Lead is measured in one inch intervals. As shown below, the cumulative lead interval is the total measured distance from the first to the last thread.

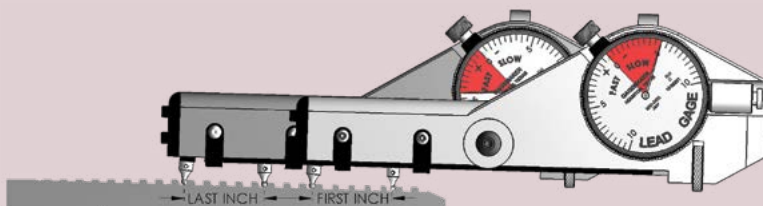

LG-5002 in Last and First Position

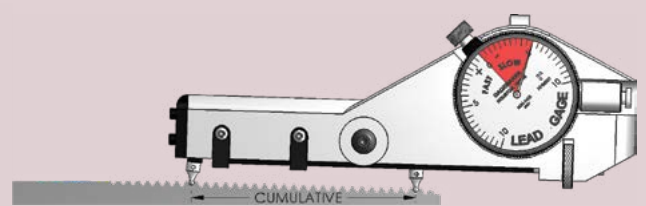

Cumulative



Thread Height

External Thread Height Gages

Gagemaker manufactures many models of external thread height gages. Specify the type of thread when ordering. **Contact point listed in description (e.g. T072) is included, but may specify other.** See page 123 for standards and contact points.



TH-3001V



TH-3001R

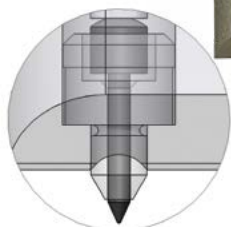

TH-3002B

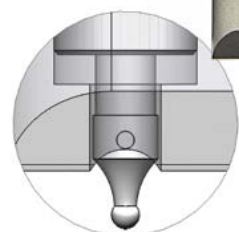

Model	Description	Connection	Travel	Min. Bore
TH-3002B*	External Thread Height, 0-25-0, T072	3/4" TPF Buttress	.094"	2.930"
TH-3003B*	External Thread Height, 0-25-0, Step Base, T072	1" TPF Buttress	.094"	2.930"
TH-3002BB	External Thread Height Base Only	3/4" TPF Buttress		
TH-3003BB	External Thread Height Base Only	1" TPF Buttress		
TH-3001R	External Thread Height, 0-100, T501	8-Round	.162"	3.400"
TH-3002R*	External Thread Height, 0-50-0, T501	8-Round	.162"	3.400"
TH-3002RB	External Thread Height Base Only	8-Round		
TH-3000-RSC*	External Thread Height, 0-25-0, T072**	Rotary Shouldered Connection/Tool Joint	.196"	3.230"
TH-3001S	External Thread Height, 0-100, T072	8-Round	.196"	3.230"
TH-3001V	External Thread Height, 0-100, T500C	Line Pipe, UN/UNJ/UNR, Acme, Stub Acme Modified I and II, Metric M & MJ, 7° X 45° Buttress, General Purpose Pipe Threads	.196"	3.230"
TH-3002V*	External Thread Height, 0-50-0, T500C	Line Pipe/Tool Joint	.196"	3.230"
TH-3002VB	External Thread Height Base Only	Line Pipe/Tool Joint		

***Gage requires a standard for setting before inspection.**

****Also ships with either T034 or T044 depending on the connection, please specify when ordering.**

Internal Thread Height Gages

Gagemaker also manufactures several models of internal thread height gages. Please specify the type of thread when ordering. **Contact point listed in description (e.g. T072) is included, but may specify other.** See page 123 for standards and contact points.

Model	Description	Connection	Travel	Min. Bore
TH-3004*	Internal Thread Height, 0-25-0, T500C	Line Pipe	.105"	1.575"
TH-3006*	Internal Thread Height, 0-25-0, T502/T503	8-Round	.105"	1.595"
TH-3008*	Internal Thread Height, 0-25-0, T502/T503	8-Round	.094"	1.575"
TH-3009*	Internal Thread Height, 0-25-0, T072	3/4" TPF Buttress	.250"	1.750"
TH-3009-RSC*	Internal Thread Height, 0-25-0, 1" Base, T072**	Rotary Shouldered Connections	.250"	1.750"
TH-3010	Internal Thread Height, 0-100, 1" Base Length (TPD), T500	Line Pipe, UN/UNJ/UNR, Acme, Stub Acme, Stub Acme Modified I and II, Metric M & MJ, 7° X 45° Buttress, General Purpose Pipe Threads	.250"	1.750"
TH-3012*	Internal Thread Height, 0-25-0	3/4" - 2" NPT, AMT	.090"	.750"

***Gage requires a standard for setting before inspection.**

****Also ships with either T034 or T044 depending on the connection, please specify when ordering.**

Thread Height Gage Standards

Gagemaker manufactures precision setting standards for presetting thread height gages. Please specify the type of thread when ordering. Custom or special standards are available, contact customer service for more information.

Model	Description
THS-1014	8 & 10 Round Threads
THS-1014S	8 & 10 Round Threads (crest to Pitchline "Shave")
THS-1015	8 & 11½ Pitch "V" Threads
THS-1017	13¾" & Smaller Buttress, ¾" TPF
THS-1018	16" & Larger Buttress, 1" TPF
THS-10322	V-0.032, 2 TPF Rotary Shouldered Connections, 6 TPI to be used with T034 pt.
THS-10382	V-0.038R, 2 TPF Rotary Shouldered Connections, 4 TPI to be used with T072 pt.
THS-10383	V-0.038R, 3 TPF Rotary Shouldered Connections, 4 TPI to be used with T072 pt.
THS-10403	V-0.040, 3 TPF Rotary Shouldered Connections, 5 TPI to be used with T034 pt.
THS-10502	V-0.050, 2 TPF Rotary Shouldered Connections, 4 TPI to be used with T044 pt.
THS-10503	V-0.050, 3 TPF Rotary Shouldered Connections, 4 TPI to be used with T044 pt.
THS-10551.5	V-0.055, 1.5 TPF Rotary Shouldered Connections, 6 TPI to be used with T072 pt.
THS-10761.5	V-0.076, 1.5 TPF Rotary Shouldered Connections, 4 TPI to be used with T044 pt.
THS-10H90-2	2" TPF H-90 Connection (90-V-0.050), 3.5 TPI to be used with T072 pt.
THS-10H90-3	3" TPF H-90 Connection (90-V-0.050), 3.5 TPI to be used with T072 pt.
THS-SL-H90	1¼" TPF, 3 TPI, 90-V-0.084 to be used with T072 pt.

Thread Height Gage Contact Points

Model	Description
T072	0.072" Contact Point for Buttress Threads, RSC Thread Forms V-0.038R & V-0.055
T044	0.044" Contact Point Rotary Shouldered Connection V-0.050 and V-0.076 thread forms
T034	0.034" Contact Point Rotary Shouldered Connection V-0.032 and V-0.040 thread forms
T500C	50° Cone Contact Point, "V" Threads for TH-3001V, TH-3002V, & and TH-3004 Gages
T500C-USS	Modified 50° Cone Contact Point, USS Improved Buttress
T501	50° Cone Contact Point, Self-Centering for TH-3001R and TH-3002R Gages
T502	Self-Centering Sleeve for T501 & T503 Contact Points
T503	50° Cone Contact Point, "V" Threads for TH-3006
E-Line	.063" R Extreme Line Contact Point





Contact Points

API Contact Points for Lead and Taper Gages

Gagemaker's standard contact points are manufactured with carbide balls. Both threaded and straight (non-threaded) shanks are available. All Gagemaker's inspection gages use threaded shank contact points. Threaded shanks are #4-48 UNF. Metric threads are available upon request. Most gages require two contact points.

Straight Shank Model	Threaded Shank Model	Point Diameter	Threads Per Inch	Connection Type
S235	T235	0.235"	3	Hughes Slim Line H-90
S200	T200	0.200"	3½	All Hughes H-90
S144	T144	0.144"	4	API Rotary Shouldered Connections
S128	T128	0.128"	4½	API Rotary Shouldered Connections
S115	T115	0.115"	5	API Rotary Shouldered Connections
S105T	T105T	0.105"	5½	Truncated for Extreme Line
S096	T096	0.096"	6	API Rotary Shouldered Connections
S090	T090	0.090"	5	Buttress Casing – Taper
S072	T072	0.072"	8	API Tubing and Casing
S062	T062	0.062"	5	Buttress Casing – Lead
S057	T057	0.057"	10	API Tubing and Line Pipe
S050	T050	0.050"	11½	API Line Pipe
-	T044	0.044"	4	RSC Thread Depth Only
S041	T041	0.041"	14	API Line Pipe
-	T034	0.034"	5	RSC Thread Depth Only
S032	T032	0.032"	18	API Line Pipe
S021	T021	0.021"	27	API Line Pipe

Special Application Contact Points

Gagemaker continually develops new application contacts and indicator accessories. The following items are in stock for immediate delivery. These contact points have #4-48 UNF threaded shank. All contact points are carbide. Special and metric diameters are available, please call for quotation. **Straight Shanks are available for T060, T098, and T156.**

Model	Ball Dia.	Model	Ball Dia.	Model	Ball Dia.	Model	Ball Dia.
T028	.028"	T100	.100"	T176	.176"	T375	.375"
T043	.043"	T116	.116"	T188	.188"	T430	.430"
T045	.045"	T118	.118"	T219	.219"	T4375	.4375"
T059	.059"	T125	.125"	T250	.250"	T475	.475"
T060	.060"	T1335	.1335"	T266	.266"	T500	.500"
T068	.068"	T150	.150"	T295	.295"	T531	.531"
T071	.071"	T155	.155"	T300	.300"	T625	.625"
T086	.086"	T156	.156"	T325	.325"	T750	.750"
T087	.087"	T157	.157"	T344	.344"		
T092	.092"	T160	.160"	T350	.350"		
T098	.098"	T165	.165"	T360	.360"		

General Purpose Points and Accessories

Model	Description
T500C	50° Cone Contact Point, "V" Threads for TH-3001V, TH-3002V, TH-3004 Gages
T500C-USS	Modified 50° Cone Contact Point, USS Improved Buttress
T501	50° Cone Contact Point, Self-Centering for TH-3001R, TH-3002R Gages
T502	Self-Centering Sleeve for T501 & T503 Contact Points
T503	50° Cone Contact Point, "V" Threads for TH-3006
E-Line	.063" R Extreme Line Contact Point
TPD	.005" R Contact Point for PD-3003 & PD-3004 Gages
PE-	Point Extensions available in .300", .500", .750" & 1.00" (Ex. PE-300)
PA-45	45° Point Adapter, contact point not included
RC-375	.375" Diameter Roller Contact
P-500	TH-3001R Gage, Flat Face Contact
Blade-25	.008" thickness, .170" Diameter, .250" Depth Blade Point
Blade-50	.008" thickness, .170" Diameter, .500" Depth Blade Point

Straight Shank Contact Points



T501 and T502 Assembly



T501

T503

T502

PA-45 with contact point (sold separately)

RC-375

T500C

E-Line

Blade

TPD

T500C-USS

P500

Point Extensions (Left to Right: PE-.300, PE-.500, PE-.750, PE-1.00)



Contact Points(Continued)

UN Series (60° “V”) Threads

These contacts points are used to inspect the pitch diameter of machined parts with 60° “V” thread forms. Two are required for most gages.

Model	Thread Pitch	Model	Thread Pitch	Model	Thread Pitch
T562	1	T115	5	T050	11½ & 12
T288	2	T105	5½	T041	14 & 16
T188	3 & 3½	T096	6	T032	18
T144	4	T072	8		
T128	4½	T057	10		



Truncated Contact Point

Acme or Stub Acme Threads

These truncated contact points are used to inspect the pitch diameter of machined parts with 29° Acme and Stub Acme thread forms. Two are required for most gages.

Model	Thread Pitch	Model	Thread Pitch	Model	Thread Pitch
T531T	1	T144T	3½	T050T	10
T344T	1½	T128T	4	T041T	12 & 14
T266T	2	T105T	5	T032T	16
T219T	2½	T090T	6 & 7		
T188T	3	T062T	8		

Threaded Shank Contact Points



T041



T062



T072



T105



T115



T125



T250

7° x 45° Buttress Series Contact Points

These contact points are used to inspect the pitch diameter of machined parts with 7° x 45° Buttress thread forms. Two are required for most gages.

Model	Thread Pitch	Model	Thread Pitch	Model	Thread Pitch
T562	1	T188	3	T072	8
T437	1¼	T156	3½	T057	10
T375	1½	T144	4	T050	12
T281	2	T115	5	T032	16 & 18
T219	2½	T096	6		

Trapezoidal Thread Contact Points

These contact points are used to inspect the millimeter pitch diameter of machined parts with Trapezoidal thread forms. Two are required for most gages.

Model	mm Pitch	Model	mm Pitch
T144	7	T062	3
T125	6	T050	2½
T096	5	T041	2
T082	4	T032	1½
T072	3½		

ISO Metric Series Contact Points

These contact points are used to inspect the pitch diameter of machined parts with ISO Metric 60° “V” thread forms. Two are required for most gages.

Model	mm Pitch	Model	mm Pitch
T096	4	T057	2½
T072	3 & 3½	T041	1½, 1¾, & 2



Thread Form

Straight Thread Form Profile Gages

Gagemaker manufactures precision straight thread profile gages for quick identification of a thread form. **Specify thread pitch to be inspected when ordering.** Special form profiles are available.

Model	Description
TP-UNVI-__P	Internal UN series thread gage
TP-UNVE-__P	External UN series thread gage
TP-GPA-__P	Internal/external general purpose Acme thread profile gage
TP-SA-__P	Internal/external Stub Acme thread profile gage
TP-SAM1-__P	Modified 1 Stub Acme thread profile gage
TP-SAM2-__P	Modified 2 Stub Acme thread profile gage
TP-MI-__P	Internal ISO Metric series thread profile gage
TP-ME-__P	External ISO Metric series thread profile gage
TP-745-__P	Internal/External 7° X 45° Buttress thread profile gage

Order Example

TP-UNVI-2P,
TP-UNVE-4P,
TP-SA-8P, etc.

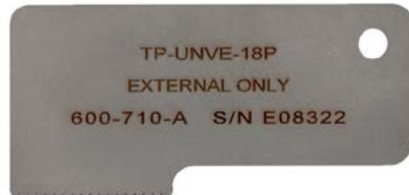
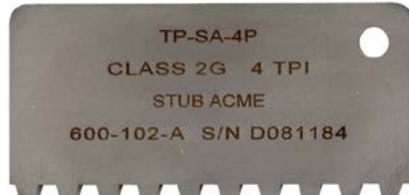
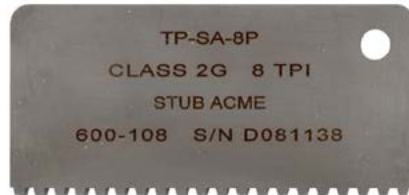

Assorted Straight Thread Profiles



Assorted Tapered Thread Profiles



Tapered Thread Form Profile Gages

Gagemaker manufactures precision tapered thread profile gages for the quick identification thread form identification. When ordering, specify the connection to be inspected. Special profiles will be quoted upon request.

Model	Connection Type	TPI, TPF, Thread Form
TP-RTC-8R	API 8-Round Casing, Tubing & Drill Pipe	8 TPI, 3/4" TPF, 8 Round
TP-RTC-10R	API 10-Round Tubing	10 TPI, 3/4" TPF, 10 Round
TP-8V	8V API Line Pipe	8 TPI, 3/4" TPF, 8 V Thread
TP-11-1/2V	11 1/2 V API Line Pipe	11 1/2 TPI, 3/4" TPF, 11 1/2 V Thread
TP-5BTC75-INT	API Buttress Casing, Internal, 4 1/2" - 13 3/4"	5 TPI, 3/4" TPF
TP-5BTC75-EXT	API Buttress Casing, External, 4 1/2" - 13 3/4"	5 TPI, 3/4" TPF
TP-5BTC1-INT	API Buttress Casing, Internal, 16" - 20"	5 TPI, 1" TPF
TP-5BTC1-EXT	API Buttress Casing, External, 16" - 20"	5 TPI, 1" TPF
TP-3-1.25-84	2 3/8" - 3 1/2" Hughes Slimline H-90	3 TPI, 1.25" TPF, 90-V-0.084
TP-3.5-2-50	3 1/2" - 6 5/8" Hughes H-90	3.5 TPI, 2" TPF, 90-V-0.050
TP-3.5-3-50	7" - 8 5/8" Hughes H-90	3.5 TPI, 3" TPF, 90-V-0.050
TP-4-1.5-76	2 3/8" - 3 1/2" P.A.C. Connections 2 3/8" - 4 1/2" American Open Hole	4 TPI, 1.5" TPF, V-0.076
TP-4-2-50	6 5/8" API Regular 5 1/2" & 6 5/8" API Full Hole	4 TPI, 2" TPF, V-0.050
TP-4-2-38	4" API Full Hole, 2 7/8" - 5" Hughes Xtra Hole, 2 3/8" - 4 1/2" Hughes Slim Hole, 2 3/8" - 6 5/8" Internal Flush API Numbered Connections #23 - #50	4 TPI, 2" TPF, V-0.038R
TP-4-3-38	API Numbered Connections #56 - #77	4 TPI, 3" TPF, V-0.038R
TP-4-3-50	5 1/2", 7 5/8", & 8 5/8" API Regular	4 TPI, 3" TPF, V-0.050
TP-5-3-40	2 3/8" - 4 1/2" API Regular 2 7/8", 3 1/2", 4 1/2" API Full Hole	5 TPI, 3" TPF, V-0.040
TP-6-1.5-55	API Numbered Connections #10, #12, #13, #16 M.T. (Macaroni Tubing)	6 TPI, 1.5" TPF, V-0.055
TP-6-2-32	2 3/8" - 2 7/8" Hughes External Flush	6 TPI, 2" TPF, V-0.032
TP-9060LS	90° & 60° Threads, Tool Grinding & Setting Gage	Tool Grinding & Setting Gage
TP-NPT-8	NPT Threads	8 TPI, 3/4" TPF
TP-NPT-11-1/2	NPT Threads	11.5 TPI, 3/4" TPF
TP-NPT-14	NPT Threads	14 TPI, 3/4" TPF

Specials Available Upon Request

Thread Form Profile Overlays

Overlay Charts for profiles are available. For more information, please contact customer service.

Special Overlay are also available. For Special Overlays, please specify the following:

1. Screen Size
2. Magnification 20X/50X
3. Product Form or Profile Template

Buttress Runout

Buttress Runout Gage

Buttress runout gages ensure proper thread pullout on runout type threads. Thread runout is the measurement of the abruptness with which the buttress thread is terminated at the triangle end of the thread. A rapid pull-out of the cutting tool results in steep slope at the end of the thread. This causes high stress at the contact point when the coupling is made-up. Buttress runout gages have standard 1" and 2" point spacing. Includes one contact point (TBR) and shoes.

Model	Description	Range
BR-2001	Buttress Runout Gage	All Sizes
BR-2001-USS	Buttress Runout Gage for USS Improved Buttress	All Sizes
BRB-2001	Buttress Runout Base Only	All Sizes
BRS-2001	Replacement Shoes (2)	



BR-2001

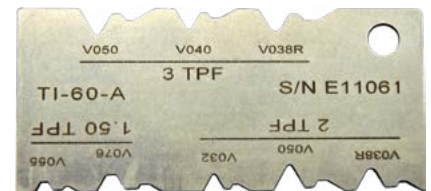

TI-RSC-60

Insert Identification

Insert Identifiers

Gagemaker's thread insert indentifiers easily determine which threading insert the machinist is using. When an optical comparator is unavailable, the insert identifier will show which thread form is on the insert.

Model	Taper Per Foot/Pitch	Thread Forms
TI-RSC-60	1.5", 2", & 3"	Rotary Shouldered Connections- V-0.032, V-0.038R, V-0.040, V-0.050, V-0.055, V-0.065, & V-0.076
TI-RSC-90	1.25", 2", 3", & 3.373"	Rotary Shouldered Connections- A-0.094, 90-V-0.050, & 90-V-0.084
TI-ACME-INT	3P, 3.5P, 4P, 5P, 6P, 8P, 10P, 12P, 14P, & 16P	Internal Acme
TI-SACME-INT	3P, 3.5P, 4P, 5P, 6P, 8P, 10P, 12P, 14P, & 16P	Internal Stub Acme
TI-T&C	¾" and 1"	Tubing and Casing - 8 Round, 10 Round, & ¾" and 1" Internal and External Buttress





TDWIN™ Software

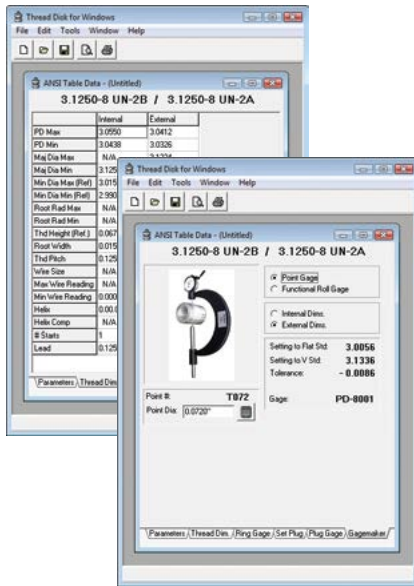

TDWIN™ Screenshots



TDWIN™ Report

Software

Thread Disk™ Software Straight Thread Dimensions

TDWIN™

The Thread Disk™ engineering software calculates critical dimensions for threads based on ANSI tables and formulas. Thread types supported by the program include: UN, UNJ and UNR Series, Acme, Stub Acme, Stub Acme Modified I and II, Metric M & MJ, 7° X 45° Buttress, and General Purpose Pipe Threads.

To generate critical dimensions instantly, enter basic thread information on the Thread Type Entry screen, such as: thread type, thread class, nominal diameter, and threads per inch. Once the results are computed, tabs at the bottom of the program allow selection of several types of calculated information, including dimensions and tolerances for product threads, ring gages, set plugs, plug gages or Gagemaker's Thread Diameter gages.

If measuring internal and external shallow taper diameters is a problem, the Ball Mic SET DIM Tool provides setting dimensions for ball micrometers or Gagemaker's BX-1000 groove gage. The program calculates ball mic settings for any tapered surface geometry.

Other features of the program include the ability to print thread dimension reports, providing a paper copy of any calculation. These reports provide the same critical dimensions that display in the program. A multiple calculation window capability is a feature that allows performing several different thread calculations at the same time.

System Requirements

- Windows XP or higher
- 64 MB RAM
- 3 MB of free hard disk space

Features

- Uses ANSI tables, formulas, and tolerances
- Calculates standard and non-standard product thread diameters from #000 to 99.8"
- Calculates ANSI ring and plug gage dimensions
- Addresses pitches from 1 to 400
- Calculates Gagemaker style thread gage setting dimensions

Model	Description
TDWIN	Thread Disk software
TDWIN-Network	Multi-user license agreement

Thread Disk Software Tapered Thread Dimensions

TDWIN Taper™

Gagemaker's TDWIN Taper™ software simplifies the API specifications that control connection quality. TDWIN Taper™ produces dimensional drawings and inspection data for API downhole tubular connections based on the most current industry standards. All the necessary details to machine, inspect and document tubular connection threads are available in one convenient program.

TDWIN Taper™ provides easy access to information for both preferred and non-preferred Rotary Shouldered Connections, Tubing and Casing Connections, and any combination of Crossover. The program offers standard connection types and sizes. TDWIN Taper™ relies on API and industry standard tables and tolerances. It displays connection drawings, inspection gage information, and setup and inspection reports.

The software displays printable drawings suitable for manufacturing. The drawings follow ASME Y14.5 standards for industry compatibility. Print gage setup and inspection reports with your company logo and work order information. The program offers the choice to save reports and jobs for future reference.

Tapered oilfield connection types supported by the program include the following:

Rotary Shouldered Connections

API Numbered Connections
API Regular
Full Hole
Internal Flush
Open Hole

PAC
Slim Hole
Wide Open
Xtra Hole
H-90

Slimline H-90
External Flush
Acme Regular
Acme Streamline
Double Streamline

Tubing and Casing Connections

NUE Tubing
EUE Tubing
Short Thread Casing
Long Thread Casing
Buttress Casing

USS Improved Buttress Tubing
Line Pipe
Special Clearance Couplings
SR13 Seal Ring Groove Couplings

System Requirements

- Microsoft Windows XP or newer
- USB 2.0 port
- Internet Connection for first use
- 1 MB RAM or more (recommended)
- Screen resolution of 1024 x 768 minimum
- .Net Framework 2.0 or later installed

Features

- Print dimensional reports and inspection sheets
- Print product blueprints for manufacturing and inspection
- Provides gages configurations, setting standards, and contact point information

Model	Description
TDWIN-Taper-2.0	Thread Disk Software for Tapered Threads

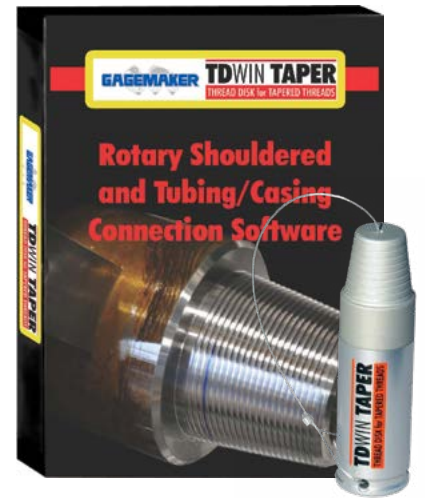

TDWIN Taper Software

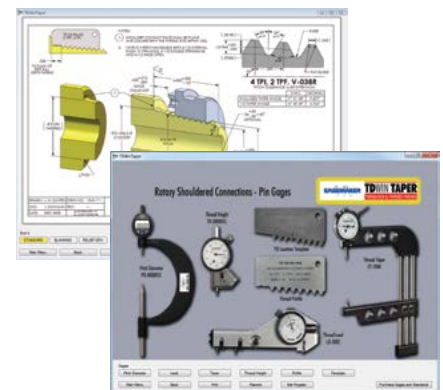

TDWIN Taper™ Screenshots

TDWIN Taper™ Report



Indicators

Dial Indicators

Gagemaker's mechanical indicators are manufactured per ANSI AGD specifications.



Model	Correlating Gage Model	Travel	Resolution
1512SGA (CONT)	WT-9000 Series	.250"	.0005"
1512SRGA (CONT)	TH-3002R, TH-3002V, PD-3003	.250"	.0005"
1513SGA (BAL)	PN-3000 Series, BX-1000, BXG-1000 (was 803)	.250"	.0005"
1513SRGA (BAL)	TH-3002B, TH-3003B, TS-4001 (was 803I)	.125"	.0005"
801 (BAL)	BR-2001	.250"	.001"
801I (BAL)	TH-3002R, TH-3002V	.250"	.001"
802 (CONT)	WT-9000 Series	.250"	.001"
802I (CONT)	TH-3001R, TH-3001V, PD-3003	.250"	.001"
862L (CONT)	ET-7001, ET-7002, ET-7004, ET-7006 Series w/ Lever	.500"	.001"
862I (CONT)	IT-6001, PD-3004	.500"	.001"
863	RG-7000 Series, TH-3004, TH-3006, TH-3008, TH-3009, TH-3010, SRG-7000, CA-9001, MRP-5000 Series, SPG-6000	.500"	.0005"
863L (BAL)	PD-8000 Series w/ Lever	.500"	.0005"
863I (BAL)	PD-6000, PD-6001, PG-6000 Series, TS-1000, IT-5100, MRP-5500, SPG-6000	.500"	.0005"
882L (CONT)	ET-7003, ET-7005, ET-7007 w/ Lever	1.00"	.001"
882I (CONT)	IT-6000	1.00"	.001"
80-0403	LG-5002, LG-5003	.100"	.0005"
80-0400	LG-5002, LG-5003	.025"	.0001"
83-0584	MRP-2000, MRP-2500, MRP-3000	.500"	.001"
83-0582	MRP-2000, MRP-2500, MRP-3000	.500"	.0005"
87-070	MRP-1000, MRP-1500	.125"	.0005"

Notes: (BAL) indicates Balanced.

(CONT) indicates Continuous.

"I" after the model number indicates counter clockwise rotation.

"L" after model number indicates a lifting lever.

Multipurpose Indicators

Model	Description	Travel	Resolution
2358B-MRP	All MRP® Gages	.500"	.0001"
2358SGA	Multipurpose Indicator, Balanced	.500"	.0001"
2358SRGA	Multipurpose Indicator, Balanced	.500"	.0001"
2776SGA	Multipurpose Indicator, Continuous, Clockwise	1.00"	.0005"
2776SRGA	Multipurpose Indicator, Continuous, Counterclockwise	1.00"	.0005"
2777SGA	Multipurpose Indicator, Balanced, Clockwise	1.00"	.0005"
2777SRGA	Multipurpose Indicator, Balanced, Counterclockwise	1.00"	.0005"

Metric Dial Indicators

Model	Description	Travel	Resolution
1044SGA	Metric Mechanical, Continuous, Clockwise	5 mm	.01 mm
1044SRGA	Metric Mechanical, Continuous, Counterclockwise	5 mm	.01 mm
1045SGA	Metric Mechanical, Balanced, Clockwise	5 mm	.01 mm
1045SRGA	Metric Mechanical, Balanced, Clockwise	5 mm	.01 mm
2046SGA	Metric Mechanical, Continuous, Clockwise	10 mm	.01 mm
2047SGA	Metric Mechanical, Balanced, Clockwise	10 mm	.01 mm
2902SRGA	Metric Mechanical, Continuous, Counterclockwise	10 mm	.01 mm
2047SRGA	Metric Mechanical, Balanced, Clockwise	10 mm	.01 mm
2050S-01	Metric Mechanical, Continuous	20 mm	.01 mm

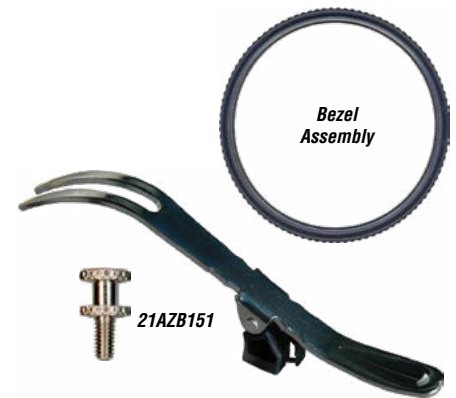

21AZB151

Digital Indicators

Model	Description	Travel	Resolution	Accuracy
543-452B	Electronic/Digital	1"	.00005"	.0005"
543-683B	Electronic/Digital	.500"	.0005"	.0005"



21RZA065

Indicator Replacement Parts

Dial rings are available for all indicators. Please call for more information.

Small Dials

Model	Description
21AZB353	Bezel Assembly (Blue "S" Type)
21BAA147A	Bezel Assembly (Black "F" Type)
21AAB364	Bezel Clamp Washer (Blue "S" Type)
21AAB162	Bezel Clamp Screw (Blue "S" Type)
193592	Bezel Clamp Washer (Black "F" Type)
193690	Bezel Clamp Screw (Black "F" Type)
900527	Mitutoyo Lifting Lever



193592 & 193690

Large Dials

Model	Description
21AZB161	Bezel Assembly (Blue "S" Type)
192683	Bezel Assembly (Black "F" Type)
21RZA065	Bezel Clamp Assembly (Blue "S" Type)
21BA083	Bezel Clamp Washer (Black "F" Type)
101214	Bezel Clamp Screw (Black "F" Type)
21AZB151	Mitutoyo Lifting Lever



SC0232014-00



Gage Setting and Part Measurement

Gage Setting and Part Measurement Systems

This package features the MIC TRAC™ as a multi-use gage setting system. The system sets or zeros most gages with the use of interchangeable anvils or blocks. Standard resolution of base unit is .00005". Accuracies range from ±.0001" to ±.0004". The Digital Read Out (DRO) is CE approved. All MIC TRAC™ 3000 Series include one set of TF-PL blocks and a shipping carton. Larger ranges are available, please contact customer service for more information.

Shop Floor Gage Setting and Part Measurement System



Model	Description	Accuracy	Resolution	Range
<i>MT-3000 Standard Base Units without Force-Lok</i>				
MT-3012-50	MIC TRAC™ Base Unit w/ DRO	±.0001"	.00005"	Int. 0" - 12" Ext. 1½" - 13½"
MT-3024-50	MIC TRAC™ Base Unit w/ DRO	±.0002"	.00005"	Int. 0" - 24" Ext. 1½" - 25½"
MT-3036-50	MIC TRAC™ Base Unit w/ DRO	±.0003"	.00005"	Int. 0" - 36" Ext. 1½" - 37½"
MT-3048-50	MIC TRAC™ Base Unit w/ DRO	±.0004"	.00005"	Int. 0" - 48" Ext. 1½" - 49½"
<i>MT-3000 Standard Base Units with Force-Lok</i>				
MT-3012F-50	MIC TRAC™ Base Unit w/ DRO and Force-Lok	±.0001"	.00005"	Int. 0" - 12" Ext. 1½" - 13½"
MT-3024F-50	MIC TRAC™ Base Unit w/ DRO and Force-Lok	±.0002"	.00005"	Int. 0" - 24" Ext. 1½" - 25½"
MT-3036F-50	MIC TRAC™ Base Unit w/ DRO and Force-Lok	±.0003"	.00005"	Int. 0" - 36" Ext. 1½" - 37½"
MT-3048F-50	MIC TRAC™ Base Unit w/ DRO and Force-Lok	±.0004"	.00005"	Int. 0" - 48" Ext. 1½" - 49½"
<i>MT-3000 Base Unit with Computer & MT-4-USB</i>				
MT-3012F-50-USBC	MIC TRAC™ Base Unit with Force-Lok, Computer, & USB	±.0001"	.00005"	Int. 0" - 12" Ext. 1½" - 13½"
MT-3024F-50-USBC	MIC TRAC™ Base Unit with Force-Lok, Computer, & USB	±.0002"	.00005"	Int. 0" - 24" Ext. 1½" - 25½"
MT-3036F-50-USBC	MIC TRAC™ Base Unit with Force-Lok, Computer, & USB	±.0003"	.00005"	Int. 0" - 36" Ext. 1½" - 37½"
MT-3048F-50-USBC	MIC TRAC™ Base Unit with Force-Lok, Computer, & USB	±.0004"	.00005"	Int. 0" - 48" Ext. 1½" - 49½"
<i>High Resolution MT-3000 Base Unit with Computer & MT-4-USB</i>				
MT-3012F-10-USBC	MIC TRAC™ Base Unit with Force-Lok, Computer, & USB	±.00005"	.00001"	Int. 0" - 12" Ext. 1½" - 13½"
MT-3024F-10-USBC	MIC TRAC™ Base Unit with Force-Lok, Computer, & USB	±.00010"	.00001"	Int. 0" - 24" Ext. 1½" - 25½"
MT-3036F-10-USBC	MIC TRAC™ Base Unit with Force-Lok, Computer, & USB	±.00015"	.00001"	Int. 0" - 36" Ext. 1½" - 37½"
MT-3048F-10-USBC	MIC TRAC™ Base Unit with Force-Lok, Computer, & USB	±.00020"	.00001"	Int. 0" - 48" Ext. 1½" - 49½"
MT-3060F-10-USBC	MIC TRAC™ Base Unit with Force-Lok, Computer, & USB	±.00025"	.00001"	Int. 0" - 60" Ext. 1½" - 61½"

MIC TRAC™ Setting Blocks

The MIC TRAC™ 3000 receiver blocks include precision, calibrated surfaces designed for mounting all the various setting blocks. Depending on the requirements of the application, each pair of MIC TRAC™ setting blocks is precisely ground with either a flat or tapered gauging surface. Setting blocks are supplied in sets of two, with various degrees of taper available.

Model	Description
<i>Shallow Tapered Cylinder Setting Blocks (2 Block Sets) (used with BX-1000 gages)</i>	
TF-10	Tapered Setting Blocks 10° half angle
TF-15	Tapered Setting Blocks 15° half angle
TF-20	Tapered Setting Blocks 20° half angle
TF-30	Tapered Setting Blocks 30° half angle
TF-45	Tapered Setting Blocks 45° half angle
<i>Special Purpose Setting Blocks</i>	
TF-.5F	Flat Face Setting Blocks (1.000" outside diameter)
TF-1F	Universal flat face setting / measuring blocks (1.500" outside diameter)
TF-PL	Flat Face Setting Blocks, No taper (supplied with MIC TRAC™)
<i>API 6A Ring Groove & Special Flange Groove Setting Blocks</i>	
TF-BX	23° BXR Ring Groove Diameter/Width Setting Blocks, used with BX-1000 gages (2 per set)
<i>Thread Gage Setting Blocks</i>	
TF-1V	3-5 pitch 60° "V" thread setting blocks (2 per set)
TF-2V	6-20 pitch 60° "V" thread setting blocks (2 per set)
<i>Tubing and Casing Taper Setting Blocks</i>	
TF-STR	Straight Blocks
TF-.75T	¾" Taper Blocks, 8 & 10 Round, ¾" TPF Buttress, Line Pipe
TF-1.0T	1" Taper Blocks, 1" TPF Buttress
TF-1.12T	1 1/8" Taper Blocks, 1.125 TPF Connection
TF-1.75T	1 3/4" Taper Blocks, 1.75 TPF Connections
Special Taper Blocks Available	
<i>MRP® Straight Face Setting Blocks</i>	
TF-1F-T	Flat face setting blocks to accept riser block (T-Shape)
<i>Riser Blocks for the Taper Blocks</i>	
TF-RISER1	1.00" Riser Block (Set of 2)
TF-RISER2	2.00" Riser Block (Set of 2)
TF-RISER3	3.00" Riser Block (Set of 2)

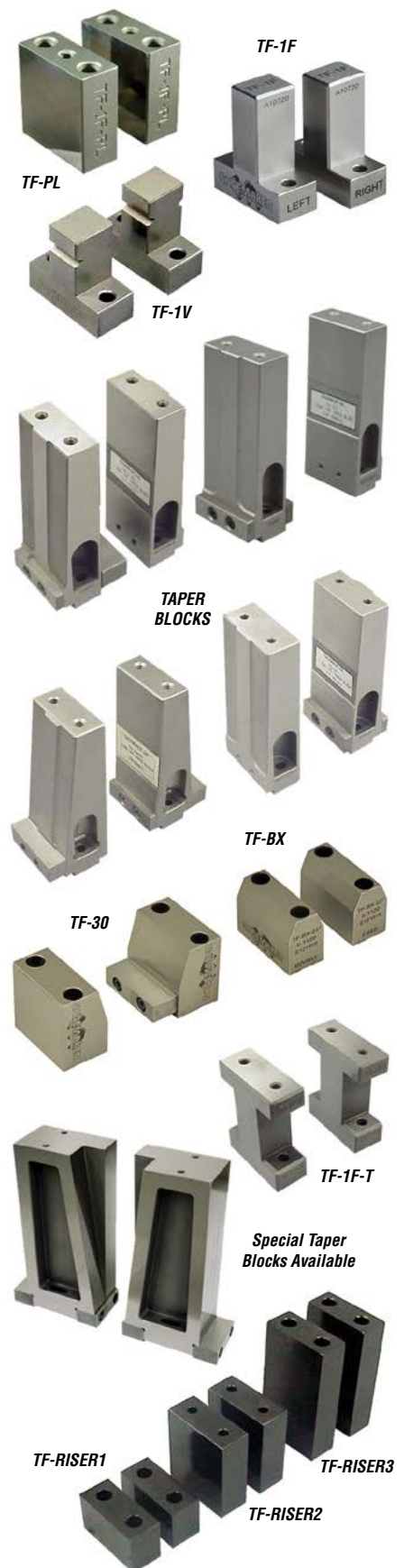



Precision Gage Calibration System

MIC TRAC™ 4000 Package

This package features the MIC TRAC™/MT-4000 as a precision calibration system. The system accepts fixtures that inspect and calibrate a wide range of gage diameters and thread pitches. The package includes all the equipment necessary to calibrate precision handheld gages. Ring and plug inspection requires the purchase of additional accessories.

Package includes:

- MT-4012-10 MIC TRAC™ electronic adjustable measurement master, range 0" to 12". Base unit is error compensated to an accuracy of $\pm 0.00005"$, resolution $.00001"$, travel 12.000".
- Ultra precision scale with 1.00" travel, accuracy $\pm 0.00002"$, and resolution $.00001"$.
- Computer with CERTIFI™ Calibration Software. CERTIFI™ produces calibration reports, has a recall database, and a digital readout acquisition module.
- CRC MT-4000 Calibration Reference Card Set: procedures documenting calibrations with the Gagemaker system
- TF-2R: Carbide anvil set, $\frac{3}{8}"$ diameter
- TF-XYT: Adjustable X, Y & tilt support table for use with the MIC TRAC™
- CAL-PAK: Assortment of fixtures designed to hold gages for calibration
- TDWIN Thread Disk software program: provides critical thread dimensions for manufacturing and inspection of UN, Acme, Stub Acme, Metric, Buttress, and NPT threads.
- Torque wrench, 50 in. lb. (TW-50)
- AWH-100 bench-top tool holder with wrenches
- Reusable shipping container



Model	Description	Range
PGC-12-W2	Precision Calibration Package	0" - 12"

Additional Packages & Calibration Accessories

The following base units and accessories for larger requirements are available options to the standard MIC TRAC™ Package above.

Model	Description	Range
PGC-24-W2	Precision Calibration Package with MT-4024-10 MIC TRAC™	0" - 24"
PGC-36-W2	Precision Calibration Package with MT-4036-10 MIC TRAC™	0" - 36"
PGC-48-W2	Precision Calibration Package with MT-4048-10 MIC TRAC™	0" - 48"

MIC TRAC™ Package Training Options

We also offer expert-led training for our precision gage calibration systems at your location or at our facility. Please contact customer service for more information.

PGC-__-W2 Training Options:	Option A: Training at customer's facility (per day, plus airfare)
	Option B: Training at Gagemaker's facility (per day, per person)

MT-4000 Base Units with Extended Software Functions

A MIC TRAC™ 4000 base unit supplied only with digital readout software with extended functions, a computer, TF-2R setting blocks, and shipping carton.

Model	Description	Accuracy	Resolution	Range
MT-4012-10	MIC TRAC™ Base Unit	$\pm 0.00005"$	$.00001"$	0" - 12"
MT-4024-10	MIC TRAC™ Base Unit	$\pm 0.00010"$	$.00001"$	0" - 24"
MT-4036-10	MIC TRAC™ Base Unit	$\pm 0.00015"$	$.00001"$	0" - 36"
MT-4048-10	MIC TRAC™ Base Unit	$\pm 0.00020"$	$.00001"$	0" - 48"

Precision Gage Calibration System (MT-4000) Accessories

Gagemaker provides various accessories to expand the functionality of the MIC TRAC™ 4000 base unit. Some of the following are included as a package, but they are also available individually.

Model	Description
AWH-100	Hex wrench holder with wrenches
CRC-MT4000	Complete procedural documentation for the calibration of handheld inspection equipment including: O.D. & I.D. micrometers, calipers, depth micrometers, ring and plug gages, and more.
MT-4-USB	Digital readout software module with digital data acquisition card w/ CERTIFI™
TDWIN	Thread Disk software for calculating critical setting dimensions for threads. Includes UN Series, Acme, Stub Acme, ISO Metric, and 7° X 45° Buttress thread forms.
TF-2R	3/8" diameter carbide anvil set
TF-SB	Adjustable height support table
TF-SB-1	Bearing rail support base
TF-XYT	Adjustable height support table, X-axis & Y-axis support base
TW-50	50 in-lb torque wrench with 5/32" hex wrench adapter
<i>Cylindrical Ring & Thread Ring and Plug Gage Accessories</i>	
TF-1F	Flat face setting blocks
TF-1F-C	Carbide flat face setting blocks
TF-CP	Ball contact holders, .500 ID measurement
TF-CR	Set of 3 fixtures for measuring cylindrical ring gages and bores. CR-1 (.170"-.249"), CR-2 (.250"-.879"), CR-3 (.880" - Larger)
TF-IT	Internal threaded ring arm P.D. module (for solid threaded ring gages). Contains ball contacts and holders for 6, 8, 10, 12, 14, 16, 18, and 20 pitch 60° threads (Diameter range 1.500" & Larger).
TF-SP-5	For vertically holding gage pins .062" - .500"
TF-SP-75	For vertically holding gage pins .062" - .750"
TF-TP	Calibration fixture for NPT, NPTF and ANPT tapered plug gages (includes wire for 27, 18, 14, and 11½ pitch threaded plugs). (Requires TF-2R blocks)
<i>Thread Wire Holder Modules for UN, Acme, and Metric Threads</i>	
All wire holders require TF-2R Blocks and are supplied with one set of wires. Please specify pitch required. Note: "___" denotes pitch, ex. TF-WHV-12 = 60° thread wire holder module with wires 12 pitch.	
TF-WHV-___	60° thread wire holder module with your choice of wires. Please select one pitch from the following range: 5 pitch to 48 pitch
TF-WHVP-___	60° thread wire holder module with your choice of wires. Please select one pitch from the following range: 1 pitch to 4 pitch or 56 pitch to 72 pitch
TF-WHA-___	29° thread wire holder module with your choice of wires. Please select one pitch from the following range: 4 pitch to 20 pitch
TF-WHAP-___	29° thread wire holder module with your choice of 2 pitch or 3 pitch wires
TF-WHM-___	Metric thread wire holder module with your choice of wires. Please select one pitch from the following range: 0.5 mm pitch to 0.8 mm pitch or 5 mm pitch to 6 mm pitch
TF-WHM-___	Metric thread wire holder module with your choice of wires. Please select one pitch from the following range: 1.0 mm pitch to 4.5 mm pitch
TF-WSV	Thread wire holder Set. Contains wires and holders for 6, 8, 10, 12, 14, 16, 18, 20, 24, 28 and 32 pitch 60° threads.
TF-WSA	Thread wire holder Set. Contains wires and holders for 4, 5, 6, 8, 10, 12, 14 and 16 pitch Acme 29° threads.
TF-WSM	Thread wire holder set. Contains wires and holders for .5, .6, .75, 1.0, 1.25, 1.5, 2.0, 3.0, 4.0 and 5.0 pitch metric 60° threads.
TF-WH-___	Wire holder only (Indicate V, A, or M and then wire size or pitch)

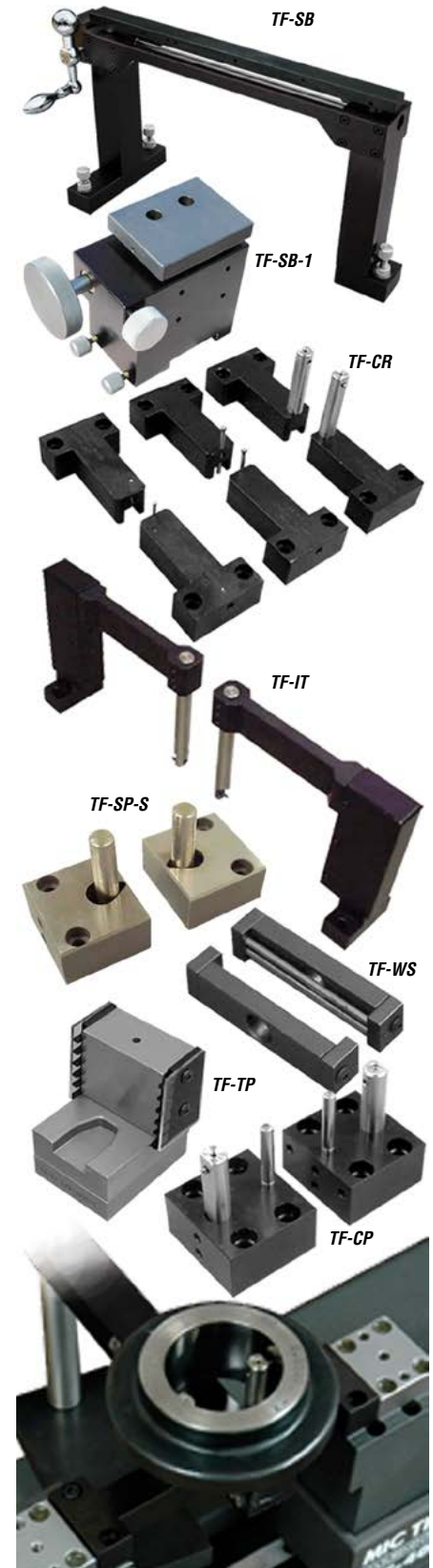



Gagemaker Products

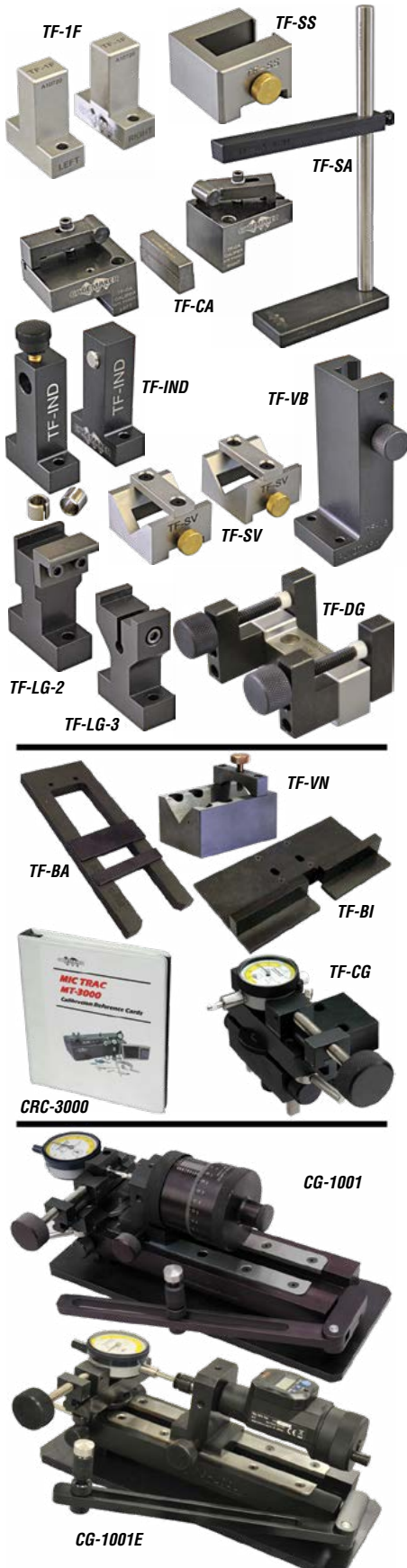

MIC TRAC™ System Options

The following accessories are available for larger requirements for either the MIC TRAC™ 3000 or MIC TRAC™ 4000.

Model	Description
CAL-PAK	Complete Calibration Package Includes: TF-1F, TF-CA, TF-DG, TF-IND, TF-LG-2, TF-LG-3, TF-SA, TF-SS, TF-SV, TF-VB, and storage case (included with a MT-4000 Package (PGC-12-W2, etc.))
TF-IND	AGD dial indicator. Calibration fixture (includes .375" and 8mm bushing)
TF-DG	Calibration fixture for depth micrometer*
TF-CA	Caliper calibration accessory dial, digital and vernier calipers. Includes TF-SA support arm.
TF-TI	Test indicator calibration block*
TF-SA	Support arm for TF-CA.
TF-SS	Straight support accessory for support of extended probes*
TF-SV	"V" support accessory for calibrating micrometers and standards**
TF-VN	"V" blocks for calibration of axial travel probes and bore gages
TF-1F	Flat face setting block set (2 blocks) 1.5000" outside diameter
TF-BA	Base support block for setting dial bore gages**
TF-VB	"V" block fixture for calibration of Gagemaker's TH-3004 and MRP-2002 Upper arms*
TF-LG-2	Lead gage calibration fixture for either Allen or Gagemaker gages (LG-5002)
TF-LG-3	Gagemaker lead gage (LG-5003) calibration fixture*
TF-BI	Base support plate for setting dial bore gages**
TF-CG	Universal clamping fixture for calibration of indicators and gages*
CRC-MT3000	Complete procedural documentation for the calibration of handheld inspection equipment including: O.D. & I.D. micrometers, calipers, depth micrometers, and more. (MT-3000 ONLY)
CRC-MT4000	Complete procedural documentation for the calibration of handheld inspection equipment including: O.D. & I.D. micrometers, calipers, depth micrometers, ring and plug gages, and more. (MT-4000 ONLY)

*1 TF-1F block required with this accessory

**2 TF-1F blocks required with this accessory

Bench Calibrator

The Gagemaker bench calibrator, CG-1001/CG-1001E, calibrates gages and indicators per AGD specification. The CG-1001 uses a non-rotating spindle screw type micrometer which reads directly to .0001" and can be estimated to the closest .00005".

Disassembling the gage is not required for calibration. The vise assembly allows full vertical and horizontal adjustment of the gage or indicator clamped in the vise jaws. During calibration, an outboard arm and arm support allows for larger gage assemblies to be securely supported. Four supplied accessory fixtures will help speed up calibration while maintaining accuracy.*

The CG-1001 is our standard bench calibrator, while the CG-1001E is our digital version which includes an SPC output.

Bench Calibrators are shipped in a durable custom shipping/storage case. Optional wooden storage cases are available.

Model	Description	Range	Accuracy
CG-1001	Bench Calibrator	.0001" Resolution, Mechanical	±.0001
CG-1001E	Digital Bench Calibrator Gage w/ SPC Output	.00005"/.001 mm Resolution, Digital	±.00015

*Individual replacement fixtures are available for purchase but not listed above.
Please call for more information.

API 6A Seal Ring Groove Gages (BX/RX)

Face Groove and Hole Location Gages

Gagemaker's face groove gages inspect groove diameters and groove widths. Excellent for inspecting hole locations. Additional extensions for various lengths are available, please contact customer service for more.

Model	Description	Range
BX-900	Ball Mic Gage w/ Ball Points (no indicator)	BX, R, RX Grooves, Diameters 2.6" - 13"
BX-1000	6B Groove Diameter Gage w/ T188 Points	BX, R, RX Grooves, Diameters 2.6" - 13"
BXG-1000	6B Groove Width Gage w/ T072 Points	BX, R, RX Grooves, Widths .375" - 1.5"
BXG-1002	Special Groove Width Gage w/ T072 Points	Special Groove, Widths 2.0"
BX-R13	Optional Extension rod for BX-1000, 13"	Groove Diameters to 13"
BX-R24	Optional Extension rod for BX-1000, 24"	Groove Diameters to 25"
BX-R30	Optional Extension rod for BX-1000, 30"	Groove Diameters to 31"
BX-R36	Optional Extension rod for BX-1000, 36"	Groove Diameters to 37"
PD-BX	BX/BXG Setting Gage, 1/2" X 1/2" U-notch	

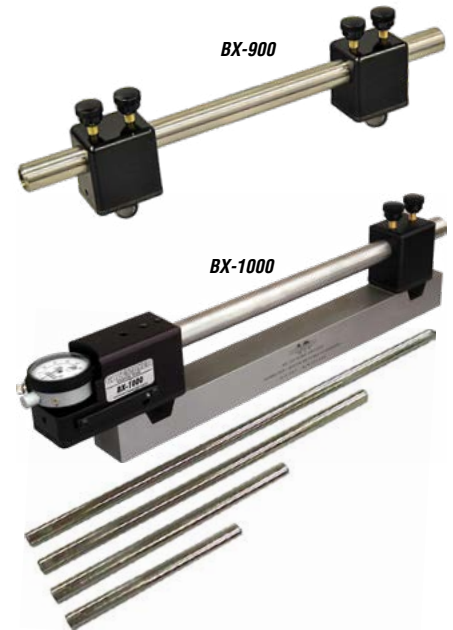

Face Groove and Hole Location Gage Setting Masters

Model	Description	Model	Description
FSBX-150	Setting Master for BX-150	FSBX-162	Setting Master for BX-162
FSBX-151	Setting Master for BX-151	FSBX-163	Setting Master for BX-163
FSBX-152	Setting Master for BX-152	FSBX-164	Setting Master for BX-164
FSBX-153	Setting Master for BX-153	FSBX-165	Setting Master for BX-165
FSBX-154	Setting Master for BX-154	FSBX-166	Setting Master for BX-166
FSBX-155	Setting Master for BX-155	FSBX-167	Setting Master for BX-167
FSBX-156	Setting Master for BX-156	FSBX-168	Setting Master for BX-168
FSBX-157	Setting Master for BX-157	FSBX-169	Setting Master for BX-169
FSBX-158	Setting Master for BX-158	FSBX-170	Setting Master for BX-170
FSBX-159	Setting Master for BX-159	FSBX-171	Setting Master for BX-171
FSBX-160	Setting Master for BX-160	FSBX-172	Setting Master for BX-172
FSBX-161	Setting Master for BX-161	FSBX-303	Setting Master for BX-303



BX - Dog Bone/Paddle Gage

Model	Description	Model	Description
DBBX-150	Dog Bone Ring Groove Gage BX-150	DBBX-162	Dog Bone Ring Groove Gage BX-162
DBBX-151	Dog Bone Ring Groove Gage BX-151	DBBX-163	Dog Bone Ring Groove Gage BX-163
DBBX-152	Dog Bone Ring Groove Gage BX-152	DBBX-164	Dog Bone Ring Groove Gage BX-164
DBBX-153	Dog Bone Ring Groove Gage BX-153	DBBX-165	Dog Bone Ring Groove Gage BX-165
DBBX-154	Dog Bone Ring Groove Gage BX-154	DBBX-166	Dog Bone Ring Groove Gage BX-166
DBBX-155	Dog Bone Ring Groove Gage BX-155	DBBX-167	Dog Bone Ring Groove Gage BX-167
DBBX-156	Dog Bone Ring Groove Gage BX-156	DBBX-168	Dog Bone Ring Groove Gage BX-168
DBBX-157	Dog Bone Ring Groove Gage BX-157	DBBX-169	Dog Bone Ring Groove Gage BX-169
DBBX-158	Dog Bone Ring Groove Gage BX-158	DBBX-170	Dog Bone Ring Groove Gage BX-170
DBBX-159	Dog Bone Ring Groove Gage BX-159	DBBX-171	Dog Bone Ring Groove Gage BX-171
DBBX-160	Dog Bone Ring Groove Gage BX-160	DBBX-172	Dog Bone Ring Groove Gage BX-172
DBBX-161	Dog Bone Ring Groove Gage BX-161	DBBX-303	Dog Bone Ring Groove Gage BX-303





BX - Groove Profile & Width GO/NO GO Gage



DB-R36

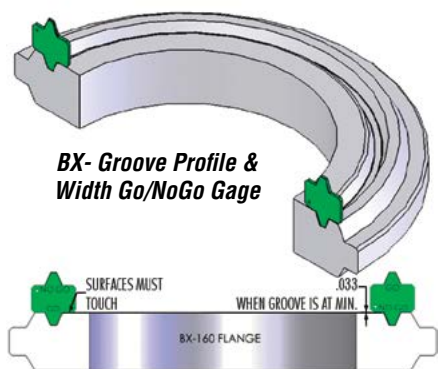

BX-Groove Profile & Width Go/NoGo Gage

BX-Dog Bone Paddle Gage

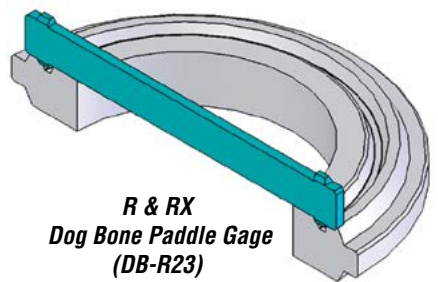

R & RX Dog Bone Paddle Gage (DB-R23)



Model	Description	Model	Description
BXP-150	GO/NO GO Profile Gage BX-150	BXP-162	GO/NO GO Profile Gage BX-162
BXP-151	GO/NO GO Profile Gage BX-151	BXP-163	GO/NO GO Profile Gage BX-163
BXP-152	GO/NO GO Profile Gage BX-152	BXP-164	GO/NO GO Profile Gage BX-164
BXP-153	GO/NO GO Profile Gage BX-153	BXP-165	GO/NO GO Profile Gage BX-165
BXP-154	GO/NO GO Profile Gage BX-154	BXP-166	GO/NO GO Profile Gage BX-166
BXP-155	GO/NO GO Profile Gage BX-155	BXP-167	GO/NO GO Profile Gage BX-167
BXP-156	GO/NO GO Profile Gage BX-156	BXP-168	GO/NO GO Profile Gage BX-168
BXP-157	GO/NO GO Profile Gage BX-157	BXP-169	GO/NO GO Profile Gage BX-169
BXP-158	GO/NO GO Profile Gage BX-158	BXP-170	GO/NO GO Profile Gage BX-170
BXP-159	GO/NO GO Profile Gage BX-159	BXP-171	GO/NO GO Profile Gage BX-171
BXP-160	GO/NO GO Profile Gage BX-160	BXP-172	GO/NO GO Profile Gage BX-172
BXP-161	GO/NO GO Profile Gage BX-161	BXP-303	GO/NO GO Profile Gage BX-303

R & RX - Dog Bone/Paddle Gage

Model	Description	Model	Description
DB-R20	Dog Bone Ring Groove Gage R-RX20	DB-R57	Dog Bone Ring Groove Gage R-RX57
DB-R23	Dog Bone Ring Groove Gage R-RX23	DB-R63	Dog Bone Ring Groove Gage R-RX63
DB-R24	Dog Bone Ring Groove Gage R-RX24	DB-R65	Dog Bone Ring Groove Gage R-RX65
DB-R25	Dog Bone Ring Groove Gage R-RX25	DB-R66	Dog Bone Ring Groove Gage R-RX66
DB-R26	Dog Bone Ring Groove Gage R-RX26	DB-R69	Dog Bone Ring Groove Gage R-RX69
DB-R27	Dog Bone Ring Groove Gage R-RX27	DB-R70	Dog Bone Ring Groove Gage R-RX70
DB-R31	Dog Bone Ring Groove Gage R-RX31	DB-R73	Dog Bone Ring Groove Gage R-RX73
DB-R35	Dog Bone Ring Groove Gage R-RX35	DB-R74	Dog Bone Ring Groove Gage R-RX74
DB-R37	Dog Bone Ring Groove Gage R-RX37	DB-R82	Dog Bone Ring Groove Gage R-RX82
DB-R39	Dog Bone Ring Groove Gage R-RX39	DB-R84	Dog Bone Ring Groove Gage R-RX84
DB-R41	Dog Bone Ring Groove Gage R-RX41	DB-R85	Dog Bone Ring Groove Gage R-RX85
DB-R44	Dog Bone Ring Groove Gage R-RX44	DB-R86	Dog Bone Ring Groove Gage R-RX86
DB-R45	Dog Bone Ring Groove Gage R-RX45	DB-R87	Dog Bone Ring Groove Gage R-RX87
DB-R46	Dog Bone Ring Groove Gage R-RX46	DB-R88	Dog Bone Ring Groove Gage R-RX88
DB-R47	Dog Bone Ring Groove Gage R-RX47	DB-R89	Dog Bone Ring Groove Gage R-RX89
DB-R49	Dog Bone Ring Groove Gage R-RX49	DB-R90	Dog Bone Ring Groove Gage R-RX90
DB-R50	Dog Bone Ring Groove Gage R-RX50	DB-R91	Dog Bone Ring Groove Gage R-RX91
DB-R53	Dog Bone Ring Groove Gage R-RX53	DB-R99	Dog Bone Ring Groove Gage R-RX99
DB-R54	Dog Bone Ring Groove Gage R-RX54		

R-RX - Groove Profile & Width GO/NO GO Gage

Model (RP-Depth-Width)*	Corresponding R Groove Size
RP-250-344	R 20
RP-310-469	R 23 to R45, R49, R53, R57, R65, R69, R82, R84, & R99
RP-380-531	R46, R73, R85
RP-440-656	R50, R54, R66, R86, R87
RP-500-781	R47, R70, R74, R88
RP-560-906	R90
RP-620-1063	R63
RP-690-1313	R91

*ex. RP-250-344 = .250" (depth), .344" (width)

Groove Width Amplifier Gages

Groove width amplifier gages use flushpins to indicate acceptance or rejection.

Model	Description	Groove Width
AG-BX150	Groove Width Amplifier Gage, BX-150	0.450"
AG-BX151	Groove Width Amplifier Gage, BX-151	0.466"
AG-BX152	Groove Width Amplifier Gage, BX-152	0.498"
AG-BX153	Groove Width Amplifier Gage, BX-153	0.554"
AG-BX154	Groove Width Amplifier Gage, BX-154	0.606"
AG-BX155	Groove Width Amplifier Gage, BX-155	0.698"
AG-BX156	Groove Width Amplifier Gage, BX-156	0.921"
AG-BX157	Groove Width Amplifier Gage, BX-157	1.039"
AG-BX158	Groove Width Amplifier Gage, BX-158	1.149"
AG-BX159	Groove Width Amplifier Gage, BX-159	1.279"
AG-BX160	Groove Width Amplifier Gage, BX-160	0.786"
AG-BX161	Groove Width Amplifier Gage, BX-161	0.930"
AG-BX162	Groove Width Amplifier Gage, BX-162	0.705"
AG-BX163	Groove Width Amplifier Gage, BX-163	1.006"
AG-BX164	Groove Width Amplifier Gage, BX-164	1.290"
AG-BX165	Groove Width Amplifier Gage, BX-165	1.071"
AG-BX166	Groove Width Amplifier Gage, BX-166	1.373"
AG-BX167	Groove Width Amplifier Gage, BX-167	0.902"
AG-BX168	Groove Width Amplifier Gage, BX-168	1.018"
AG-BX169	Groove Width Amplifier Gage, BX-169	0.666"



AG-BX156



AG-BX151

CamLock Micrometers

The CamLock micrometers measure API weld flange thickness. Supplied with verification standard. Replacement standards are available separately, please call for quotation.

Model	Description	Range
CL-1001	CamLock Micrometer- 25°	0" - 1"
CL-1002	CamLock Micrometer- 25°	1" - 2"
CL-1003	CamLock Micrometer- 25°	2" - 3"
CL-1004	CamLock Micrometer- 25°	3" - 4"

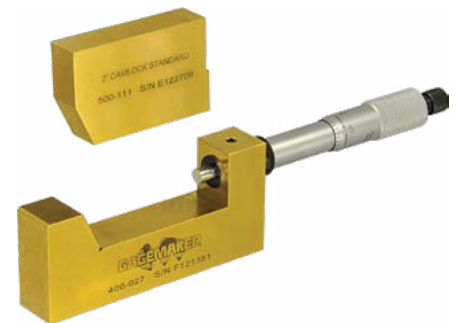

CL-1002 with Verification Standard



Stator Minor Bore Inspection

Stator Bore Gages

The SBG series of gages determines a precise stator/rotor match by measuring the largest and smallest bore diameters. SBG-5000 gages measure diameters from 1.500" - 7.500" and are available in three models: an analog indicator (SBG-5000A), a digital indicator (SBG-5000D), and an electronic (SBG-5000E). Attaching or removing different height extension shoes achieves the gage's range flexibility. All gage models can address any pitch or lobe configuration.

The SBG-5000A and SBG-5000D include three extension shoes and setting standard base without a setting standard.

The SBG-5000E includes three extension shoes, interface box, a computer, measurement software, necessary cables, and setting standard base without a setting standard.

Custom sized standards, round standards, and shoes are available. Setting standards are sold separately. See the chart on page 141 for setting standard sizes.

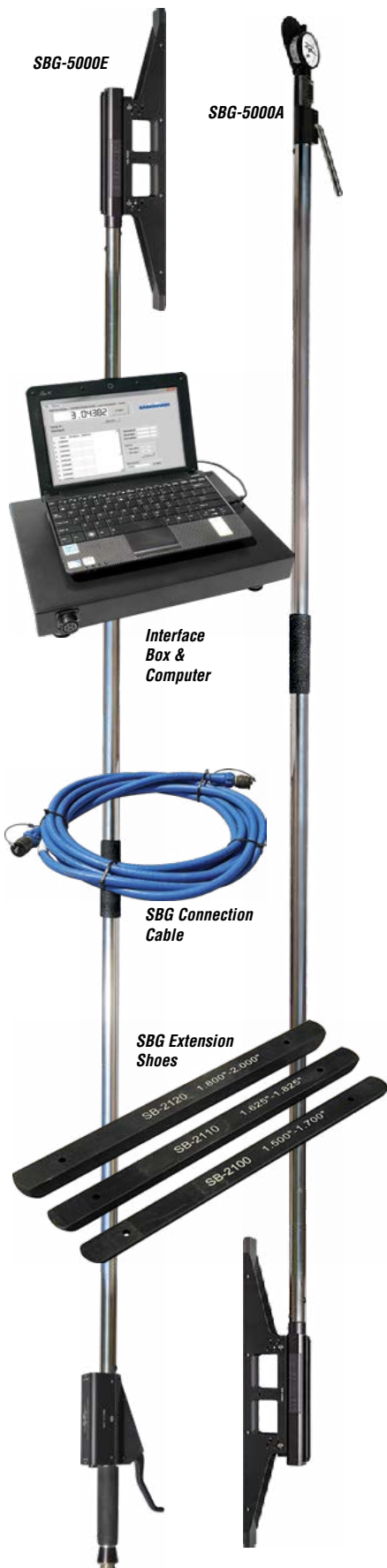

Model	Description	Range
SBG-5000A	Stator Bore Gage with analog indicator & SB-2100, SB-2110, and SB-2120 extension shoes	1.500" - 2.000"*
SBG-5000D	Stator Bore Gage with digital indicator & SB-2100, SB-2110, and SB-2120 extension shoes	1.500" - 2.000"*
SBG-5000E	Electronic Stator Bore Gage with interface box, computer, software, standard base, & SB-2100, SB-2110, and SB-2120 extension shoes	1.500" - 2.000"*

**Additional shoes are required for diameters exceeding 2.000".*

SBG-5000A, SBG-5000D & SBG-5000E Extension Shoes

The style of extension shoe depends on the diameter range being measured. Shoes are offered in several lengths depending on the pitch of the stator lobes. It is important that the shoe length be long enough to contact a minimum of two points on the bottom and one point on the top pad. Custom shoes are available as special request. Contact Gagemaker for more information.

Model	Description	Range
SB-2100	8" long extension shoe	1.500" - 1.650"
SB-2110	8" long extension shoe	1.650" - 1.800"
SB-2120	8" long extension shoe	1.800" - 1.950"
SB-2200	20" extension shoe (requires riser)	
SB-2150	.130" riser - SB-2200 extension shoe required	2.000" - 2.150"
SB-2300	.280" riser - SB-2200 extension shoe required	2.150" - 2.300"
SB-2400	.380" riser - SB-2200 extension shoe required	2.250" - 2.400"
SB-2500	.480" riser - SB-2200 extension shoe required	2.350" - 2.550"
SB-2600	.580" riser - SB-2200 extension shoe required	2.450" - 2.600"
SB-3500	20" extension shoe w/ brackets and adapter	2.600" - 3.500"
SB-4500	20" extension shoe w/ brackets and adapter	3.450" - 4.500"
SB-5500	20" extension shoe w/ brackets and adapter	4.450" - 5.500"
SB-6500	20" extension shoe w/ brackets and adapter	5.450" - 6.500"
SB-7500	20" extension shoe w/ brackets and adapter	6.450" - 7.500"

SBG-5000A, SBG-5000D, & SBG-5000E Flat Standards

Setting standards do not need to be sized to the exact bore of the stator's bore. As long as the size of the standard is within the measurement range of the gage, it can be used to preset the gage. Custom sizes and round standards are available as special requests.

Setting Master Height	Flat Standard Model	Setting Master Height	Flat Standard Model
1.600"	SBFS-1600	4.640"	SBFS-4640
1.727"	SBFS-1727	4.750"	SBFS-4750
1.800"	SBFS-1800	4.900"	SBFS-4900
2.062"	SBFS-2062	5.060"	SBFS-5060
2.187"	SBFS-2187	5.150"	SBFS-5150
2.375"	SBFS-2375	5.240"	SBFS-5240
2.598"	SBFS-2598	5.350"	SBFS-5350
2.700"	SBFS-2700	5.420"	SBFS-5420
2.736"	SBFS-2736	5.500"	SBFS-5500
2.900"	SBFS-2900	5.600"	SBFS-5600
3.080"	SBFS-3080	5.750"	SBFS-5750
3.150"	SBFS-3150	5.850"	SBFS-5850
3.245"	SBFS-3245	5.960"	SBFS-5960
3.303"	SBFS-3303	6.050"	SBFS-6050
3.400"	SBFS-3400	6.140"	SBFS-6140
3.425"	SBFS-3425	6.250"	SBFS-6250
3.500"	SBFS-3500	6.375"	SBFS-6375
3.625"	SBFS-3625	6.500"	SBFS-6500
3.750"	SBFS-3750	6.600"	SBFS-6600
3.976"	SBFS-3976	6.750"	SBFS-6750
4.000"	SBFS-4000	6.860"	SBFS-6860
4.160"	SBFS-4160	6.950"	SBFS-6950
4.250"	SBFS-4250	7.040"	SBFS-7040
4.370"	SBFS-4370	7.220"	SBFS-7220
4.520"	SBFS-4520	7.375"	SBFS-7375
4.567"	SBFS-4567	7.450"	SBFS-7450

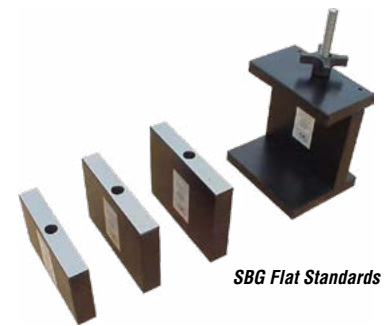

SBG Flat Standards



SBG Extension Shoes



SBG Risers

SB-2200 with Riser

SBG-5000A, SBG-5000D & SBG-5000E Extension Shoes

The style of extension shoe depends on the diameter range being measured. Shoes are offered in several lengths depending on the pitch of the stator lobes. It is important that the shoe length be long enough to contact a minimum of two points on the bottom and one point on the top pad. Custom shoes are available as special request. Contact Gagemaker for more information.

Model	Description	Range
SB-2100	8" long extension shoe	1.500" – 1.650"
SB-2110	8" long extension shoe	1.650" – 1.800"
SB-2120	8" long extension shoe	1.800" – 1.950"
SB-2200	20" extension shoe (requires riser)	
SB-2150	.130" riser – SB-2200 extension shoe required	2.000" – 2.150"
SB-2300	.280" riser – SB-2200 extension shoe required	2.150" – 2.300"
SB-2400	.380" riser – SB-2200 extension shoe required	2.250" – 2.400"
SB-2500	.480" riser – SB-2200 extension shoe required	2.350" – 2.550"
SB-2600	.580" riser – SB-2200 extension shoe required	2.450" – 2.600"
SB-3500	20" extension shoe w/ brackets and adapter	2.600" – 3.500"
SB-4500	20" extension shoe w/ brackets and adapter	3.450" – 4.500"
SB-5500	20" extension shoe w/ brackets and adapter	4.450" – 5.500"
SB-6500	20" extension shoe w/ brackets and adapter	5.450" – 6.500"
SB-7500	20" extension shoe w/ brackets and adapter	6.450" – 7.500"



SBG-4500

SBG-3500



Rotor Inspection

Today in the oil field industry, unique high-performance power sections require accurate measurement tools for rotors and stators. Gagemaker has designed several gages to measure various parts of the rotor.

Rotor Major Diameter Micrometer (T-MIC)

Due to high spirals on the lobes, conventional measurement gages cannot be used for measuring rotor major diameters. Gagemaker developed the T-MIC to measure a rotor's major diameter. The T-MIC's base spans across two lobes on one side of the centerline and uses a micrometer thimble on the other to measure the diameter. Instead of modifying an existing micrometer, Gagemaker custom builds each T-MIC. Gagemaker's rugged design far exceeds all others on the market today. Special sizes are available, contact customer service for more information. **Special sizes, metric thimbles, and metric sizes are available.**



TM12-4-5

Range	Model					Description
	6" Base	8" Base	12" Base	18" Base	24" Base	
0" - 1"	TM6-0-1	TM8-0-1	TM12-0-1	TM18-0-1	TM24-0-1	T-MIC for Rotor, 1/2" wide base
1" - 2"	TM6-1-2	TM8-1-2	TM12-1-2	TM18-1-2	TM24-1-2	
2" - 3"	TM6-2-3	TM8-2-3	TM12-2-3	TM18-2-3	TM24-2-3	
3" - 4"	TM6-3-4	TM8-3-4	TM12-3-4	TM18-3-4	TM24-3-4	
4" - 5"	TM6-4-5	TM8-4-5	TM12-4-5	TM18-4-5	TM24-4-5	
5" - 6"	TM6-5-6	TM8-5-6	TM12-5-6	TM18-5-6	TM24-5-6	
6" - 7"	TM6-6-7	TM8-6-7	TM12-6-7	TM18-6-7	TM24-6-7	
7" - 8"	TM6-7-8	TM8-7-8	TM12-7-8	TM18-7-8	TM24-7-8	
8" - 9"	TM6-8-9	TM8-8-9	TM12-8-9	TM18-8-9	TM24-8-9	

Rotor Major Diameter T-Micrometer with Digital Micrometer

Gagemaker also offers our T-MICs with digital micrometers. The digital micrometer can transfer your data to a computer via the included SPC output. **Special sizes, metric thimbles, and metric sizes are available.**



TM12-2-3-352

Range	Model					Description
	6" Base	8" Base	12" Base	18" Base	24" Base	
0" - 1"	TM6-0-1-352	TM8-0-1-352	TM12-0-1-352	TM18-0-1-352	TM24-0-1-352	T-MIC for Rotor, 1/2" wide base with a Mitutoyo 50-352-10 digital microm- eter and SPC output
1" - 2"	TM6-1-2-352	TM8-1-2-352	TM12-1-2-352	TM18-1-2-352	TM24-1-2-352	
2" - 3"	TM6-2-3-352	TM8-2-3-352	TM12-2-3-352	TM18-2-3-352	TM24-2-3-352	
3" - 4"	TM6-3-4-352	TM8-3-4-352	TM12-3-4-352	TM18-3-4-352	TM24-3-4-352	
4" - 5"	TM6-4-5-352	TM8-4-5-352	TM12-4-5-352	TM18-4-5-352	TM24-4-5-352	
5" - 6"	TM6-5-6-352	TM8-5-6-352	TM12-5-6-352	TM18-5-6-352	TM24-5-6-352	
6" - 7"	TM6-6-7-352	TM8-6-7-352	TM12-6-7-352	TM18-6-7-352	TM24-6-7-352	
7" - 8"	TM6-7-8-352	TM8-7-8-352	TM12-7-8-352	TM18-7-8-352	TM24-7-8-352	
8" - 9"	TM6-8-9-352	TM8-8-9-352	TM12-8-9-352	TM18-8-9-352	TM24-8-9-352	

Rotor Minor Diameter Micrometer (MM)

Gagemaker's minor diameter MIC gage was designed to measure a rotor's minor diameter. The spiral lobes on the rotor produce a valley, or minor diameter. The depth of the minor diameter from the major diameter requires a 1" travel indicator stem. Gage range is 0" - 6", which allows measuring most rotor sizes with only one gage. Ensuring the gage's durability and long life, Gagemaker's design uses a heavy duty indicator stem and bearing housing to withstand side loads. Special sizes are available.

Model	Description	Range
MM-0-6	Minor diameter micrometer	0" - 6"



Rotor Saddle Gage

The rotor saddle gage, also known as a rotor lobe height gage, is the last weapon in the inspection arsenal. This gage sets on top of the spiral lobes of the rotor and measures the variation in lobe height. Sliding the gage along the length of the rotor detects variation in root to crest height of all the lobes. Measurements can be taken at 90° or 180° intervals to provide an accurate dimensional map of the relationship between lobes. This inspection aids in manufacturing the rotor to specification.

Model	Description	Travel	Pipe Diameter Range
RSG-7	Rotor saddle gage, 7" long	1"	1" - 4"
RSG-16	Rotor saddle gage, 16" long	1"	1" - 4"
RSG-24	Rotor saddle gage, 24" long	1"	1" - 4"

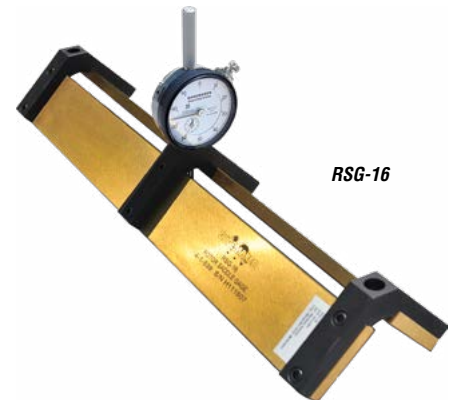



Pin Seal Diameter Gages

The Pin Seal Diameter Series of gages inspect critical pin seal diameters and seal tapers on premium connections. With the addition of stand-off plates, the gages also inspect seal tapers. Each model covers a specific range of connection sizes, making the PN-3000 gages extremely versatile and economical.

The PN-3000 gages use precision interchangeable contact points that position on the seal at a fixed distance from the connection face during inspection.

Before inspecting parts, these gages must be preset to a nominal predetermined dimension using gage blocks, Gagemaker's Pin Seal Diameter Gauge Setting Master, a MIC TRAC™, or Frame Standards.

Features

- Provides accurate measurements on the gage's indicator at the critical sealing point of the pin.
- Uses interchangeable contact points
- Includes a .0005" resolution indicator.
- Requires presetting using gage blocks, Gagemaker's Pin Seal Diameter Gauge Setting Master, Frame Standards, or MIC TRAC™ system.
- Allows use in a manufacturing or field environment due to durable construction

PN-3000 Series Pin Nose Diameter Gages*

The PN series measure pin nose diameter using contact points. Specify the distance from the face of the connection to the measuring plane and desired contact point diameter when ordering.

Model	Description	Range
PN-3001	Pin Nose Diameter Gage	0" - 5½"
PN-3002	Pin Nose Diameter Gage	0" - 9½"
PN-3003	Pin Nose Diameter Gage	0" - 13½"
PN-3004	Pin Nose Diameter Gage	0" - 19½"
PN-3005	Pin Nose Diameter Gage	0" - 25½"

*There is a separate cost to reposition the point standoff of PN-3000 Gages. Quotation available upon request.

PN-3000 Series Internal "Ball Contact" Seal Diameter Gages

The PNI series measure the internal ball contact seal diameter using contact points. Specify the distance from the face of the connection to the measuring plane and desired contact point diameter when ordering. Larger ranges may be available as a custom order.

Model	Description	Range
PNI-3001-VMB	Internal "Ball Contact" Seal Diameter Gage	2" - 5½"
PNI-3002-VMB	Internal "Ball Contact" Seal Diameter Gage	2" - 9½"
PNI-3003-VMB	Internal "Ball Contact" Seal Diameter Gage	2" - 13½"

PN-3000 Series 30° External Apex Diameter Gages

The PNA model gages measure only the external apex diameter of the connection. Larger ranges may be available as a custom order.

Model	Description	Range
PNA-3001-VMA	30° External Apex Diameter Gage, Anvils	2" - 4¼"
PNA-3002-VMA	30° External Apex Diameter Gage, Anvils	2" - 9½"
PNA-3003-VMA	30° External Apex Diameter Gage, Anvils	2" - 13¾"

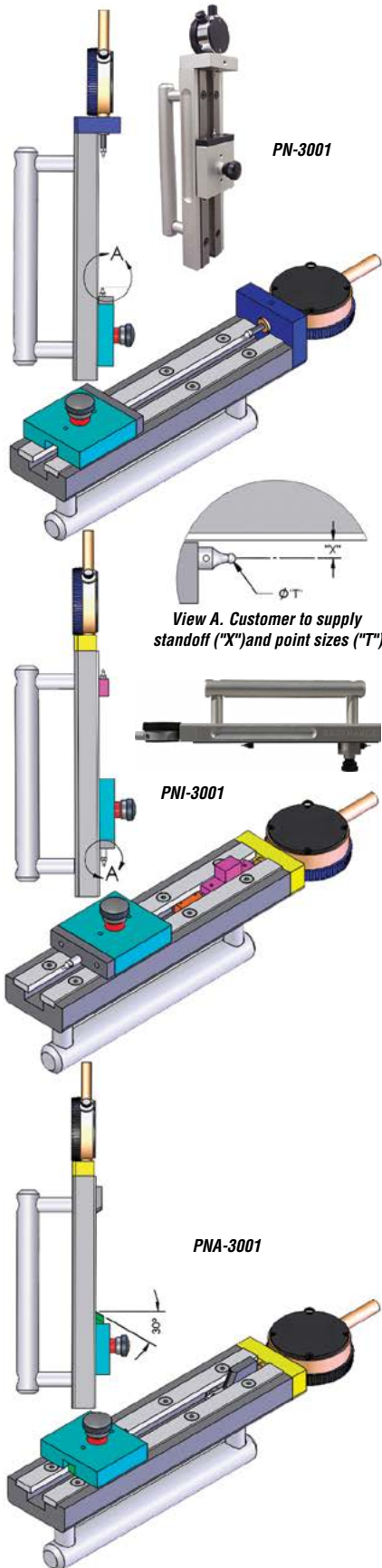

PN-3000 Series 30° Internal/External Apex Seal Diameter Gages

The PN-3000 Series 30° Internal/External Apex Seal Diameter gages measure both the internal and external diameters of the apex seal for the connection.

Model	Description	Range
PN-31VM-30	30° Internal/External Apex Seal Diameter "V"	External 4" - 6 $\frac{5}{8}$ ", Internal 2 $\frac{3}{8}$ " - 6 $\frac{5}{8}$ "
PN-33VM-30	30° Internal/External Apex Seal Diameter "V"	External 4" - 14", Internal 2 $\frac{3}{8}$ " - 14"

Pin Seal Diameter Gage Standoff Plates

The pin seal standoff plates are available in various sizes. Additional custom sizes are available upon request. Pin seal standoff plates are sold as a set of two.

Model	Description	Range
PN-3000/T.04087	Pin Seal Standoff Plate*	0.04087" (1.038 mm) thick
PN-3000/T.044	Pin Seal Standoff Plate*	0.0440" (1.12 mm) thick
PN-3000/T.0472	Pin Seal Standoff Plate*	0.0472" (1.20 mm) thick
PN-3000/T.0591	Pin Seal Standoff Plate*	0.0591" (1.50 mm) thick
PN-3000/T.064	Pin Seal Standoff Plate*	0.0640" (1.62 mm) thick
PN-3000/T.072	Pin Seal Standoff Plate*	0.0720" (1.83 mm) thick
PN-3000/T.0748	Pin Seal Standoff Plate*	0.0748" (1.90 mm) thick
PN-3000/T.078	Pin Seal Standoff Plate*	0.0780" (1.9812 mm) thick
PN-3000/T.0787	Pin Seal Standoff Plate*	0.0787" (2.00 mm) thick
PN-3000/T.0811	Pin Seal Standoff Plate*	0.0811" (2.06 mm) thick
PN-3000/T.0815	Pin Seal Standoff Plate*	0.0815" (2.07 mm) thick
PN-3000/T.094	Pin Seal Standoff Plate*	0.0940" (2.39 mm) thick
PN-3000/T.100	Pin Seal Standoff Plate*	0.1000" (2.54 mm) thick
PN-3000/T.114	Pin Seal Standoff Plate*	0.1140" (2.90 mm) thick
PN-3000/T.1181	Pin Seal Standoff Plate*	0.1181" (3.00 mm) thick
PN-3000/T.121	Pin Seal Standoff Plate*	0.1210" (3.07 mm) thick
PN-3000/T.122	Pin Seal Standoff Plate*	0.1220" (3.10 mm) thick
PN-3000/T.1378	Pin Seal Standoff Plate*	0.1378" (3.50 mm) thick
PN-3000/T.171	Pin Seal Standoff Plate*	0.1710" (4.34 mm) thick
PN-3000/T.1969	Pin Seal Standoff Plate*	0.1969" (5.00 mm) thick
PN-3000/T.200	Pin Seal Standoff Plate*	0.2000" (5.08 mm) thick
PN-3000/T.3149	Pin Seal Standoff Plate*	0.3149" (8.00 mm) thick
PN-3000/T.350	Pin Seal Standoff Plate*	0.3500" (8.89 mm) thick

*Additional plate thickness sizes are available. All plates are two per set.

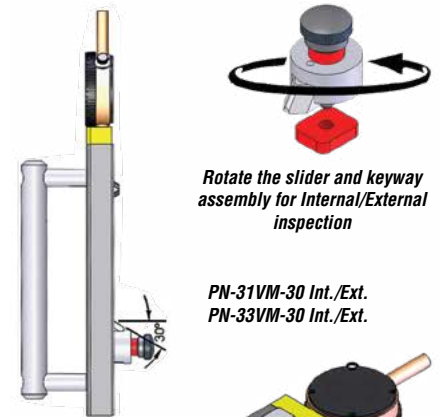

Rotate the slider and keyway assembly for Internal/External inspection

PN-31VM-30 Int./Ext.
PN-33VM-30 Int./Ext.

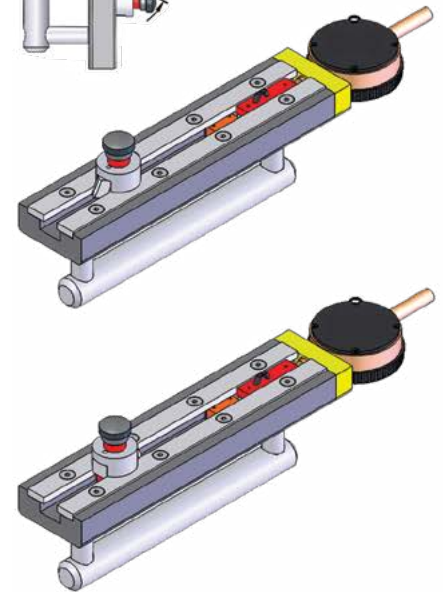

Customer to specify thickness ("T") of taper plates

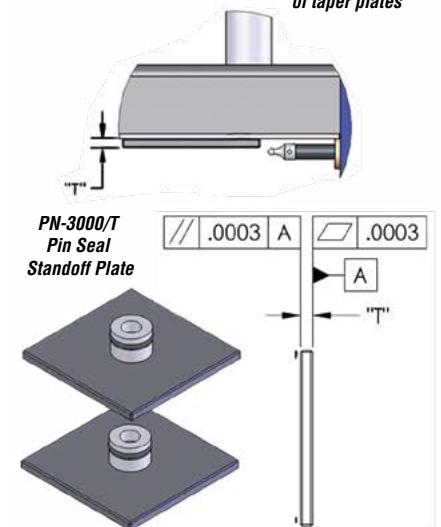

The round and frame style standards are designed to preset all models of the PN-3000 series gages for accurate inspection of API pin end seal taper diameters of premium connections. These standards consist of a rigid, non-adjustable steel block machined to precise, proper size tolerances.

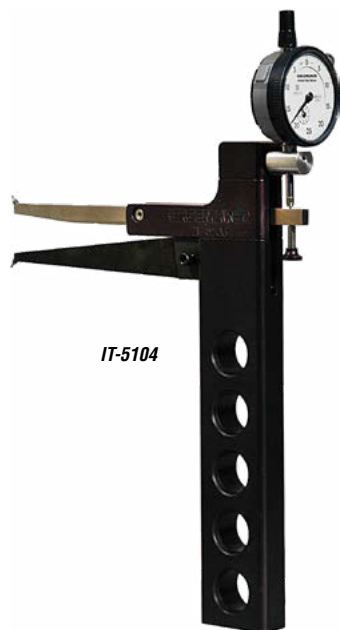

IT-5104

Internal Diameter/Groove Gages

Gagemaker's internal diameter and groove gages measure variation in internal bore diameters. Diameter/groove gages are shipped with two .072" diameter contact points (T072) as standard. Refer to the contact point pages 124-125 for the proper contact point for your particular application.

Model	Description	Range
IT-5104	Internal Diameter/Groove Gage	4" Depth, 1½" - 10" Dia.
IT-5106	Internal Diameter/Groove Gage	6" Depth, 1½" - 10" Dia.
IT-5106-30	Int. Diameter/Groove Gage, points at 30° angle	6" Depth, 1½" - 10" Dia.
IT-5106-45	Int. Diameter/Groove Gage, points at 45° angle	6" Depth, 1½" - 10" Dia.
IT-5108	Internal Diameter/Groove Gage	8" Depth, 1½" - 10" Dia.

Internal Diameter/Groove Gage Replacement Parts

Model	Description	Length
IT-5104-04	Replacement Lower Arm	4¼"
IT-5106-06	Replacement Lower Arm	6"
IT-5108-08	Replacement Lower Arm	8"
IT-5112-12	Replacement Lower Arm	12"



TW-6001

API Buttress Tooth Thickness & Groove Width Gages

API Buttress threads are governed by the Specification 5B. The latest edition mandates the inspection of tooth thickness (the actual tooth thickness, the groove width, or shave).



TW-5B-750

Tooth Thickness Gage

The TW-6001 Tooth Thickness Gage meets API requirements for measuring tooth thickness/width or shave on API Buttress connections. The gage is supplied with 3 contact points (2 T072, 1 T087T). A setting standard is required and sold separately.



TW-5B-1

Model	Description	Minimum Bore	Range
TW-6001	Tooth Thickness Gage	1.200	½" - 2" Thread Length
TW-5B-750	Tooth Thickness Standard, 0.750" Taper		
TW-5B-1	Tooth Thickness Standard, 1" Taper		



GW-1001

Groove Width Gages

The GW-1000 Groove Width Gage Series is comprised of Go/NoGo style gages used to quickly check the width of the groove on API Buttress connections. They meet the latest API inspection requirements for tooth thickness or groove width. Each model is for a certain taper and diameter.



GW-1002



GW-1003



GW-1004



GW-1005

Model	Description	Taper	Connection Diameter
GW-1001	Groove Width Go/NoGo Gage	¾"	4½" - 7⅝"
GW-1002	External Groove Width Go/NoGo Gage	¾"	4½" - 13⅜"
GW-1003	Internal Groove Width Go/NoGo Gage	¾"	8⅝" - 13⅜"
GW-1004	External Groove Width Go/NoGo Gage	1"	16 - 20"
GW-1005	Internal Groove Width Go/NoGo Gage	1"	16 - 20"

Pipe Straightness Gages

Saddle Gage

The Saddle Gage measures the amount of hook or bend at the end of a joint of pipe. The SG-8001 uses the RC-375 roller contact.

Model	Description	Range
SG-8001	Saddle Gage	All Sizes
SG-8001-TA	SG-8001 Tube Assembly	
RC-375	0.375" Diameter Roller Contact	



Squareness Gage

The SQ-1600 Squareness gage monitors the alignment of weld-on connectors to the pipe body. Requires setting by a qualified standard. The SQ-1630S, our precision calibration square, is strongly recommended for best results. Standard sold separately.

Model	Description	Range
SQ-1636	Squareness Gage, 30" reach	Up to 36" diameter
SQ-1648	Squareness Gage, 30" reach	Up to 48" diameter
SQ-1636S	Squareness Gage Standard	14" X 36" Square

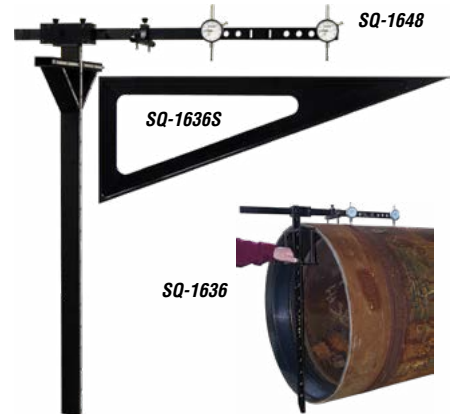

Straight Edge Gage

The SE-1000 Straight Edge gage measures the straightness of well tubing and casing. The gage price includes an SES-1000 Standard. Replacement standards are available.

Model	Description	Range
SE-1000	Straight Edge	36" - 64"
SES-1000	Replacement Straight Edge Standard	



Laser Alignment Gage

The Laser Alignment Gage ensures proper angular and parallel alignment during assembly of weld-on connectors. Replacement parts are available.

Model	Description	Inside Diameter Range	Outside Diameter Range
LA-3600	Laser Alignment Gage	11" - 55"	8" - 50"



Ovality Gage

Ovality gages are designed to check the out-of-round condition of tubular goods prior to processing. Gagemaker's OG-9800 series offers diameter adjustability within a size range. Stabilizing rollers are adjustable for diameter as well as for alignment to the centerline.

Model	Description	Range
OG-9801	Ovality Gage, pipe ovality	2" - 6"
OG-9802	Ovality Gage, pipe ovality	6" - 10"
OG-9803	Ovality Gage, pipe ovality	10" - 14"





Shoulder Location Gages

Depth Gages

Our digital depth gages inspect the location of internal and external shoulders and grooves from the face of pin and box connections or other datum surfaces. The DG-1000 Series is available with the standard base, a 12" base, and a 20" base. These gages are available in ranges: 0"-8", 0"-12", 0"-18", and 0"-24".

The standard gage (DG-1000 Series) is supplied with a 7" extension arm and a 0° and 45° contact point holder for use with any #4-48 threaded contact point (one .072" contact point (T072) supplied unless otherwise requested). Longer extension arms and other contact point configurations and adapters are available upon request. The 12" (DG-1200 Series) and 20" (DG-2000 Series) gages include one double sided blade contact instead of a contact point and a contact point holder.

Digital depth gages do not require a setting standard. The gage is preset to zero on any flat surface and then applied to the product. Actual length measurements display on the gage's digital readout.

Features

- Inspects internal and external shoulder and groove locations.
- Uses an interchangeable contact point or blade that can service many different applications.
- Inch/metric conversion with digital readout
- Digital readout with .0005"/.01 mm resolution and SPC Output



Model	Description	Range
Depth Gage with Digital Display (in/mm)		
DG-1008	Depth Gage w/ digital display (in/mm), .0005"/.01 mm resolution	0" - 8"
DG-1012	Depth Gage w/ digital display (in/mm), .0005"/.01 mm resolution	0" - 12"
DG-1018	Depth Gage w/ digital display (in/mm), .0005"/.01 mm resolution	0" - 18"
DG-1024	Depth Gage w/ digital display (in/mm), .0005"/.01 mm resolution	0" - 24"
Depth Gage with Digital Display and 12" Base (in/mm)		
DG-1208	Depth Gage w/ digital display (in/mm), .0005"/.01 mm resolution, 12" base	0" - 8"
DG-1212	Depth Gage w/ digital display (in/mm), .0005"/.01 mm resolution, 12" base	0" - 12"
DG-1218	Depth Gage w/ digital display (in/mm), .0005"/.01 mm resolution, 12" base	0" - 18"
DG-1224	Depth Gage w/ digital display (in/mm), .0005"/.01 mm resolution, 12" base	0" - 24"
Depth Gage with Digital Display (in/mm) and 20" Base (in/mm)		
DG-2012	Depth Gage w/ digital display (in/mm), .0005"/.01 mm resolution, 20" base	0" - 12"
DG-2018	Depth Gage w/ digital display (in/mm), .0005"/.01 mm resolution, 20" base	0" - 18"
DG-2024	Depth Gage w/ digital display (in/mm), .0005"/.01 mm resolution, 20" base	0" - 24"
Depth Gage Accessories		
DG-1000-R7	7" Extension Arm	
DG-1000-R16	16" Extension Arm	
DG-1000-R24	24" Extension Arm	
DG-1000-R36	Stabilizer for larger diameters	36" & Larger
DG-1000-BPA	DG-1000 Base Plate Assembly	
DG-1212-DF	Shoulder Location Double Foot for DG-1208 and DG-1212	
DG-1218-DF	Shoulder Location Double Foot for DG-1218 and DG-1224	
DG-B-812	Blade Contact for 8 and 12 inch ranges for DG-1200/2000	8 & 12
DG-B-1824	Blade Contact for 18 and 24 inch ranges for DG-1200/2000	18 & 24
DG-DSB-812	Double Sided Blade Contact for 8 and 12 inch range DG-1200/2000	8 & 12
DG-DSB-1824	Double Sided Blade Contact for 18 and 24 inch range DG-1200/2000	18 & 24
DG-GV-812	Groove Locator, .100" thick for DG-1008 and DG-1012	8 & 12
DG-GV-1824	Groove Locator, .100" thick for DG-1018 and DG-1024	18 & 24
DG-P45-812	45° Point Holder for DG-1008 and DG-1012	8 & 12
DG-P45-1824	45° Point Holder for DG-1018 and DG-1024	18 & 24

Torque Shoulder Gages and Standards

The TS-4001 Torque Shoulder Gage accurately measures the distance between the primary and secondary torque shoulders on both internal and external threaded connections. Used industry wide to measure the shoulder-to-shoulder distance on premium tool joints and the face-to-seal location on premium couplings, the Gagemaker TS-4001 is also perfectly suited to locate grooves from various datum surfaces.

The TS-4001 requires a setting standard. The gage is preset to the desired dimension and deviation is read from the gage's dial indicator.

One contact point included, customer to specify. One taper block is supplied based on customer's taper specification. Additional contact points and taper blocks sold separately.

Features

- Inspects internal and external shoulders along with groove locations
- Uses an interchangeable contact point that can service many different applications

Model	Description	Range
TS-4001	Shoulder Depth Gage (Specify Taper)	2 3/8" & Larger
TSS-4000	TS-4001 Setting Standard	

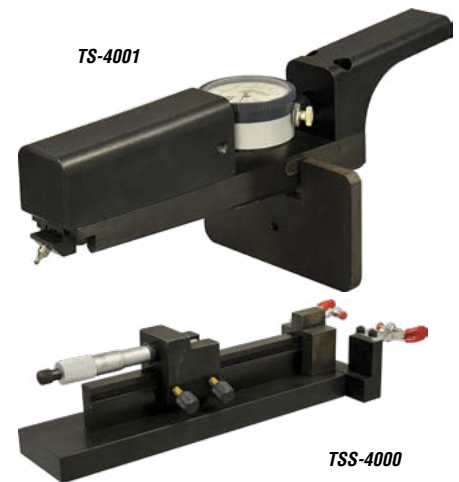

Thread Data

Thread Data Chart

The Gagemaker API Thread Data Chart provides critical thread data per API Specification 5B.

Model	Description	Connections
Thread Data Chart	API Tubing and Casing Thread Dimension Slide Chart	2 3/8" - 20" 8 Round, LTC, STC 4 1/2" - 20" Buttress

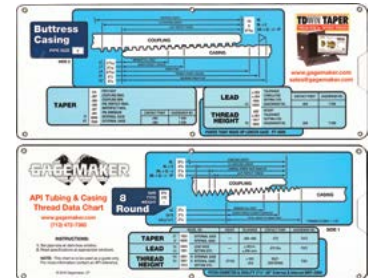

Thread Data Chart



Specialty Items

Coupling Alignment

The Coupling Alignment gage ensures that the threads on both ends of the coupling are properly aligned with each other. Coupling alignment inspection is mandated by the 16th edition of the API 5B.

Model	Description	Range
CA-9001	Coupling Alignment Gage	2 $\frac{3}{8}$ " & Larger

Internal Deep Reach Bore Gages

The DB series of gages are internal deep reach bore gages. Internal deep reach bore gages allow the difficult measuring of pitch diameter deep inside a small diameter product. One set of contact points and one set of extension rods (total range 15.25") are included.

Model	Description	Min. Bore	Travel
DB-1012	Internal Deep Reach Bore Gage, 12" reach	2.1"	.75"
DB-1018	Internal Deep Reach Bore Gage, 18" reach	2.1"	.75"
DB-1024	Internal Deep Reach Bore Gage, 24" reach	2.1"	.75"

Pit Depth Gages

The PD-3000 series of gages inspect the depth of surface pitting on tubular goods. The gage also accepts other types and sizes of contact points for use in other applications, such as groove and thread depth inspection. Select the PD-3000 gage model based on the type of indicator required.

Model	Description	Travel
PD-3003	Pit Depth Gage, AGD #1, 0-100	.250
PD-3004	Pit Depth Gage, AGD #2, 0-100	.450
PD-3005	Pit Depth Gage w/ Flat Base, AGD #2, 0-100	.450
PD-3006	Pit Depth Gage w/ 6" Long Flat Base, AGD #2, 0-100	.450
PD-3007	Pit Depth Gage w/ 6" Long V Base, AGD #2, 0-100	.450
PD-3000BF	Pit Depth Flat Base Only	
PD-3000BV	Pit Depth V Base Only	
PD-3000BF-6	Pit Depth 6" Long Flat Base Only	
PD-3000BF-10	Pit Depth 10" Long Flat Base Only	
PD-3000BV-6	Pit Depth 6" Long V Base Only	

Power Tight Make-up Gage

The Power Tight Make-up Gage, PT-4000, adjusts to determine the proper make-up location of API couplings.

Model	Description	Range
PT-4000	Power Tight Make-up Gage	All Sizes

Standoff Gages

The ST-7001 measures variation in ring and plug gage standoff on rotary shouldered connections. The ST-7001 is supplied with a setting standard. The ST-7002 is set on any qualified surface.

Model	Description	Range
ST-7001	Pin Standoff Gage w/ Setting Standard	.615" - .635"
ST-7002	Box Standoff Gage to measure plug stand-in, .0005" resolution	0" - .01" stand-in
STS-7001	Setting Standard Replacement, .625" width	

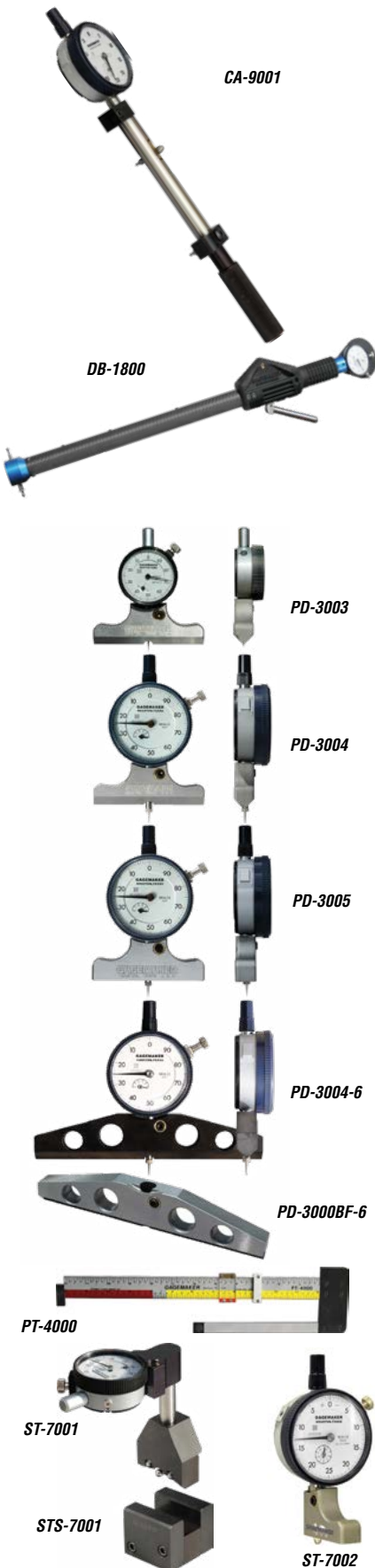

Wall Thickness Gages

The WT-9000 series of gages measures wall thickness at specific distances from the end of the pipe. Specify the distance from the end of the pipe to the measuring plane when ordering.

Model	Description	Range
WT-9001	Wall Thickness Gage	2¾" - 4½"
WT-9002	Wall Thickness Gage	4½" - 9¾"
WT-9003	Wall Thickness Gage	4½" - 13¾"



WT-9001

Gage Storage Cases

Gagemaker promotes three types of gage storage cases in various sizes- heavy-duty, standard, and wooden. The two plastic types are constructed of durable ABS molded plastic material.

The PEL Series of heavy-duty plastic cases, manufactured by Pelican, are extremely sturdy and can be used to ship and store gages. These cases not only provide extra protection for gages, but they are watertight, airtight, dustproof, and crushproof.

The CASE Series are our standard plastic cases. They are constructed from durable ABS molded plastic. These cases are low impact resistant and lightweight.

The WOOD Series of cases is our line of rugged, handcrafted wooden cases. If necessary, wooden cases can be customized to your specifications.

All storage cases are available with foam inserts at additional cost. Also, foam inserts can be custom cut for any of our products. Custom cutting of foam for cases is priced on an hourly basis. Please call for a quotation.



PEL Series



WOOD Series



CASE Series

Model	Inside Measurements	Model	Inside Measurements
PEL-1400	12¼" X 9¼" X 5¼"	PEL-1600	22" X 17" X 8"
PEL-1450	15" X 10¾" X 6"	PEL-1700	36" X 13½" X 5"
PEL-1500	17¾" X 11¾" X 6¾"	PEL-1750	50¾" X 13½" X 5"
PEL-1550	19¾" X 13¼" X 7¾"		

Model	Inside Measurements	Model	Inside Measurements
CASE-1	16" X 11" X 3"	CASE-5	21½" X 14½" X 6⅝"
CASE-2	14" X 10" X 3"	CASE-6	8⅝" X 5⅝" X 3⅝"
CASE-3	9" X 12½" X 2¾"	CASE-7	21" X 14" X 6"
CASE-4	7" X 4" X 2"		

Model	Inside Measurements	Model	Inside Measurements
WOOD-A	54" X 17" X 3½"	WOOD-J	27" X 10" X 3.5"
WOOD-B	48" X 10" X 3½"	WOOD-J-1	27" X 9" X 3½"
WOOD-B-1	46" X 26" X 3½"	WOOD-K	26" X 15" X 3½"
WOOD-C	44" X 8" X 3½"	WOOD-L	25" X 10" X 3½"
WOOD-D	42" X 24" X 3½"	WOOD-M	22" X 12" X 3½"
WOOD-E	42" X 10" X 3½"	WOOD-N	22" X 8" X 3½"
WOOD-F	35" X 12" X 3½"	WOOD-O	21" X 8" X 3½"
WOOD-G	34" X 10" X 3½"	WOOD-P	17" X 10" X 3½"
WOOD-H	34" X 8" X 3½"	WOOD-Q	15" X 15" X 3½"
WOOD-I	33" X 21" X 3½"		



Foam Inserts



Custom Cut Foam



CUSTOMER SERVICE

For any questions, quotations, requests, technical support or any other information, please contact one of our representatives at any of the following:

Address: Gagemaker LP
712 East Southmore Ave.
Pasadena, TX 77502-110

Fax: 713-472-7241

Phone: 713-472-7360
Monday - Friday : 8am - 5pm CST

Website: <http://www.gagemaker.com>

E-mail: gagemaker@gagemaker.com or sales@gagemaker.com

TECHNICAL SUPPORT

Gagemaker technical support is available through contacting our friendly customer service department at any of the above options.

QUOTATIONS

Quotations are valid for 30 days after the date on the quote. Please refer to the customer service section for contact information for quotations.

PICK UP/WALK-IN/COLLECTION

Some of our products are available for pick up directly from our Pasadena facility. Please contact us if you would like a direct pickup. Notify us of your intentions to pick up products a **minimum of 2 hours** in advance of your arrival.

SHIPPING POLICY

Unless otherwise requested, Gagemaker ships once an order is complete. If you would like a partial order shipped, please contact customer service or indicate when ordering.



HANDLING CHARGE

Gagemaker will charge a \$10 (USD) handling fee for ALL orders on products invoiced for LESS than \$50 (USD). No fee will be applied to orders invoicing for over \$50 (USD).

RETURN POLICY

Gagemaker requires a 15% restocking fee on all non-defective returns, except for MIC TRACs (either the MT-3000 or MT-4000) which will be charged a 20% restocking fee. Items not listed in our catalog are not returnable.

Returns may be accepted up to **30 days** after the date of the invoice. Please return products to the address listed in our Customer Service section. Please contact Gagemaker for a Return Goods Authorization (RGA). Contact our Customer Service for any questions regarding your return. Special or custom orders cannot be returned.

Defective products must be returned **15 days** from the date of receipt in order to be eligible for a full refund. Defective products are not subject to any restocking fee. For defective product information, please see our Product Warranty section.

PRODUCT WARRANTY

Gagemaker warrants its products to be free from defects in material and workmanship under normal operating conditions for 12 months from the date of shipment. This warranty is limited to repairing, or at Gagemaker's option, replacing any product which is proven to have been defective at the time it was shipped and/or suffered damage during shipping, provided buyer has given Gagemaker written notice of any such claimed defect within 15 days of receipt. Any defective product must be properly packed and shipped to the Gagemaker factory in Pasadena, Texas USA. This warranty applies to all products when used in a normal industrial environment. Any unauthorized tampering, misuse or neglect will make this warranty null and void. Under no circumstances will GAGEMAKER or any affiliate have any liabilities for loss or for any indirect or consequential damages. The foregoing warranties are in lieu of all other warranties expressed or implied, including but not limited to, the implied warranties of merchantability and fitness for a particular purpose.

Return products for repair or calibration to:

**Gagemaker LP
712 East Southmore Ave.
Pasadena, TX 77502-110**

Index

	Page		Page
B			
Bench Calibrator Gages	93, 136		
Box Seal Gages	64		
BR-2001	66, 127		
Buttress Groove Width Gages	146		
Buttress Runout Gage	66, 127		
Buttress Tooth Width Gages	146		
BX Series Gages	137		
BX-1000	137		
BX-Dog Bone Paddle Gage	137		
BX-Groove Profile & Width GO/NO GO Gage	138		
BXG-1000	137		
C			
Calibration & Repair Services	98-101		
CA-9001	150		
CAL-PAK	92, 136		
CamLock Micrometers	139		
CG-1001	93, 136		
CL-1000 Series	139		
Contact Points	124-125		
Contact Points, Rotary Shouldered Connections	47, 49, 51, 124-125		
Contact Points, Straight Threads	15, 17, 124-125		
Contact Points, Tubing and Casing Gages	29, 33, 124-125		
Coupling Alignment Gage	150		
CRC-MT3000	92, 136		
CRC-MT4000	92, 136		
Crest Diameter and Ovality Gages	30, 58-59, 104		
Crest Diameter and Ovality Gage Standards	30-31, 106-109		
Custom Gages	80-81		
D			
DB-1800, DB-2400	150		
Deep Bore Internal Functional Size Gage	116		
Depth Gages	60-61, 148		
Depth Gage Accessories	148		
DG-1000	60-61, 148		
Dial Indicators	130-131		
Digital Indicators	131		
DPG-6500	116		
E			
ET-7000 Series	32, 50, 115		
External Functional Size Gages	12, 116		
External PD Thread Inspection Gages	14, 114		
External Pitch Diameter Gages	14, 114		
External Taper Gages	32, 50, 115		
External Thread Height Gages	18, 34, 52, 122		
F			
Face Groove & Hole Location Gages	137		
Face Groove & Hole Location Setting Masters	137		
Frame Style Setting Standards for MRP® Series (non-5000)	108-109		
Functional Size Gages, Straight	12, 116		
Functional Size Gages, Tapered	110		
G			
Gage Storage Cases	151		
Groove Width Amplifier Gages	139		
GW-1000 Series			
I			
Indicators		130-131	
Indicator Replacement Parts		131	
Indicator Standoff Gage		150	
In-House Precision Gage Calibration System		90-91, 134	
Insert Identifiers		44, 127	
Internal Deep Reach Bore Gages		150	
Internal Diameter/Groove Gages		146	
Internal Functional Size Gages		12, 116	
Internal PD Thread Inspection Gages		14, 114	
Internal Pitch Diameter Inspection Gages		14, 114	
Internal Taper Gages		32, 50, 115	
Internal Thread Height Gages		18, 34, 52, 122	
IT-5100 Series		146	
IT-5104-RSC		47, 113	
IT-6000		32, 50, 115	
IT-6001 & Replacement Parts		32, 115	
L			
Laser Alignment Gage		63, 147	
Lead Gage Setting Standards		16, 29, 49, 121	
Lead Gages		16, 28, 48, 120	
LG-5003 Series		16, 28, 48, 120	
LG-6001 Series		16, 28, 48, 120	
LG-6002 Series		16, 28, 48, 120	
LPB Templates		46, 112	
LPP Templates		46, 112	
Location Profile Templates		46, 112	
LS-1000 Series		121	
M			
MIC TRAC™ 3000		88-89, 132	
MIC TRAC™ 3000 Accessories		92, 136	
MIC TRAC™ 4000		90-91, 134	
MIC TRAC™ 4000 Accessories		91-92, 135-136	
MIC TRAC™ Calibration Chart		84-85	
MIC TRAC™ Setting Blocks		133	
MIC TRAC™ System Options		92, 136	
MM-0-6		76, 143	
MRP® Frame Style Standards (excluding MRP-5000)		108-109	
MRP® Rod Style Standards (excluding MRP-5000)		30-31, 106-107	
MRP-1000, MRP-1500		30, 58, 104	
MRP-2000, MRP-2500		30, 58-59, 104	
MRP-3000, MRP-3500		59, 104	
MRP-5000		110	
MRP-5000 Frame Style Standards		111	
MRP-5000 Replacement Parts		110	
MRP-5000 Thread Rolls		110	
MRP® Pitch Diameter and Ovality Gages		30, 58-59, 104	
MRP® Replacement Parts		105	

M (Cont.)

MT-4-USB

O

Ovality Gage

Ovality Gage (MRP)

P

PD-3000 Series

PD-6000 Series & Replacement Parts

PD-8000 Series

PD-8000-RSC Series

PG-6000 Series

Pin Nose Seal Diameter Gages

Pin Seal Diameter Gage Standoff Plates

Pit Depth Gages

Pitch Diameter Gages, Rotary Shouldered Connections

Pitch Diameter Gages, Straight Threads

Pitch Diameter Location Templates

Pitch Diameter Rod Standards for RSC gages

Pipe Straightness Gages

PN-3000 Series

Power Section Gages (Stator, Rotor Maj./Min. Dia.)

Power Tight Make-up Gage

Premium Connection Standards

PT-4000

R

R & RX- Dog Bone Paddle Gage

Repair Services

RG-7000 Series

Rod Style Setting Standards for MRP® Series

Rotor Major Diameter Gages

Rotor Minor Diameter Gages

Rotor Saddle Gage

Rod Style Setting Standards for RSC gages

R-RX-Groove Profile & Width GO/NO GO Gage

Rotary Shouldered Connections Solutions

S

Saddle Gage

SBG-5000A, SBG-5000D, SBG-5000E

SE-1000

SG-8001

Shoulder Location Gages

Shop Floor Gage Setting and Part Measurement System

Smaller Diameter Thread Inspection Gages

SPG/SPA Pitch Diameter Contact Arms

SPG/SPA Pitch Diameter Contact Points

SPG-6000

SPG-6000 Thread Rolls

Squareness Gage

SQ-1636, SQ-1648

ST-7001

Standoff Gage and Setting Standard

Page

92, 132

147

30, 58-59, 104

150

14, 114

14, 114

47, 113

12, 116

64-65, 144-145

145

150

47, 113

14, 114

46, 112

113

62-63, 147

64-65, 144-145

72-77, 140-143

150

67

150

138

98-101

12, 116

106-107

76-77, 142

76, 143

143

113

138

38-39

62, 147

72, 140

62, 147

62, 147

60-61, 148-149

88-89, 132

118

119

119

118

118

62, 147

62, 147

150

150

S (Cont.)

Straight Thread Insert Identifiers

Straight Thread Inspection Solutions

Straight Edge Gage and Standard (SE-1000) Gages

Stator Bore Gages (SBG-5000 Series)

Stator Bore Shoes

Stator Bore Standards

Storage Cases

T

Taper Gages

Tapered Insert Identifiers

TDWIN™

TDWIN Taper™

TH-3000 Series

Thread Data Chart

Thread Height Contact Points, Rotary Shouldered Conn.

Thread Height Contact Points, Tubing and Casing

Thread Height Gages (External and Internal)

Thread Height Gage Standards

Thread Height Gage Standards, Rotary Shouldered Conn.

Thread Height Gage Standards, Tubing and Casing

Thread Form Profile Gages

Thread Form Profile Overlays

Thread Form Profiles, Rotary Shouldered Connections

Thread Form Profiles, Straight

Thread Form Profiles, Tubing and Casing

Thread Rolls

Thread Rolls, MRP-5000

T-MIC™

Tooth Width Gages for Buttress

Torque Shoulder Gage & Standards

TS-4001

Tubing & Casing Inspection Solutions

TW-6001

W

Wall Thickness Gage

WT-9000 Series

Page

127

6-7

62, 147

72, 140

75, 141

73, 74, 140-141

151

32, 50, 115

44, 127

10-11, 128

26, 42-43, 129

18, 34, 52, 122

149

53, 123

35, 123

18, 34, 52, 122

35, 53, 123

53, 123

35, 123

19, 27, 45, 126

127

45, 126

19, 126

27, 126

13, 117

110

76-77, 142

146

61, 149

61, 149

22-23

146

151

151



Gagemaker LP

P.O. Box 87709, Houston, Texas 77287-7709

712 East Southmore Ave., Pasadena, Texas 77502

Phone: 713-472-7360 • Fax: 713-472-7241

Email: gagemaker@gagemaker.com or

sales@gagemaker.com

Web: www.gagemaker.com

Facebook: www.facebook.com/Gagemaker

Twitter: www.twitter.com/Gagemaker

GAGEMAKER

DETERCO, INC.
Quality Products and Services

sales@deterco.com www.DetercoOnline.com (713)-943-2721

www.gagemaker.com