

SMARTMARK[®] LASER PRODUCT CATALOG





Why MECCO®? Our vast industry experience means that whatever your needs - whether OEM, benchtop, or turnkey solutions - we deliver. Unlike other laser marking manufacturers, we listen to your challenges and devise solutions tailored specifically to your needs.

Together, we forge a working partnership that saves you time, money and resources, so that you can focus on doing what you do best.

TABLE OF CONTENTS

03 The MECCO Experience	19 MECCOmark CO ₂ Laser
04 Choosing Your Laser	21 SMARTmark Green Laser
06 Integrating & Using Your Laser	23 SMARTmark UV Laser
07 Traceability for The Connected Factory	25 Class I Enclosures
08 Integrated Solution ETHERMARK	29 Integrated Vision
09 SMARTmark Laser Controller	30 Enclosure Options
10 Embedded Controller	31 Safety Seal
11 Software	33 Application Engineering
13 LightWriter by MECCO	34 Engineered Solutions
15 SMARTmark Fiber Laser	35 Our Process
17 SMARTmark Tiburon Laser	36 Support

MADE IN
THE USA

THE MECCO® EXPERIENCE INNOVATIVE RELATIONSHIPS, INNOVATIVE SOLUTIONS.

At MECCO®, we are powered by one word: innovation. We believe that in order to deliver the very best in industrial product marking and identification systems, we must provide relationships and solutions that are grounded in innovation.

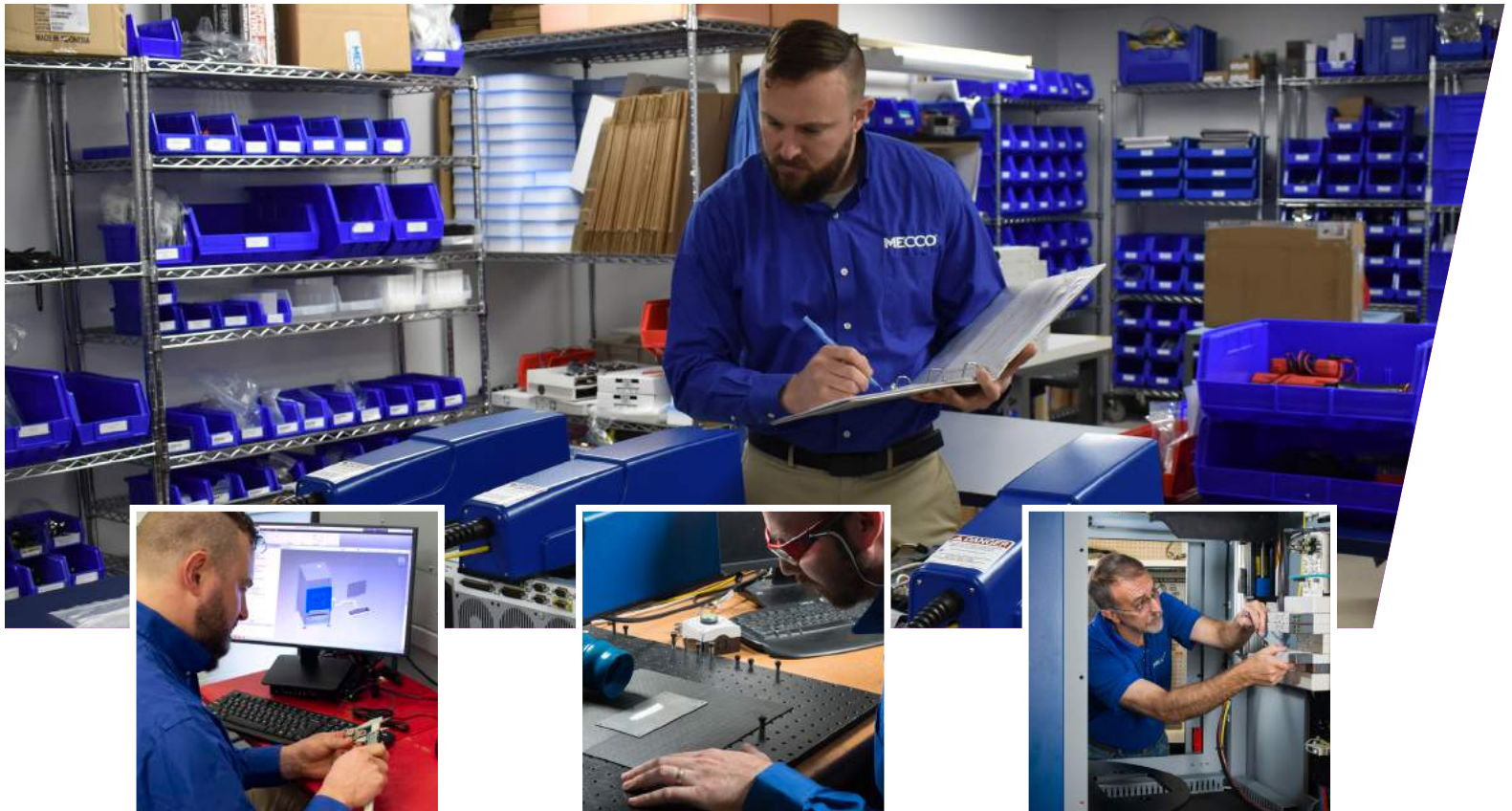

ENGINEER

TEST

BUILD

How do we do it? It all begins with our culture, one that is built around honest communication, win-win scenarios, and designing success. It comes to life through our quality-built equipment, responsiveness to your needs and engineered marking systems that can't be beat. You and your company gain when you choose The MECCO Experience.

www.mecco.com

ONE CLICK, ONE CALL GETS IT ALL

.....
When you work with us, we address your full-scale needs so that you don't have to turn to multiple suppliers. With just one call, we'll get it all and get it right. And with our steadfast emphasis on high quality manufacturing and integration, you can expect peace of mind every step of the way.

CHOOSING YOUR SMARTMARK® LASER MARKING SYSTEMS

 Configured and Custom Solutions

Simplified Marking And Real-Time Traceability

SMARTmark Systems are used to etch or engrave serial numbers, barcodes, and other information for the purpose of product identification and traceability. Our standard and customized laser equipment – focused on delivering “Simplified Marking And Real-Time Traceability” – are most often chosen by customers because of the quality of the equipment and the mark it produces.

 OEM



 Benchtop



FIBER LASER

1064 nm wavelength: Fiber lasers use an optical fiber doped with rare earth elements such as ytterbium. They are versatile marking systems that mark the widest variety of parts.

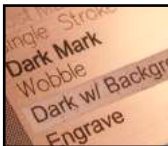
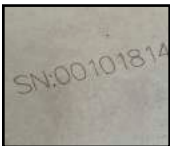

GREEN LASER

532 nm wavelength: A pulsed green fiber laser that operates at a shorter wavelength, ideal for soft or heat-sensitive materials, while 20W of power makes it faster than other laser systems.



TIBURON LASER

1064 nm wavelength: A Diode-pumped laser with patented diodes pumping YAG Crystal, using high peak power, which is ideal to mark plastics and remove paint or anodization.

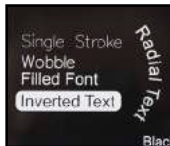

UV LASER

355 nm wavelength: Damage-free, pulsed UV fiber laser gently marks even the most delicate components, such as medical devices or electronics.



CO₂ LASER

10600 nm wavelength: The CO₂ Laser is a carbon dioxide continuous wave laser that is ideal for marking wood, glass, plastic, and rubber.



LIGHTWRITER™ BY MECCO® FIBER LASER

1064 nm wavelength: A fiber laser in a Class I enclosed workstation, the all-in-one LightWriter offers built-in safety and efficiency for an array of applications.

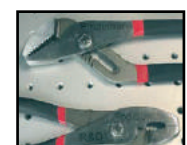

LASER MARKING AND ITS BENEFITS



Lasers create a permanent and durable mark using a variety of application methods such as engraving, carbon migration, annealing, layer removal, and discoloration. Manufacturers choose laser over other technologies for its speed, high resolution, high contrast, no contact, and minimal consumables.

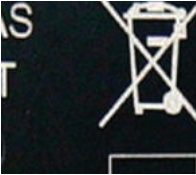

Additional benefits of laser marking include part identification, branding, and cradle-to-grave traceability. Direct part marking with a laser marking machine delivers durable, readable, high quality marks that can provide your operation with:

- » Greater operational efficiency and productivity with less waste and downtime
- » Improved visibility and accountability through the supply chain
- » Minimized costly threats such as quality and counterfeiting issues
- » Compliance with various industry regulations



LASER SAFETY

Avoid eye or skin exposure to direct or scattered radiation from this product. Consult with one of our laser product engineers to discuss safety measures for your facility. Class I laser-safe enclosures and integration options are available in a range of sizes. For a Class IV workstation, laser-safe eye protection or shields must be used.

CHOOSING A LASER TYPE

Choosing a laser begins by picking the source that works best for your application.

Material (Type of Mark)	Fiber	Tiburon	CO2	Green	UV
Steel (Anneal)	★	✓	✗	✓	✗
Steel (Etch)	★	✓	✗	✓	✗
Steel (Engrave)	★	✗	✗	✗	✗
Copper (Dark Mark)	✓	★	✗	★	✗
Copper (Etch/Cut)	★	✗	✗	★	✗
Aluminum (Etch)	★	✓	✗	✓	✗
Aluminum (Engrave)	★	✗	✗	✗	✗
Anodized Aluminum	✓	★	✓	✓	✓
Plastic	✓	★	✓	★	★
Ceramic	★	✗	✗	✓	✓
Brass	★	✓	✗	★	✗
Glass	✗	✗	★	✗	✓
Cardboard	✗	✗	★	✗	✓
Wood	✗	✗	★	✗	✓

★ Best Option ✓ Will Mark ✗ Will Not Mark

INTEGRATING & USING YOUR LASER MARKING SYSTEM

Your Guide to Positive Outcomes 'Beyond the Mark'

We believe that one size doesn't fit all. So when we work together, we don't start by pushing a product. Instead, we work to find the right solution for you by addressing high-level issues:

- » What do you need your traceability system to do?
- » How will it integrate with the rest of your business?
- » How does it need to be used to achieve optimal results?

SOLUTIONS DESIGNED FOR YOU

It is with this methodology that we're able to provide a solution that is designed to work for you, setting up your long-term success.

Starting with traceability and how it integrates with your operations leads us down a better path to product selection. As we discuss how data will be sent back and forth, we can start to map out the needs of your laser marking system.

Manufacturers have relied on us to collaborate, problem-solve, and transform what's possible in marking and traceability ever since 1889. You'll find that when you talk, our team listens. Then we foster working relationships that save you time, money, and resources – so you can focus on doing what you do best.

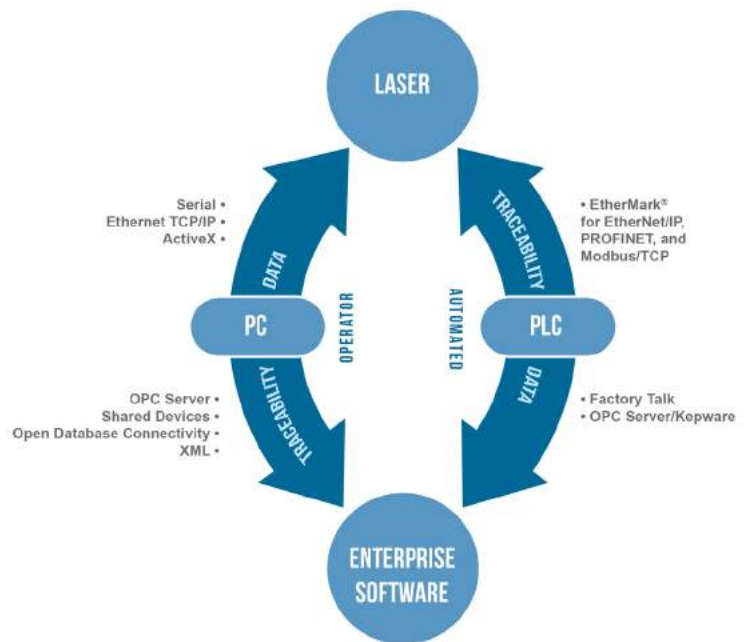

OPERATOR VS AUTOMATED: THE TWO WORLDS OF LASER INTEGRATION

In typical manufacturing environments, a laser is either communicating with a PLC or a PC to transmit or receive traceability information.

In both environments, the communication protocols can vary depending on manufacturing systems. MECCO's traceability solutions are easily configurable and flexible for integration to the manufacturing floor and the enterprise software.

SUPPORTED COMMUNICATION PROTOCOLS FROM LASER MARKING SYSTEM(S)

To PC:

- Serial
- Ethernet TCP/IP
- ActiveX

To PLC:

- EtherNet/IP
- PROFINET
- Modbus

SUPPORTED APPLICATION INTERFACES TO ENTERPRISE SOFTWARE

From PC:

- OPC Server
- Shared Drives
- ODBC
- XML

From PLC:

- Factory Talk
- OPC Server

TRACEABILITY FOR THE CONNECTED FACTORY

Connect Track-And-Trace with Your Enterprise

To overcome today's industrial challenges, manufacturers need to work smarter by connecting the factory. They need to increase efficiency, reduce costs, and enhance quality. All of these goals can be accomplished using an integrated track and trace system.

Most factory equipment like robotics and vision systems are controlled through programmable logic controllers (PLCs). These systems communicate directly with the PLC using EtherNet/IP to automate processes in assembly lines.

Laser marking part information in barcode or human readable form is the critical component for achieving traceability, but it has historically required proprietary Application Programming Interfaces in order to communicate. This resulted in **30 to 80+ hours** of custom programming.

OPTIMIZING CONNECTIVITY TO ENSURE DATA INTEGRITY

EtherMark® provides direct communication from the PLC to the laser marking device. Now that laser marking equipment, via EtherMark, is connected to the factory floor, it becomes easier to implement a traceability system and obtain the benefits of cost reduction and increased efficiencies.

This EtherMark technology enables much faster initial deployment, simpler maintenance and fewer potential points of failure in communication. As an ODVA certified device, Add-On Profiles and Add-On Instructions **reduce the programming time from 30+ hours to as little as 8 minutes.**

CONNECTIVITY IN THE AUTOMATED FACTORY

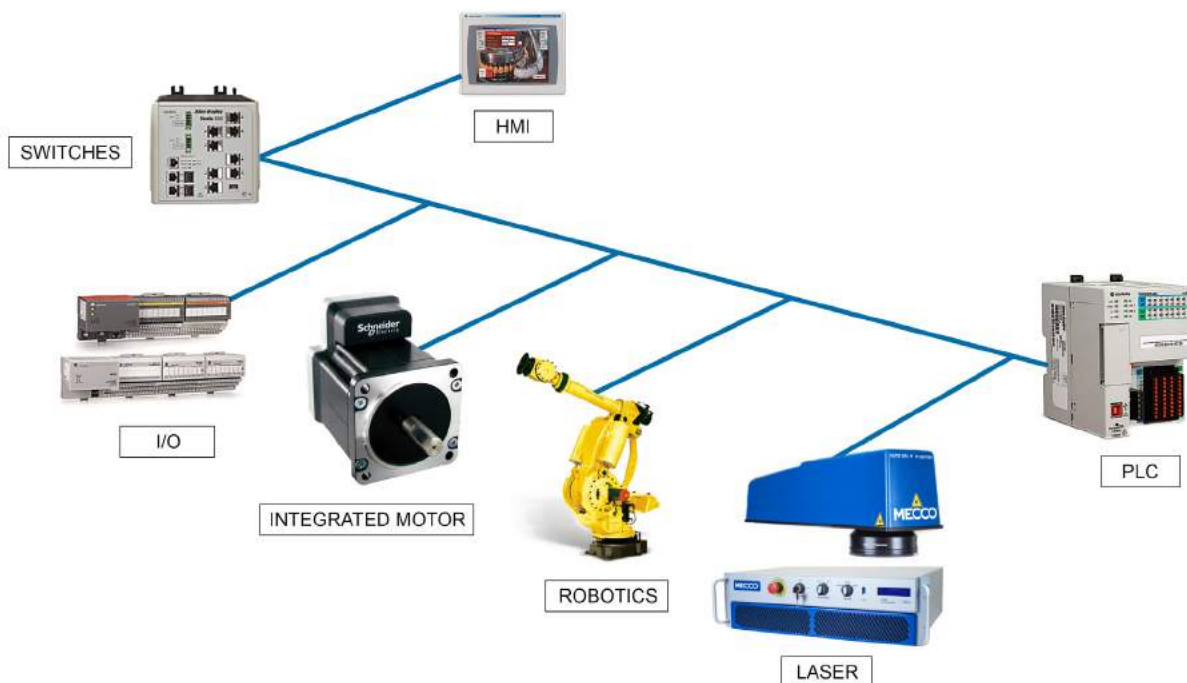

INTEGRATED SOLUTION ETHERMARK®

EtherNet/IP™

PROFINET

Modbus

Do you need to push any sequence of data, even if non-incremental, to your marker?

EtherMark is a patent-pending technology solution that facilitates integration of marking systems into factory automation networks using Ethernet-based industrial protocols like EtherNet/IP™, PROFINET, and Modbus. MECCO developed this integration architecture with embedded control technology in order to save manufacturers time and money by eliminating the need for custom programming of programmable logic controllers (PLCs), which was previously required in the laser marking industry.

Traditional marking systems employ vendor-specific proprietary APIs (Application Programming Interfaces). These interfaces require the PLC programmers to learn a proprietary command set and create custom code to perform basic marking operations.

EtherMark allows factory floor PLCs to use their Ethernet-based industrial protocol to control part marking systems' operations and traceability data management simplifies the communication process to only one command by the PLC for marking a job file.

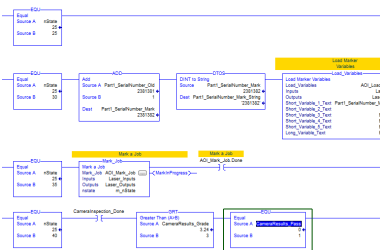

LADDER LOGIC

Add-on instructions simplify programming by allowing a user to drag and drop all of the typical commands to the unit (e.g., load job, load text, mark job).



OBJECT MODEL

EtherMark provides simple Allen-Bradley PLC Registers (Tags), which control or report the behavior of various functionality within the laser marking unit. Inputs allow you to supply settings like X and Y offsets, specify job file names and strings of information, while outputs report mark cycle time and machine status.



ADD-ON PROFILE

This feature allows plug and play compatibility between MECCO marking devices and Allen-Bradley PLCs.

Traditional Integration

Integrating a traditional marking system has always been a complex process to allow proprietary software to communicate with the rest of the production floor.

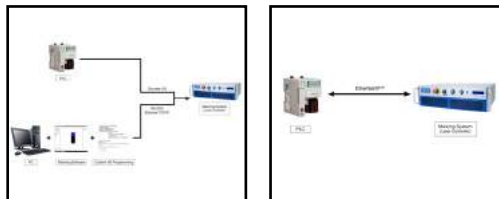

EtherMark® Integration

EtherMark removes the need for custom programming by providing object model interfacing to all of our marking products.

NETWORK & HARDWARE SPECIFICATIONS

- Connection:** 10/100 Mbps Ethernet standard RJ45 port, to network and PLC
- IP Address:** Manually set fixed IP configured by user
- Firmware:** Flash firmware upgrade via Ethernet or USB
- Control:** Supervisory control of LEC Laser Marker
Supervisory control of Couth Dot Peen Marker
- Barcoding:** Laser: Capable of 3000 characters in a 2D barcode with string concatenation
Dot Peen: Capable of up to 75 characters in a 2D barcode

RA Technology Partner
A ROCKWELL AUTOMATION PARTNER

SMARTMARK® LASER CONTROLLER

Functionality and Connectivity for SMARTmark Lasers

The laser controller for the SMARTmark line of laser marking systems contains the operational control switches as well as status/indicator lights for ease of troubleshooting. Inside the control box reside the main system control devices and power supplies.

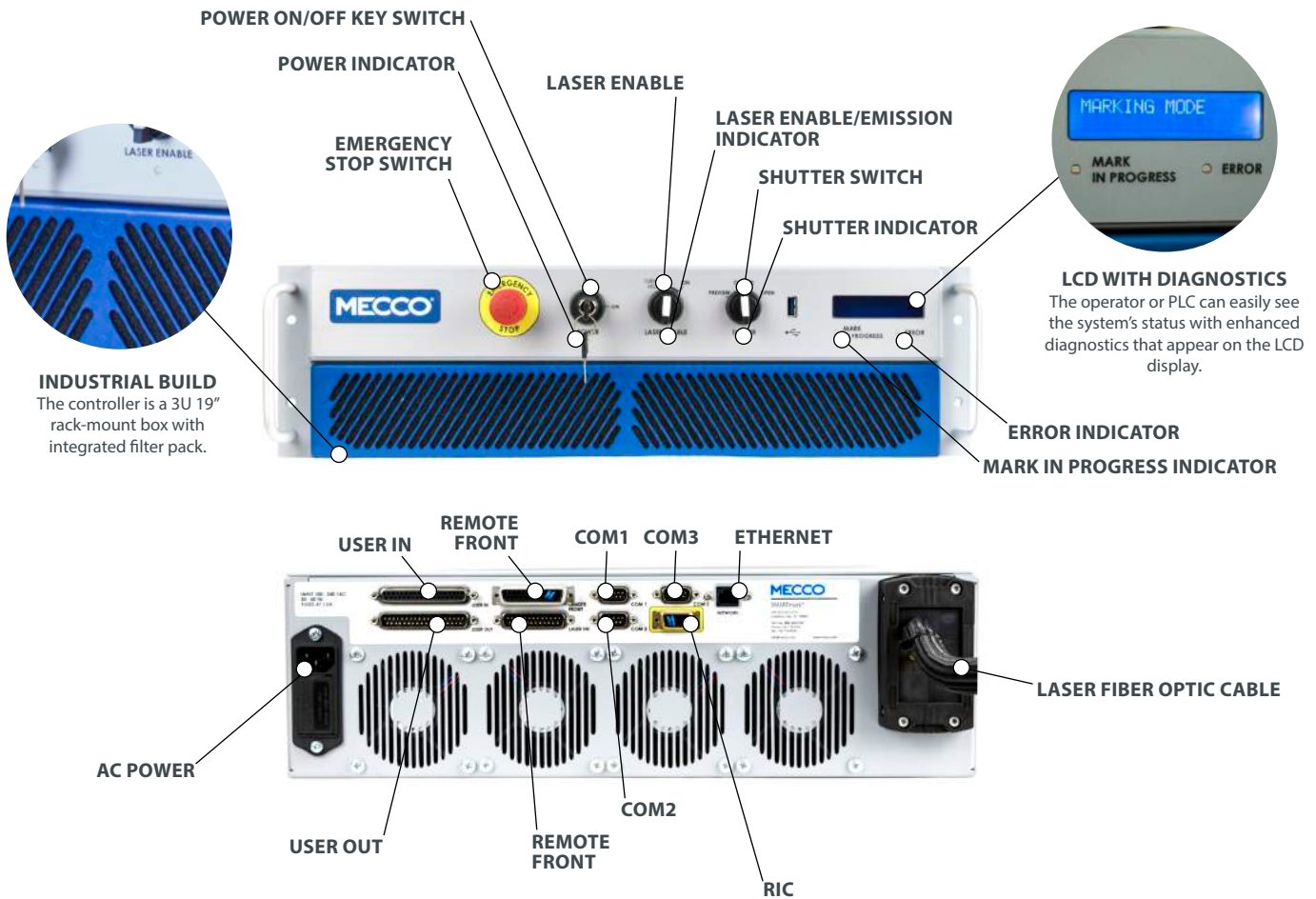

SMARTMARK® CONTROLLER SPECS

Laser Umbilical	Hard wired to laser rail to provide controls and power to laser resonator
Power Umbilical	Hard wired to laser rail to provide control wires to scanhead, safety shutter and lights
Controller Dimensions	20-50W: L 19.49" x H 5.17" x W 18.99" 100-200W: L 19.49" x H 11.9" x W 18.99"
Controls	LEC Embedded System Controller
Communications	Ethernet TCP/IP, EtherNet/IP™, PROFINET, Modbus TCP, RS232
Connectors	User In, User Out, Remote Front, Laser Int., COM1, COM2, COM3, RIC, NETWORK, NETWORK (Optional), AC Input

STANDALONE SOLUTION EMBEDDED CONTROLLER

The SMARTmark Laser controller's LEC card contains a fully integrated processor and operating system capable of operating in a fully independent stand-alone mode.

The embedded controller might be the best fit for you if you answer "yes" to the following questions:

- » Do you want to remove the PC from your shop floor?
- » Do you have a pre-defined job file to use repeatedly?
- » Do you need to mark incremental serialization or timestamps?

The number of jobs that can be saved is limited only by the available storage on either the built-in Flash memory, or an installed USB Flash drive. Individual jobs to be processed are accessed based on digital I/O signals or selected on a local pendant interface.

CONFIGURATION

The following figure illustrates the control architecture configuration possible in stand-alone mode. In addition to running jobs for the laser, standalone mode is capable of integrating with a button box and saving motion control commands to the LEC.

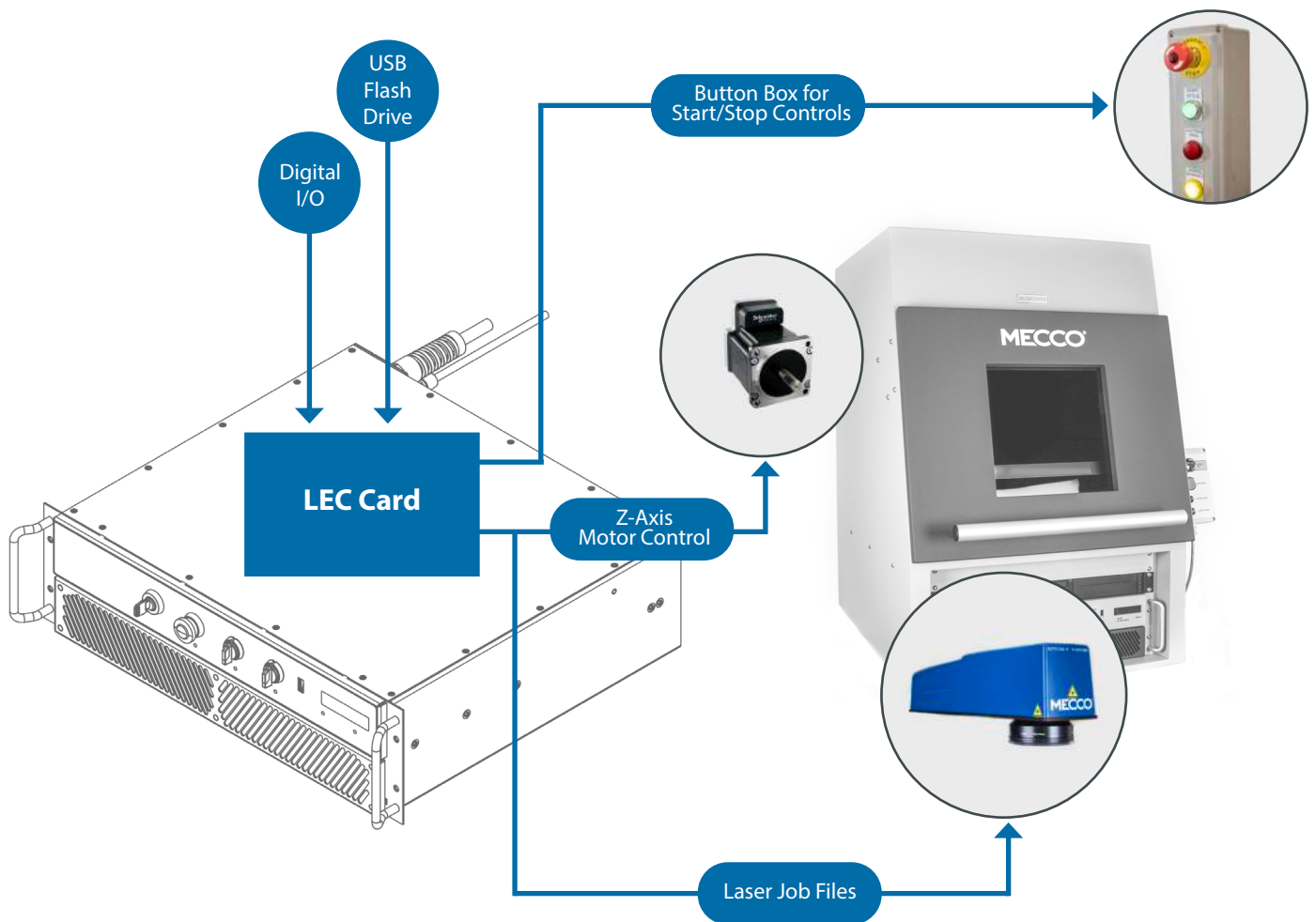

WINLASE® BY MECCO® LASER MARKING SOFTWARE

With MECCO's laser marking software, you will have the most innovative, easy-to-use laser marking interface available in the market today. Compatible with Windows XP®, Windows Vista®, Windows 7®, and Windows 10®, this system will provide networking and intelligent control that allows connection to multiple laser systems from one PC.

Software might be the best fit for you if you'd answer "yes" to the following questions:

- » Is your product flow constantly changing?
- » Do you only mark static or aesthetic marks?

MECCO's software provides a robust array of capabilities to make the marks you need, from fonts to barcoding to motion control.

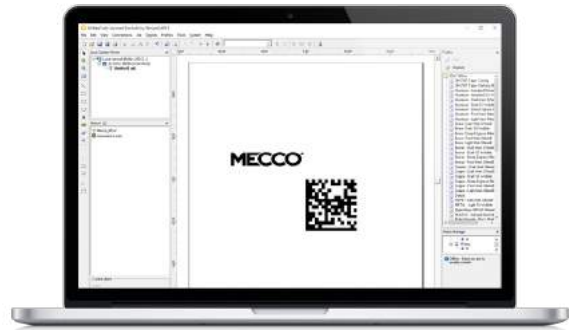

FEATURES



Graphics File Importing

SMARTmark Laser Marking Software can import DXF, AI, CDR, PLT, BMP, JPEG, GIF, TIFF, PNG, and many other file types. Graphics can be moved, scaled, filled, rotated and aligned in our simple Windows graphic user interface (GUI).



Laser Markable Fonts

Any TrueType font that is installed on the PC can be used within the laser marking software. These text objects can be utilized to create serial numbers, date and time codes, and shift or machine IDs, which can be marked in a straight line, radially, vertically, or even circumferentially.



External Control

The system and software can be controlled from external systems such as PLCs via RS-232, TCP/IP, and Profibus. A built-in COM automation server allows for rapid development of custom GUIs. Pendants are also available for simplified handheld local control when running in standalone mode without a PC. The software can be programmed to control external devices via I/O objects.



Barcoding

SMARTmark software offers the ability to mark a wide range of 1D and 2D bar codes, and editing the code's overall size, cell size, line spacing, inversion, and shape is made easy with our user interface. Includes the most commonly used options, such as:

- 1D:** UPC/EAN/JAN, Codabar, Interleaved 2 of 5, Code 39, Code 128, Code 93, Pharmacode, GS1 Databar
- 2D:** Data Matrix, QR Code, MicroQR Code, PDF417, MicroPDF, Optional for VeriCode®



Dynamic Logo / Text Filling Capabilities

There is no longer any need to change fill settings in external software. Our software is capable of filling any TrueType font text or logo with ease, providing options for the fill pattern, angle of fill, fill spacing, and multiple passes for ultimate flexibility and mark control.



WYSIWYG

Providing a simple Windows interface that allows the user to see exactly how the mark will look, SMARTmark software can be used to set up background templates that mimic the look, size, and shape of your parts. Click-to-drag, re-size, rotate, and many other easy-to-use editing features are available all within the software.

With MECCO's live 'Preview Mark' capability, you can view an outline of the mark right on your part and make edits in real time without having to enter and exit a preview mode. This tool helps to make job set-up easier in order to avoid mistakes.



System Security

There are three levels of password protection for users designated as Administrator, Technician, or Operator. Each level is completely customizable, allowing the Administrator to have full rights, the Technician to have limited rights, and the Operator to only have rights to open and process jobs that are pre-qualified.



Built-In Motion Control

SMARTmark Laser Marking Software can control up to 4-axis of motion simultaneously that can be programmed directly into each individual job, including rotary indexers, x-y tables, rotary tables, and z-axis. This allows for one-time pre-programming of movements and rotations of parts that will automatically run every time the job is opened.

CUSTOM GRAPHICAL USER INTERFACES

To determine if a custom GUI is necessary for your application, consider the following questions:

- » Is ease-of-use to the operator very important?
- » Is the laser mark data variable, requiring that it be sourced from, and/or written back to, a database?
- » Are there special database, serialization, and/or traceability requirements?
- » Is custom automation required?
- » Is vision inspection of the marking required?
- » Are there special marking requirements?

MECCO's custom GUIs are written using Microsoft Visual BASIC.NET, an industry standard development environment. The GUI is a Windows application, running in the Windows environment.

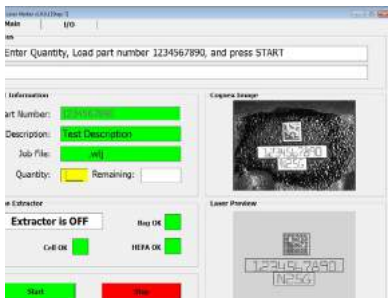

Custom GUI screen ready to start marking.

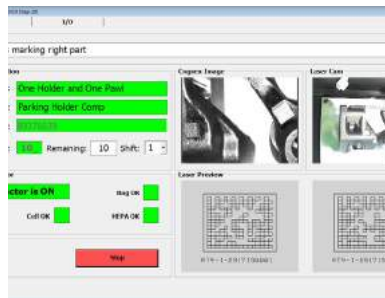

Screen can hide button when they shouldn't be used, such as hiding "Start" while marking is in progress.

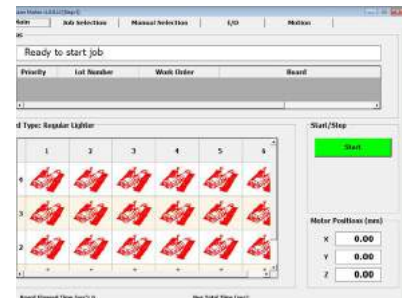

Custom GUI for an XYZ pallet of parts.

DATA CONNECTIVITY

MECCO has developed integration-ready packages for the following common methods of data connectivity.

GETTING DATA TO THE MARKER (PRE-MARK)

Open Database Connectivity (ODBC):

MECCO has used ODBC extensively to interface to Microsoft SQL Server, Access, and other common databases to allow the use of direct SQL queries and/or stored procedures to obtain custom marking information. The referenced database may be local to the marker PC, or hosted on the customer's network.

XML Web Services:

The user provides the mark information via their company intranet or the internet. The marker will derive mark data from the customer provided web service in XML form.

Drop Folder Polling:

The marker retrieves mark data from a customer provided text file. The customer specifies the drop folder, and provides the mark data in a file at the time of marking. The marking template and variable mark data are read from the file and used to configure the marker and mark the part.

OPC (Object Linking and Embedding for Process Control):

MECCO has worked with several different commercial OPC servers as a conduit to retrieve custom marking information.

EtherNet/IP™ and PROFINET®: MECCO's EtherMark product supports these two industrial protocols for PLC to marker communication.

GETTING DATA FROM THE MARKER (POST-MARK)

In general, all of the techniques described above for getting information to the marker can be employed to obtain information from the marker. Information from the marker typically includes the date and time of marking, the data that was marked, barcode grading, and as-marked images, for example.

As standard operation, MECCO stores the marking information locally in the form of a Microsoft Excel compatible .CSV file, and to a Microsoft Access database file (.mdb). Any of the above described techniques can be used to export this data from the marker to the customer's information systems.



Complete laser marking workstations that are ready to mark, with streamlined designs and built-in functionality for easy, economical laser marking.

WATTAGE

20W 50W

Be ready for any challenge with the compact versatility of LightWriter™ by MECCO®. This line of fiber laser marking workstations are ready to mark right out of the box. They combine industrial-power laser technology with a convenient, well-designed safety enclosure. The result: easy and economical machines engineered to maximize your value, safety, and flexibility.

THE NEW GENERATION OF LASER MARKING INNOVATION

LIGHTWRITER 600 SERIES

- » 600mm Desktop Enclosure
- » Manual or Automatic Doors
- » 20W or 50W MOPA Fiber Laser
- » Up to 177mm² Marking Area

LIGHTWRITER 800 SERIES

- » 800mm Desktop Enclosure
- » Manual or Automatic Doors
- » 20W or 50W MOPA Fiber Laser
- » Up to 300mm² Marking Area

MARKING CAPABILITIES

Marks the widest variety of materials, including steel, titanium, aluminum, copper, ceramics, and some plastics.

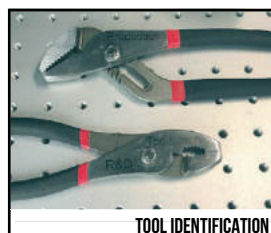

LIGHTWRITER 600 SERIES

AVAILABLE WITH MANUAL OR AUTOMATIC DOORS



Technology Partner
A ROCKWELL AUTOMATION PARTNER

LASER USE CONFIGURATIONS

Choose from a variety of configurations to meet laser safety standards.



CONTROL OPTIONS:

Select the level of automation and integration for your system.

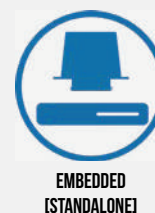
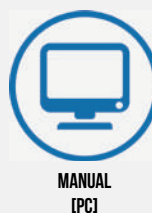

LIGHTWRITER™ BY MECCO® LASER SPECS

	LIGHTWRITER 620, A620	LIGHTWRITER 650, A650	LIGHTWRITER 820, A820	LIGHTWRITER 850, A850
System Dimensions (Manual Door)	584mm x 833mm x 927mm (22.99" x 32.80" x 36.50")		762mm x 1024mm x 927mm (30.00" x 40.31" x 36.50")	
System Dimensions (Automatic Door)	584mm x 833mm x 874mm (22.99"x32.80"x34.40")		762mm x 1024mm x 874mm (30.00" x 40.31" x 34.40")	
Standard Marking Field (160mm lens)	111mm x 111mm (4.37"x4.37")			
Max Part Size (160mm lens)	450mm x 330mm x 269mm (17.72" x 12.99" x 10.59")		625mm x 330mm x 269mm (24.61" x 12.99" x 10.59")	
Marking Field Upgrades: 254mm lens	177mm x 177mm mark area/ 155mm max part height (6.97" x 6.97" mark area/ 6.10" max part height)		177mm x 177mm mark area/ 305mm max part height (6.97" x 6.97" mark area/ 12.00" max part height)	
Marking Field Upgrades: 330mm lens	N/A		220mm x 220mm mark area/ 238mm max part height (8.66" x 8.66" mark area/ 9.37" max part height)	
Marking Field Upgrades: 420mm lens	N/A		300mm x 300mm mark area/ 114mm max part height (11.81" x 11.81" mark area/ 4.49" max part height)	
Laser Source	Ytterbium Fiber			
Output Power	20W	50W	20W	50W
Power Requirements	110/240 VAC 50/60 Hz, 5A			
Wavelength	1064nm			
Frequency Range (kHz)	1-588 kHz			
Pulse Duration (ns)	200 ns			
Operation Temperature Range	110/2232 - 97°F/0 -36°C 0 VAC, 50/60 Hz, 15A			
Cooling	Air			
Aiming Beam	Class II Red Diode (635 nm)			
PC	Required			
PC Connection	Ethernet			
Air Requirements (Automatic Door Only)	70 to 80 psi/5 Bar			
Software	WinLase Software			

3D models are available at www.mecco.com/support/resources

FEATURES

- » Sturdy industrial quality welded steel safety enclosure
- » Easy setup and operation
- » Class I enclosure is safe in virtually any environment
- » User-friendly WinLase by MECCO software
- » Low power consumption
- » 10" laser-safe viewing window
- » Work plate with ¼" tapped holes on 1" centers
- » Ethernet, monitor, and USB ports
- » Safety interlocks
- » Available in OEM model for integration



MODULAR DESIGN

The LightWriter's modular components allow for easy serviceability and maintenance.

LENS OPTIONS

Our high quality lenses are available in multiple configurations for this laser systems to meet the needs of your marking area.

Lens	Marking Field	Focal Length
160mm	111mm x 111mm (4.4" x 4.4")	182mm (7.17")
254mm	177mm x 177 (7.0" x 7.0")	299mm (11.77")
330mm	230mm x 230mm (9.1" x 9.1")	385mm (15.16")
420mm	336mm x 336mm (13.2" x 13.2")	491mm (19.33")

- Aluminum - Anodized
- Aluminum - Dark Mark 07
- Aluminum - Dark SS Wobble
- Aluminum - Deep Engrave C
- Aluminum - Frost Mark 04mr
- Aluminum - Light Mark 04mr
- Brass - Dark Mark 07mmB
- Brass - Dark SS Wobble
- SS - Deep Engrave

AUTOMATED FRONT LOADING DOOR OPTION

Optimize efficiency and ergonomics with an optional pneumatic door feature. Operators can load and unload parts with the touch of a button.



LASER MARKING RECIPE

Standard material settings are included with the laser marking profiles on our WYSIWYG system software.

SMARTMARK® FIBER LASER MARKING SYSTEM

The SMARTmark Fiber Laser is a versatile tool, combining a wide array of application capabilities with a user-friendly controller.

MODELS

20W 50W

Providing an industrial solution for product identification and traceability, SMARTmark Fiber Laser Marking Systems allow manufacturers to mark or engrave serial numbers, bar codes, 2D Data Matrix, and graphics on the widest variety of materials, including metals, plastics, and ceramics.

With two different power levels available, this laser can meet different application needs regarding depth, speed, and material, including cutting and welding.



MARKING CAPABILITIES

Marks the widest variety of materials, including steel, titanium, aluminum, copper, ceramics, and some plastics.



DARK WITH FROSTED BACKGROUND

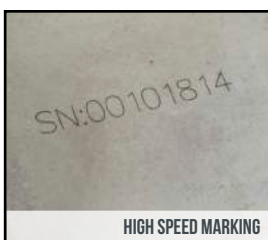

HIGH SPEED MARKING



CONTRAST ON BLACK PLASTIC



SURFACE MARK ON E-COATED STEEL



LASER USE CONFIGURATIONS

Choose from a variety of configurations to meet laser safety standards.

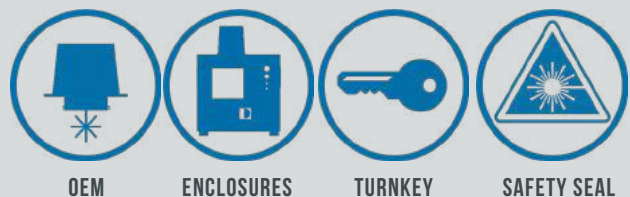

CONTROL OPTIONS

Select the level of automation and integration for your system.



SMARTMARK® FIBER LASER SPECS

Laser Source	Fiber, Ytterbium
Output Power	20W, 50W
Power Requirements	110/220 VAC, 10A, 50/60Hz
Wavelength	1064nm
Operation Mode	Pulsed
Pulse Rep Rate	20-500 kHz depending on model
Cooling	20W-50W: Air Cooled
Rail Weight	20 lbs
Rail Dimensions	20W-50W: L 19.74" x H 5.19" x W 4.96"
Cable Length	3 meters
Controller Dimensions	19.486" x 5.250" x 17.275"
Software	WinLase Software
Controls	LEC Embedded System Controller
Communications	Ethernet TCP/IP, EtherNet/IP™, PROFINET, Modbus TCP, RS232

3D models are available at www.mecco.com/support-resources.

20W & 50W LENS OPTIONS

Our high quality lenses are available in multiple configurations for this laser system to meet the needs of your marking area.

Lens	Marking Field	Focal Length
160mm	111mm x 111mm (4.4" x 4.4")	182mm (7.17")
254mm	177mm x 177 (7.0" x 7.0")	299mm (11.77")
330mm	230mm x 230mm (9.1" x 9.1")	385mm (15.16")
420mm	336mm x 336mm (13.2" x 13.2")	491mm (19.33")

SMARTMARK® VP MOPA FIBER LASER MARKER

Get higher contrast on plastics, faster deep engraving on metals, and clean black marks on clear anodized aluminum with the superior flexibility of variable pulse fiber MOPA technology.

MODELS

20W 100W 200W

Choose a fiber laser engraver that goes further with the SMARTmark® VP MOPA Fiber Laser Marking Machine from MECCO. The latest addition to the industry's largest line of industrial laser marking solutions, the VP MOPA Fiber Laser delivers the highest level of flexibility and control thanks to variable pulse MOPA technology.

With the ability to adjust the laser's pulse width, automotive, medical device, and other manufacturers will see results beyond what a traditional fiber laser marking machine can offer for a wide range of applications. The advantages include higher contrast on plastics, faster deep engraving marks on metal, and clean black marks on clear anodized aluminum.

MARKING CAPABILITIES

Marks the widest variety of materials, including steel, titanium, aluminum, copper, ceramics, and some plastics.



DAY/NIGHT MARKS FOR BACKLIT BUTTONS



CLEAN MARKS ON DELICATE SURFACES



CONTRAST ON BLACK PLASTIC



MARK CLEAR ANODIZED ALUMINUM



HUMAN AND MACHINE READABLE MARKS



DEEP MARKS ON AUTOMOTIVE STEEL



LASER USE CONFIGURATIONS

Choose from a variety of configurations to meet laser safety standards.

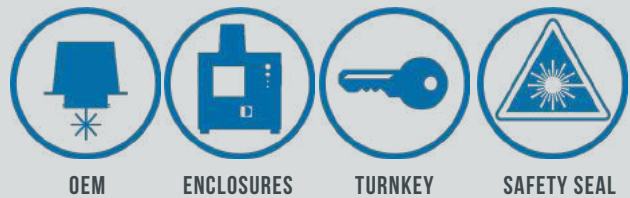

CONTROL OPTIONS

Select the level of automation and integration for your system.

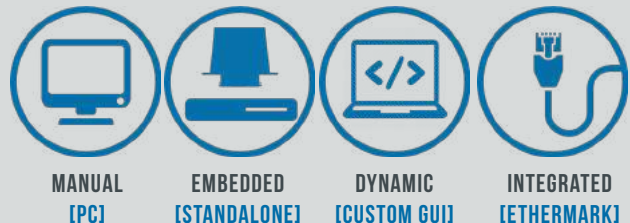

SMARTMARK® VP MOPA FIBER LASER SPECS

Laser Source	Fiber, Ytterbium, Variable Pulse Width
Output Power	20W, 100W, or 200W
Power Requirements	110/220VAC, 10/5A, 50/60Hz
Wavelength	1064nm
Operation Mode	Pulsed with Pulse Width Adjustment
Pulse Rep Rate	1-4000 kHz depending on model
Cooling	Air Cooled
Scanning Method	XY Galvanometer
Rail Weight	20W-100W: 20 lbs 200W: 27lbs
Rail Dimensions	20W-100W: L 19.74" x H 5.19" x W 4.96" 200W: L 23.2" x H 5.81" x W 5.16"
Cable Length	20W-100W: 9.8' 200W: 16.4'
Controller Dimensions	20W: L 19.49" x H 5.17" x W 18.99" 100W-200W: L 19.49" x H 11.9" x W 18.99"
Software	WinLase Software
Controls	LEC Embedded System Controller
Communications	Ethernet TCP/IP, EtherNet/IP™, PROFINET, Modbus TCP, RS232

3D models are available at www.mecco.com/support-resources.

20W LENS OPTIONS

Our high quality lenses are available in multiple configurations for this laser system to meet the needs of your marking area.

Lens	Marking Field	Focal Length
160mm	111mm x 111mm (4.4" x 4.4")	182mm (7.17")
254mm	177mm x 177 (7.0" x 7.0")	299mm (11.77")
330mm	230mm x 230mm (9.1" x 9.1")	385mm (15.16")
420mm	336mm x 336mm (13.2" x 13.2")	491mm (19.33")

100W & 200W LENS OPTIONS

Our high quality fused silica lenses are available in multiple configurations for this laser system to meet the needs of your marking area.

Lens	Marking Field	Focal Length
163mm	112mm x 112mm (4.4" x 4.4")	203.8mm (8.02")
254mm	160mm x 160mm (6.3" x 6.3")	304.7mm (12.0")
350mm	220mm x 220mm (8.6" x 8.6")	409.0mm (16.1")
450mm	320mm x 320mm (12.6" x 12.6")	516.0mm (20.31")

MECCOMARK® CO₂ LASER MARKING SYSTEM

Mark on wood, glass, rubber, plastics, cardboard, and product packaging with the only Rockwell Automation PartnerNetwork CO₂ Laser.

MODELS

10W 30W 100W

For product identification and traceability, the MECCOMark CO₂ Laser offers the most cost-effective solution in laser marking and engraving technology.

These compact units commonly replace other marking technologies such as ink jet, dot peen, and labeling due to the CO₂ laser's ability to achieve high-speed marking while maintaining mark quality. These lasers provide non-contrast marking in plastics as well as ink removal for date coding.

MARKING CAPABILITIES

If you need to mark organic materials, the CO₂ Laser is the best choice due to its larger wavelength that is easily absorbed by these materials.

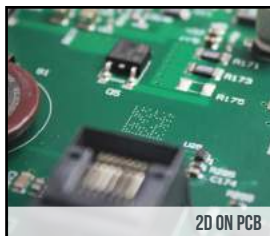

LASER USE CONFIGURATIONS

Choose from a variety of configurations to meet laser safety standards.

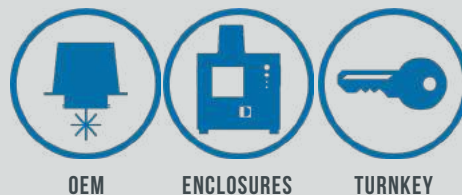

CONTROL OPTIONS

Select the level of automation and integration for your system.



MECCOMARK® CO₂ LASER SPECS

Laser Source	CO ₂
Output Power	10W, 30W, or 100W
Power Requirements	10W-30W: 110/220VAC, 10A, 50/60Hz 100W: 110/220VAC, 15A, 50/60Hz
Wavelength	10600nm
M²	1.2 ± 0.1
Operation Mode	Continuous Wave
Pulse Rep Rate	N/A
Cooling	10W-30W: Fan Assisted Air Cooling 100W: Water Cooled
Rail Weight	10W: 45 lbs 30W: 85 lbs 100W: 91 lbs
Rail Dimensions	10W: L 30.51" x H 7.06" x W 7.00" 30W: L 37.41" x H 11.21" x W 8.70" 100W: L 43.88" x H 9.61" x W 8.21"
Cable Length	9.8'
Controller Dimensions	L 18.99" x H 6.98" x W 17.95"
Software	WinLase Software
Controls	LEC Embedded System Controller
Communications	Ethernet TCP/IP, EtherNet/IP™, PROFINET, Modbus TCP, RS232

3D models are available at www.mecco.com/support-resources.

LENS OPTIONS

Our high quality lenses are available in multiple configurations for this laser system to meet the needs of your marking area.

Lens	Marking Field	Focal Length
100mm	70mm x 70mm (2.8" x 2.8")	81mm (3.19")
200mm	140mm x 140mm (5.5" x 5.5")	184mm (7.24")
360mm	250mm x 250mm (9.8" x 9.8")	351mm (13.82")
450mm	387mm x 387mm (15.2" x 15.2")	454mm (17.87")

SMARTMARK® GREEN LASER MARKING SYSTEM

MECCO's Green Laser creates readable marks at faster speeds without compromising the integrity of your part.

MODELS

20W

To achieve industrial product marking and traceability, MECCO's 20W SMARTmark® Green Laser marking machine creates highly readable, high-contrast permanent marks without distorting or altering your materials. Because it delivers a higher power output than similar "cold" lasers and has a wavelength of only 532nm, the result is faster marking with less heat. This makes it an ideal solution for thin metals and a wide variety of other heat-sensitive materials, including glass, film, and some plastics.

This powerful, versatile Green Laser marking machine can be utilized for multiple applications, from wafer marking to copper drilling or cutting. And as part of MECCO's line of SmartMark laser equipment, it integrates seamlessly with your existing equipment and assembly lines.

MARKING CAPABILITIES

These samples from SMARTmark® Green Lasers showcase some of the common applications that highlight its capabilities.



LASER USE CONFIGURATIONS

Choose from a variety of configurations to meet laser safety standards.



OEM

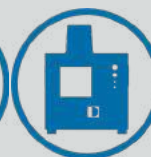

ENCLOSURES



TURNKEY

CONTROL OPTIONS

Select the level of automation and integration for your system.



MANUAL
[PC]



EMBEDDED
[STANDALONE]



DYNAMIC
[CUSTOM GUI]

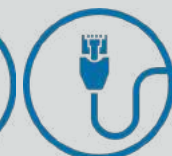

INTEGRATED
[ETHERMARK]

SMARTMARK® GREEN LASER SPECS

Laser Source	Pulsed Fiber Based Technology
Output Power	20W
Power Requirements	110VAC, 5A
Wavelength	532nm ± 10nm
Beam Quality (M²)	< 1.2
Operation Mode	Pulsed
Pulse Rep Rate	10-500kHz
Cooling	Controller and Optical Head are Air Cooled
Rail Weight	33 lbs
Rail Dimensions	L 20.63" x H 6.31" x W 6.00"
Cable Length	9.8'
Controller Weight	28 lbs
Controller Dimensions	L 19.49" x H 5.17" x W 18.99" + Source Dimensions
Software	WinLase Software
Controls	LEC Embedded System Controller
Communications	Ethernet TCP/IP, EtherNet/IP™, PROFINET, Modbus TCP, RS232

3D models are available at www.mecco.com/support-resources.

LENS OPTIONS

Our high quality lenses are available in multiple configurations for this laser system to meet the needs of your marking area.

Lens	Marking Field	Focal Length
160mm	122mm x 122mm (5.0" x 5.0")	178mm (7.00")
255mm	200mm x 200mm (8.1" x 8.1")	301mm (11.84")
330mm	263mm x 263mm (10.3" x 10.3")	386mm (15.18")
420mm	345mm x 345mm (13.5" x 13.5")	486mm (19.13")

SMARTMARK® UV LASER MARKING SYSTEM

Create readable marks on heat-sensitive products with less waste for superior compliance and traceability.

MODELS

3W

Get flawless results on certain plastics, glass, ceramic and a variety of other organic or heat-sensitive materials with the SMARTmark 3W UV Laser marking Machine. “Cold marking” technology minimizes the heat stress that leads to costly product damage thanks to a 355nm UV laser wavelength.

A wide range of industries benefit from versatile UV laser technology. It delivers smooth, hygienic marks required of medical device manufacturers. In industries like electronics and automotive, UV lasers allow companies to mark small, delicate components, including circuit boards and silicon wafers, with less waste.



MARKING CAPABILITIES

Below are some of the applications best suited for marking with the SMARTmark UV laser.



2D BARCODE ON PLASTIC



2D BARCODE ON BLACK NYLON



QR CODE ON WHITE PBT



TEXT ON POLYPROPYLENE

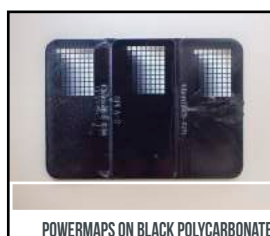

POWERMAPS ON BLACK POLYCARBONATE



TEXT ON GREEN PLASTIC



LASER USE CONFIGURATIONS

Choose from a variety of configurations to meet laser safety standards.

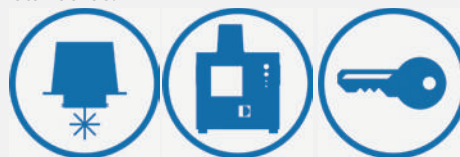

INTEGRATED

ENCLOSURES

TURNKEY

CONTROL OPTIONS

Select the level of automation and integration for your system.



MANUAL
[PC]

EMBEDDED
[STANDALONE]

DYNAMIC
[CUSTOM GUI]

INTEGRATED
[ETHERMARK]

SMARTMARK UV LASER SPECS

Laser Source	Pulsed Fiber Based Technology
Output Power	3W
Power Requirements	110VAC, SA
Wavelength	355nm ±10nm
Beam Quality (M2)	< 1.2
Operation Mode	Pulsed
Pulse Rep Rate	10-300kHz
Cooling	Controller and Optical Head are Air Cooled
Rail Weight	33 lbs
Rail Dimensions	L 20.58" x H 6.57" x W 6.38"
Cable Length	9.8'
Controller Weight	28 lbs
Controller Dimensions	L 19.49" x H 5.17" x W 18.99" + Source Dimensions
Source Dimensions	L 10.63" x H 3.48" x W 10.06"
Software	WinLase Software
Controls	LEC Embedded System Controller
Communications	Ethernet TCP/IP, EtherNet/IP, PROFINET, Modbus TCP, RS 232

3D models are available at www.mecco.com/support-resources

LENS OPTIONS

Our high quality lenses are available in multiple configurations for this laser system to meet the needs of your marking area.

Lens	Marking Field	Focal Length
170mm	112mm x 112mm (5.0" x 5.0")	239mm (9.41")
255mm	190mm x 190mm (8.0" x 8.0")	320mm (12.59")

SMARTMARK® MINI ENCLOSURE



SPECIFICATIONS

Dimensions	15.38" wide x 13.25" deep x 14.75" high
Weight	45 lbs
Z-Axis Movement	5"
Z-Axis Adjustment	Fixed or Programmable
Cooling	Air cooled
Power Requirements	110/220VAC, 50/60 Hz, 15A
Max Part Dimensions	9" wide x 8.3" deep
Door Opening	9" wide by 10" tall

LENS OPTIONS

160MM	Max. Part Height: 5"
--------------	----------------------

THE DESKTOP SOLUTION

The Mini Enclosure has been specifically designed as a desktop solution with a small footprint for the most compact Class I enclosure. Its features make this enclosure a value packed, low-cost solution for one-piece workflow or trays of small parts.

Access more drawings and the 3D model of this enclosure at www.mecco.com/support-resources.

FEATURES:

- COMPACT FOOTPRINT FOR DESKTOP OPERATION
- OPTION FOR INTERNAL SINGLE BOARD COMPUTER
- CLASS I LASER-SAFE
- LASER SAFE VIEWING WINDOW
- START MARK BUTTON
- SAFETY INTERLOCKS

DIMENSIONS

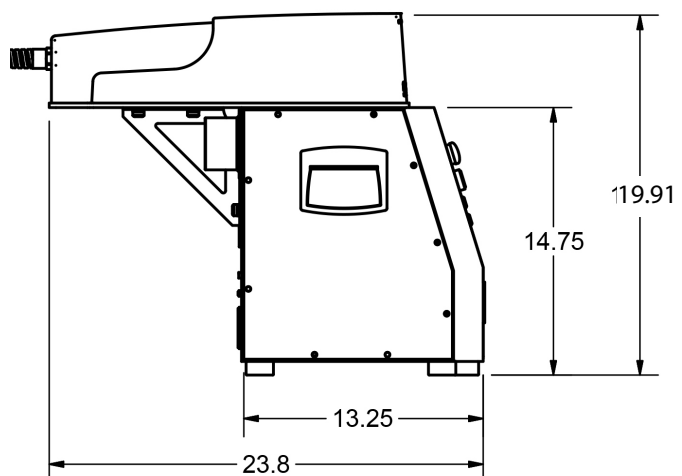
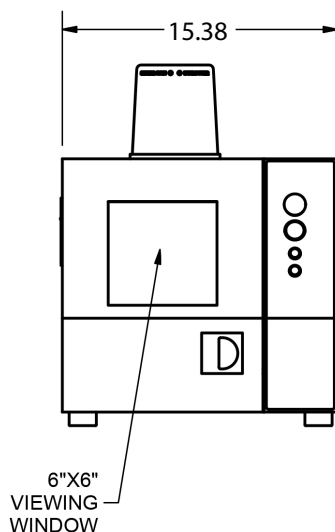

**General dimensions. Please consult factory for specific applications*

SMARTMARK® SMALL ENCLOSURE



TABLETOP SYSTEM FOR SMALL PARTS

The Small Enclosure is sized for tabletop use, featuring a vertically-opening door to save workspace. The simplicity of this system is a budget-conscious option that retains the quality and safety benefits of a high end system without compromising quality.

Access more drawings and the 3D model of this enclosure at www.mecco.com/support-resources

SPECIFICATIONS

Dimensions	23" wide x 30" deep x 37" high
Weight	350 lbs
Z-Axis Movement	Up to 10.5"
Z-Axis Adjustment	Fixed or Programmable
Cooling	Air Cooled
Power Requirements	110/220VAC, 50/60 Hz, 15A
Max Part Dimensions	20" wide x 15" deep
Door Opening	20" wide x 14" tall

LENS OPTIONS

160MM	Max. Part Height: 10"
254MM	Max. Part Height: 5"
330MM	Max. Part Height: 2.5"

FEATURES:

- HINGED MANUAL VERTICAL DOOR
- WORK PLATE WITH 1/4" TAPPED HOLES ON 1" CENTERS
- MAINTENANCE ACCESS PANELS
- LASER SAFE VIEWING WINDOW - 10" SQUARE
- EXHAUST TUBE PORT (3" DIAMETER)
- PORTS FOR ETHERNET, MONITOR, USB (3)
- SAFETY INTERLOCKS

DIMENSIONS

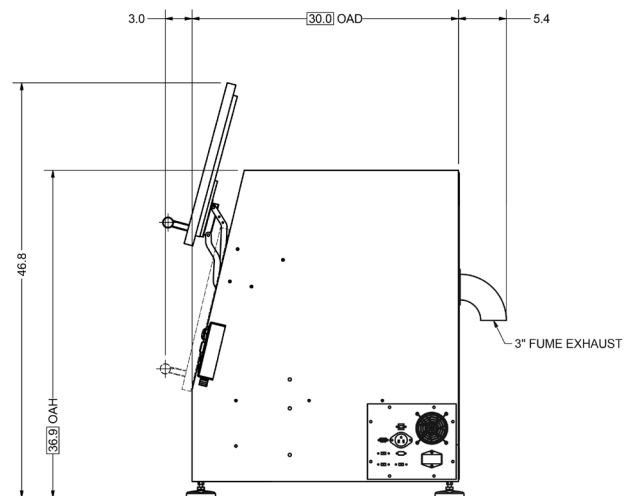
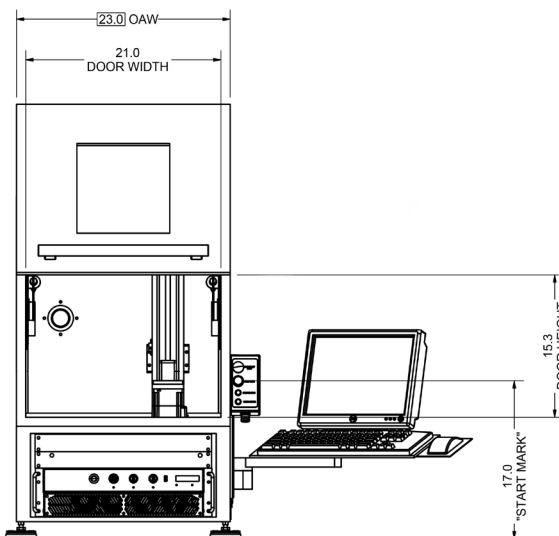

*General dimensions. Please consult factory for specific applications

SMARTMARK® LARGE ENCLOSURE

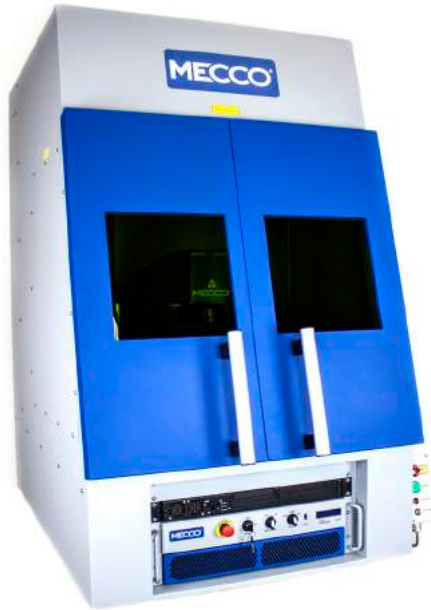

MARK LARGER PARTS OR BATCHES

The Large Enclosure is a Class I laser safety enclosure for your medium to large parts. It is also ideal for marking multiple parts at once. This system is easily customizable with removable side panels, side doors, and more.

Access more drawings and the 3D model of this enclosure at www.mecco.com/support-resources.

SPECIFICATIONS

Dimensions	30" wide x 42" deep x 56" high
Weight	500 lbs
Z-Axis Movement	26"
Z-Axis Adjustment	Fixed or Programmable
Cooling	Air cooled
Power Requirements	110/220VAC, 50/60 Hz, 15A
Max Part Dimensions	28" wide x 26" deep
Door Opening	26" wide x 23" tall

LENS OPTIONS

160MM	Max. Part Height: 26"
254MM	Max. Part Height: 21"
330MM	Max. Part Height: 18"
420MM	Max. Part Height: 13"

FEATURES:

- LASER SAFE VIEWING PANELS
- MANUAL SLIDE DOORS
- COMPLETE SAFETY INTERLOCK SYSTEM
- MAINTENANCE ACCESS PANELS
- START MARK BUTTON
- SWIVEL MOUNT FOR MONITOR & KEYBOARD

DIMENSIONS

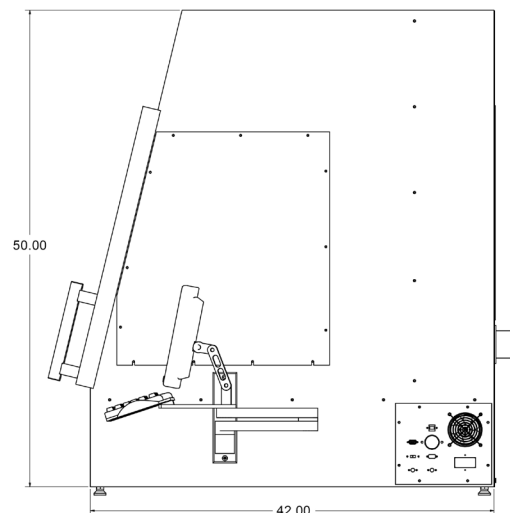
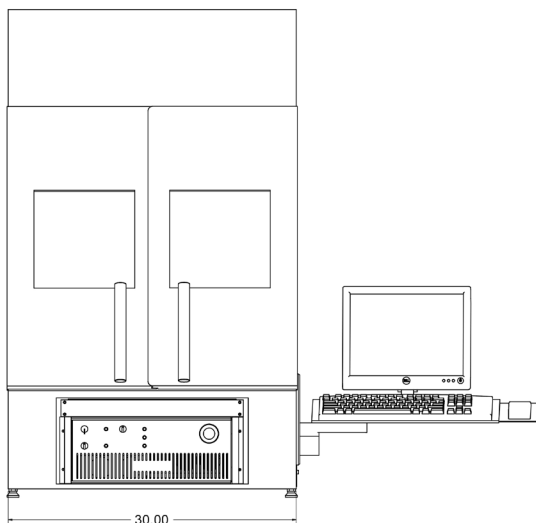

*General dimensions. Please consult factory for specific applications

SMARTMARK® ROTARY WORKSTATIONS



CONFIGURATIONS

Enclosure	Dial Table (Ø)	No. of Positions
Small	16"	2 or 4
Large	24"	2 or 4

**For maximum part sizes, please consult factory. Dimensions may vary slightly from standard enclosure models.*

IMPROVE PART HANDLING EFFICIENCY

Available in various configurations within the SMARTmark Small and Large Enclosures, the Rotary Workstation allows for other process steps to be conducted while laser marking occurs inside the enclosure. Configurations could be adjusted for faster throughput or automated vision verification steps pre- and post-laser marking.

Access more drawings and the 3D model of this enclosure at www.mecco.com/support-resources.

ROTARY INDEXER

Up to 8x Faster in a More Compact Design

Software-controlled rotation for marking around the circumference of parts. Motion is programmable through our laser marking software.

CAPACITY:

5" AVAILABLE PART DIAMETER
MAX PART WEIGHT OF 100 LBS

FEATURES:

- FIXTURE MOUNTING HOLES IN PLATE PER CUSTOMER-SUPPLIED FIXTURES
- LIGHT CURTAIN FOR OPERATOR SAFETY
- PROGRAMMABLE Z-AXIS WORK DECK WITH 11" VERTICAL TRAVEL
- MAINTENANCE ACCESS PANELS WITH SAFETY INTERLOCKS
- MINIMUM 23" X 42" X 39" OVERALL DIMENSIONS



INTEGRATED VISION FOR VERIFICATION

Leading Technology for Manufacturing Automation

Adding vision capabilities to your SMARTmark Laser is a vital part of traceability and quality control for your parts. It enables tracking, sorting, and identifying through part type, orientation and mark area recognition, mark grading, and defect detection.

With a great amount of flexibility in how the options can be customized per project, verification and data collection can be used to improve your processes by connecting with your database.

Using high quality 2D bar code marking and optical character recognition (OCR), you can ensure good quality and meet grading standards for your marks while identifying defective parts that can be discarded.



- » Program templates for Cognex Camera supplied by MECCO
- » Easy setup within EtherMark®
- » Various lighting options to optimize readability per material

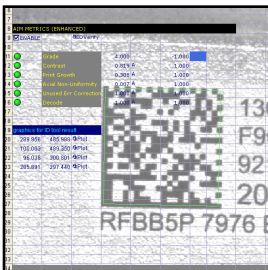

2D VERIFICATION & OCR

Ensure your mark meets specification every time with 2D verification and optical character recognition. What you do with marks that receive a low grade is up to you: you have the option to create settings that will automatically re-mark those low-graded marks.

- » Integrate fix mount or handheld scanners
- » Fix-mounted verification systems comply with ISO 15426-2
- » Verifies to the following symbol grading standards: ISO 15415, AS 9132, ISO 16022, AIM DPM Quality Guidelines 2006-1
- » Data Construction Validation includes GS1, UID MIL STD 130N, ISO 15418 and ISO 15434



FEATURE RECOGNITION

With a vision system, you can automate the process of identifying different parts. This allows you to mark different types and sizes of parts with one system, with no need for adjustment by an operator.

- » Range of lighting options tailored to the application
- » Automatic defect detection

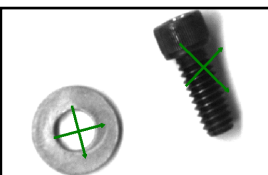

PART LOCATION & RECOGNITION

Automatically detect XY and rotational position, and apply marks in a specific location.

- » Eliminates fixturing costs for different parts
- » Save job files that remember part shape, eliminating the possibility of marking the wrong part

ENCLOSURE OPTIONS

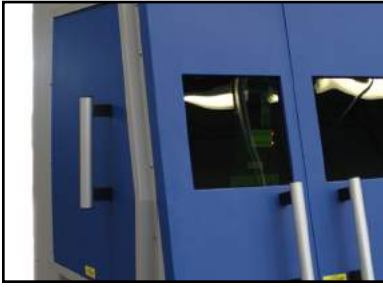

SIDE DOOR

Add a side door to an enclosure for easier loading and unloading of oversized parts. Side doors are also helpful in rotary workstations so that you can view the back of the rotary table.

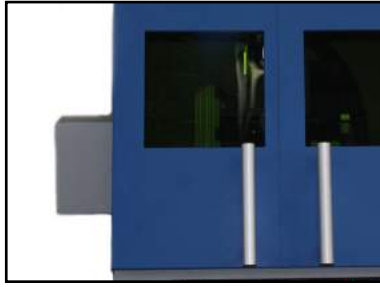

PASS THROUGH

Adding a pass through to your enclosure provides a way to mark parts on a conveyor or parts that are too long for the enclosure while still maintaining a small footprint on your production floor. Note: May change safety classification of enclosure.

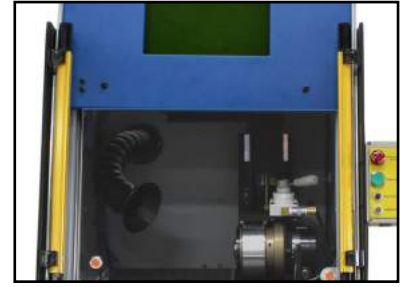

PNEUMATIC DOOR

Air-powered lifting mechanism of the door includes light curtain or bumper bars to prevent injuries. Configuration options:

- » Auto open upon marking completion
- » Foot pedal activation
- » Dual hand controls



FUME EXTRACTOR

Add a fume extractor to your enclosure system to remove gas and odor in the air during the laser marking process.

- » HEPA filter keeps air healthy
- » Protects the laser lens against debris
- » Turns on only when laser is in use
- » Requires separate 110VAC, 15A circuit

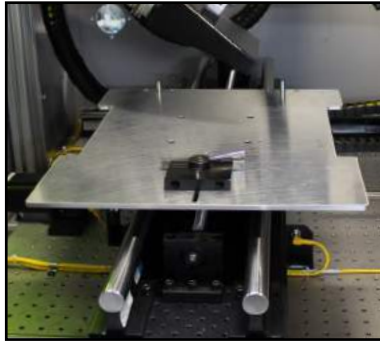

XY TABLES: 10X10 - 20X20

Reduce the frequency that operators have to load more parts by adding an XY table to increase marking area. This programmable moving surface allows you to maintain a small spot size for detail marking while marking a larger area.



NEMA ENCLOSURES

Add an air-tight, clean environment enclosure to your system and extend the life of your laser.

- » Protects electronics from heat and dirt
- » From NEMA 1 to NEMA 12
- » Vortex cooler uses compressed air
- » Programmable A/C unit with digital thermostat shuts laser down over 105°F

CHOOSE YOUR BASE

WORK TABLES

Extruded aluminum or welded steel tables can be constructed to any height for ergonomic use by the operator.

- » Adjustable feet stabilizers
- » Keeps enclosure secure
- » Optional castors for easy moving



SMARTMARK® SAFETY SEAL

The SMARTmark Safety Seal allows for Class I laser-safe integration without large enclosures.

MODELS

20W 50W 100W 200W

MECCO's patented Safety Seal technology uses the part being marked as the sixth side of the enclosure by vacuum sealing against it, creating a light-tight laser-safe environment.

The system is constantly drawing and measuring vacuum pressure on the part during the marking process. Sensors monitor the pressure, as well as part presence and cylinder position, in order to ensure that the Safety Seal meets all requirements for marking. If these safety conditions are not met or vacuum pressure drops while marking is in progress, the Safety Seal will close the safety shutter so that the laser output is interrupted. This safety circuit ensures laser safety at all times during the marking process.

MARKING CAPABILITIES

The Safety Seal is compatible with SMARTmark Fiber and Tiburon Lasers, so you can mark on virtually all metals and plastics.



20 - 100W MODEL

200W MODEL



SAFETY SEAL CONTROLLERS

The Safety Seal comes with an additional control box for its specific features:



- » Power
- » Cylinder Movement
- » Vacuum Power
- » Shutter State
- » Part Presence

CONTROL OPTIONS

Select the level of automation and integration for your system.



MANUAL
[PC]

EMBEDDED
[STANDALONE]

DYNAMIC
[CUSTOM GUI]

SMARTMARK® SAFETY SEAL SPECS

Laser Compatibility	Fiber, VP MOPA Fiber
Output Power	20W, 50W, 100W, or 200W
Power Requirements	20W-100W: 110/220 VAC, 10/5A, 50/60Hz 200W: 110/220 VAC, 15/8A, 50/60Hz
Marking Window Size	Up to 3.5" x 3.5"*
Wavelength	1064nm
M²	<1.4
Operation Mode	Pulsed
Pulse Rep Rate	Fiber: 25-200 kHz depending on model VP MOPA Fiber: 25-600 kHz depending on model
Cooling	Air Cooled
Scanning Method	XY galvanometer
Weight	20W-100W: 47 lbs + Laser Rail (20 lbs) 200W: 47 lbs + Laser Rail (27 lbs)
Dimensions	18" x 19.25" x 10.5" + Laser Rail
Cable Length	9'*
Controller Dimensions	19.5" x 5.2" x 18" + Laser Controller
Max Line Speed	3,000 mm/sec using 254mm lens
Software	WinLase Software
Controls	LEC Embedded System Controller
Communications	Discrete I/O

*Contact MECCO if you need a customized solution beyond our standard product offering.

SENSORS

Using sensors to verify that safety conditions are met, the Safety Seal ensures that the laser only fires when properly connected.



CONTACT SEAL

The contact seal is engineered to your part geometry to ensure a Class I environment, allowing the Safety Seal to seal on different shapes, materials, and casts.



PROTECTIVE LENS ASSEMBLY

This interlocked safety lens keeps the main system's optics clean and can be removed for easy maintenance.



OUR LIFETIME SERVICE GUARANTEE APPLICATION ENGINEERING

Discover the MECCO Difference

Your success in marking and traceability depends on more than technology alone. You need a team you can rely on — both now and long after your systems are in place.

That's why MECCO offers access to our state-of-the-art applications lab for the life of your product. This valuable, complimentary benefit allows you to save time and money with expert service and support that is one click or call away.

You receive:

- » Free sample marking prior to purchase
- » Sample mark job file post-purchase
- » Application support for new products
- » Help with job files
- » Troubleshooting for new materials



“Having a lifetime use of the MECCO laser lab to troubleshoot and assist in new markings is an extremely valuable offering which made the difference when considering laser systems.”

- **MARK ROTTINGER**
Manufacturing Engineer

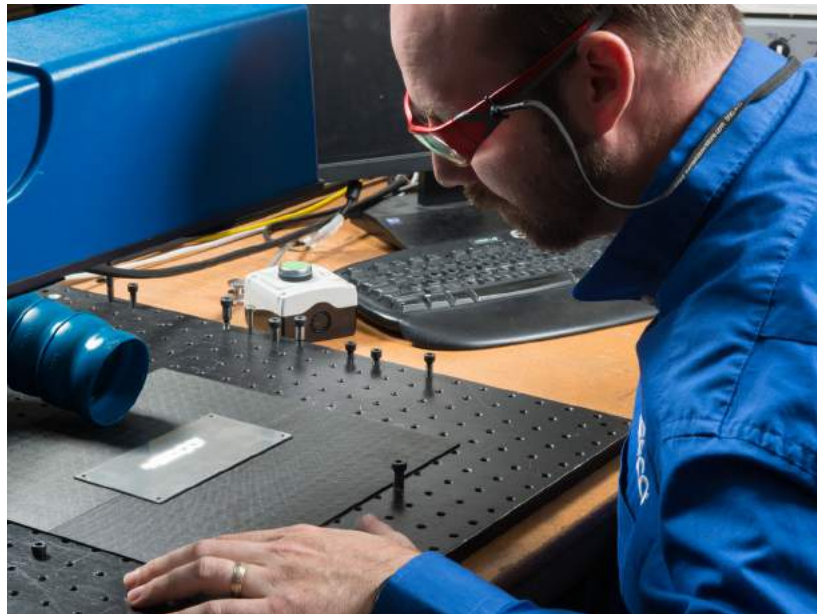

RECEIVE FREE MARKING SAMPLES

At MECCO, we know the importance of understanding how equipment will mark your specific parts. More importantly, we know that there are often unknown variables preventing you from getting the best possible mark.

Our consultative approach to applications engineering means that we work through your project challenges together to ensure your particular goals are met and that you are 100% satisfied.

OUR PROCESS:

- » **Request:** Send us a request at mecco.com/sample-marking
- » **Receipt:** Our service team calls to arrange shipment.
- » **Shipment:** You ship your sample parts to our applications team.
- » **Review:** An applications engineer calls to review your needs.
- » **Processing:** We mark your samples within an agreed turnaround.
- » **Prelim feedback:** We email photos of marked parts for your review.
- » **Report:** We adjust to your feedback and send a full sample report.
- » **Return:** The marked parts are shipped back to you.
- » **Debrief:** We arrange a debrief session to review sample quality.

LASER MARKING TURNKEY SOLUTIONS

Because One Size Doesn't Fit All

Traceability doesn't operate in a vacuum. With the Industrial Internet of Things (IoT) and connected factories becoming more widespread, there's more to part marking than ordering a basic laser. That's why MECCO builds complete solutions for **your industry, your material, and your requirements.**

We are the leader in manufacturing sophisticated, custom configured workstations and retrofitting SMARTmark lasers into existing integrations. You can expect to work with real people who are really good at what they do, striving to make your life easier by providing you technical expertise and a system designed to work for you.



AUTOMATE PART LOADING
WITH ROBOTICS OR CONVEYORS & CUSTOM FIXTURES



INCREASE ACCURACY OF DATA ENTRY
SCANNERS, HMI SCREENS OR DATABASE INTEGRATION



INCREASE QUALITY
WITH INTEGRATED VISION



ENSURE SAFETY
WITH LIGHT CURTAINS AND HAND CONTROLS

THE MECCO® EXPERIENCE

OUR PROCESS

Our goal is simple: to provide not only the best products but to deliver an exceptional customer experience with a team of certified experts who revolve around your needs.

As a result, you can expect successful marking solutions that align with your evolving business goals—we guarantee it. Below is the process we at MECCO use to help our clients find the ideal marking solution for their needs.

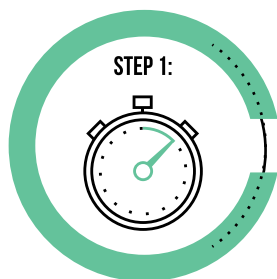

STEP 1: DEFINE YOUR REQUIREMENTS

We don't rush to offer you a piece of marking equipment – whether you work with our Inside Sales Engineers and Field Specialists or a MECCO-certified partner, we begin the process by taking the time to understand your needs, your budget, your bottom-line goals and ensure we deliver the perfect solution for your business.

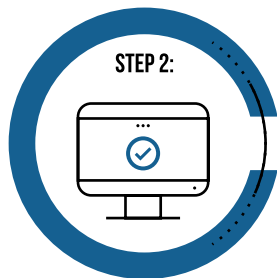

STEP 2: ASSESS TECHNICAL FEASIBILITY

To ensure you get the best mark every time, we put your materials to the test with product demos or sample testing by Applications Engineers at our state-of-the-art lab.

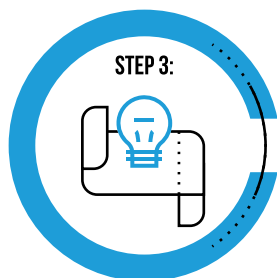

STEP 3: DELIVER YOUR SOLUTION

Our experienced team will recommend a solution from our extensive line of MECCO-engineered laser and pin marking products. If we don't have it, we can build a custom solution built to your exact specifications.

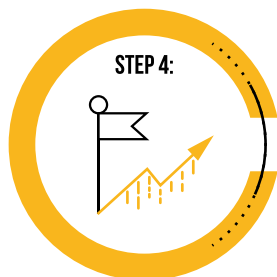

STEP 4: PROVIDE LIFETIME SERVICE

After installation, your MECCO Experience continues with timely service and support – including free sample marking and regular Account Reviews – so you can rest assured you'll have an optimized marking system and minimal downtime.



SERVICE & SUPPORT

INSTALLATION & TRAINING

MECCO performs installation and on-site training of machine operations, preventive maintenance, and system troubleshooting. Continuing education is also available via webinars.

TROUBLESHOOTING

Get help fast with a variety of troubleshooting options. MECCO offers remote diagnostics, lifetime phone support, and a service team that brings technical expertise right to your facility: no shipping or uninstallation required.

PARTS

Standard components, including scan heads, control boards, and electronics are stocked for overnight shipment. For complex issues, MECCO offers no-cost loaner components and systems during the repair process.

PREVENTATIVE MAINTENANCE

Structured to ensure that your equipment is functioning at the highest possible degree of efficiency, this plan delivers extended equipment life to control replacement costs. The yearly plan includes a 28-point checklist, review of the job settings, and unlimited software updates.

VIRTUAL PRODUCT SUPPORT

Get 24/7 online training and troubleshooting support via Virtual Product Support: a library of engineering, training, and support resources, including videos and documentation for basic troubleshooting and repairs.

www.mecco.com/support

MECCO®

290 Executive Drive, Suite 200 • Cranberry Twp, PA 16066
Phone: 724-779-9555 • Fax: 724-779-9556

1-888-369-9190 | info@mecco.com | www.mecco.com

CT0318-A