

TAPERED THREAD INSPECTION - ROTARY DRILL STEMS

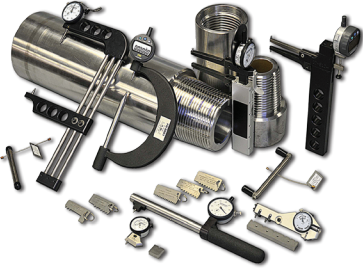

GAGEMAKER DETERCO, INC.

Required Equipment

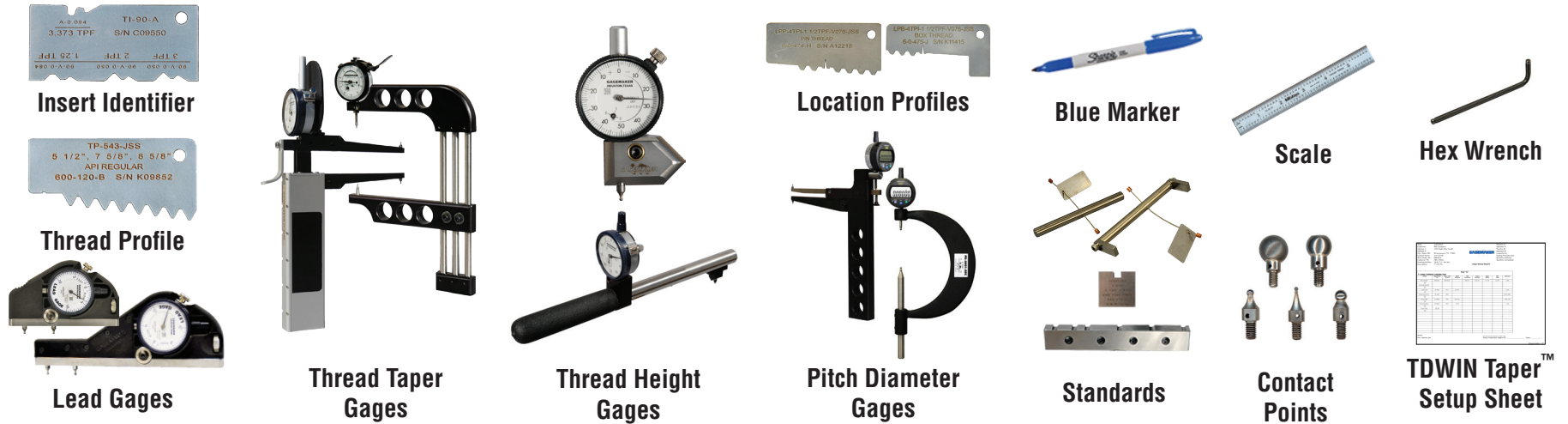

Inspection Process

Step 1: Insert Identification

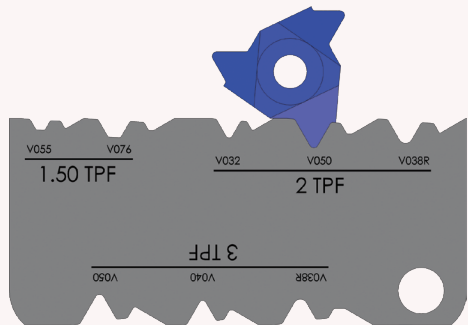

Step 2: Thread Form

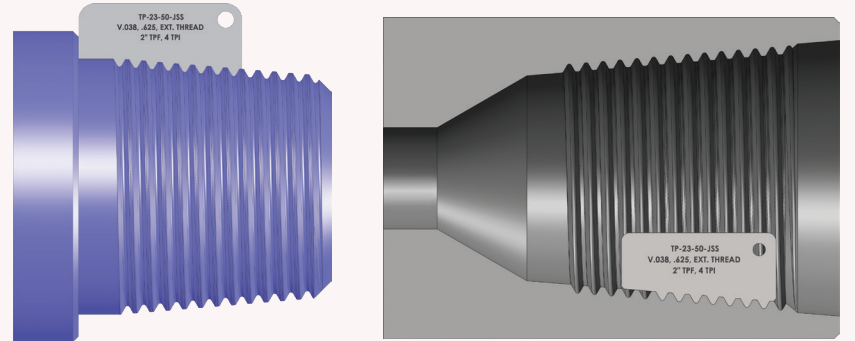

Step 3: Pitch Diameter Location

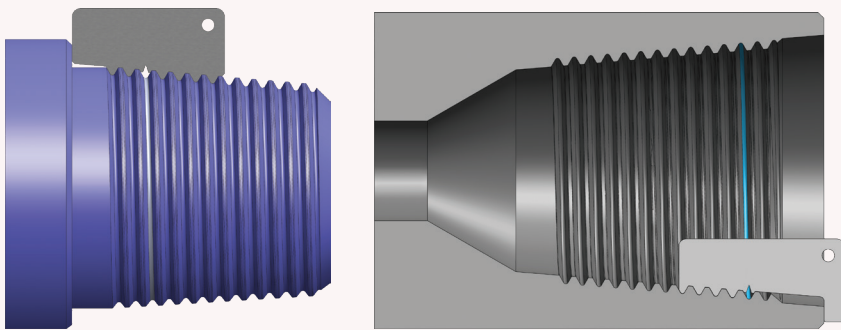

Step 4: Pitch Diameter

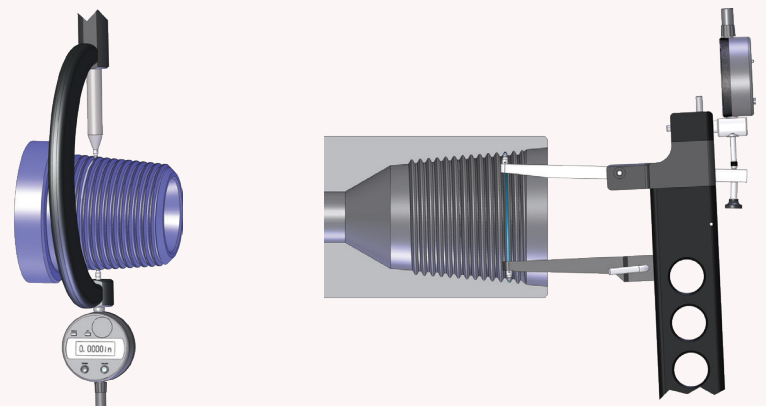

Step 5: Thread Lead

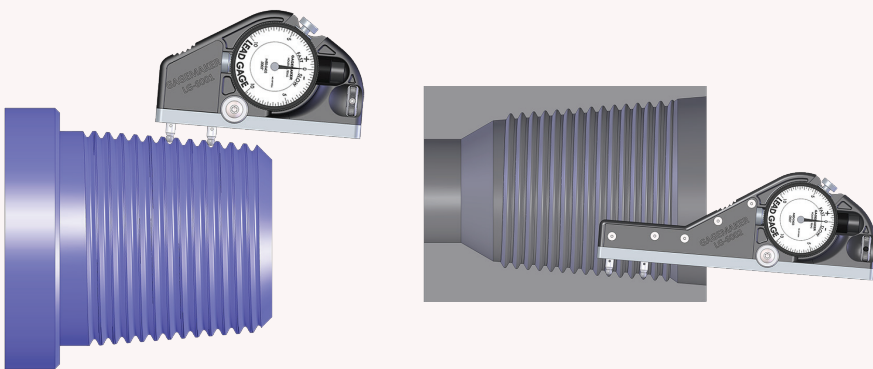

Step 6: Thread Taper

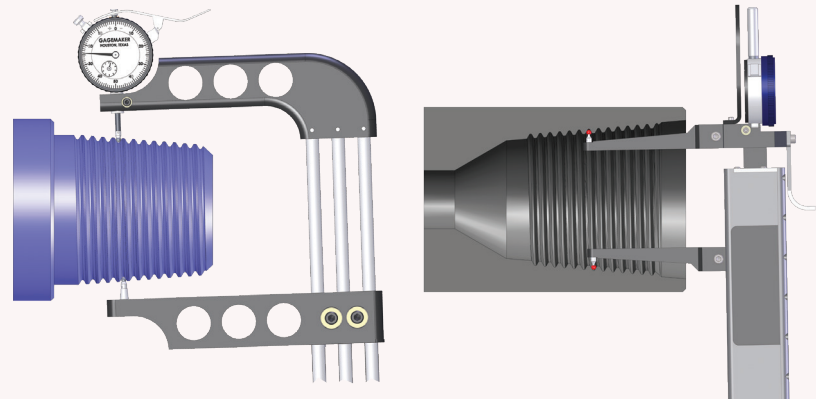

Step 7: Thread Height

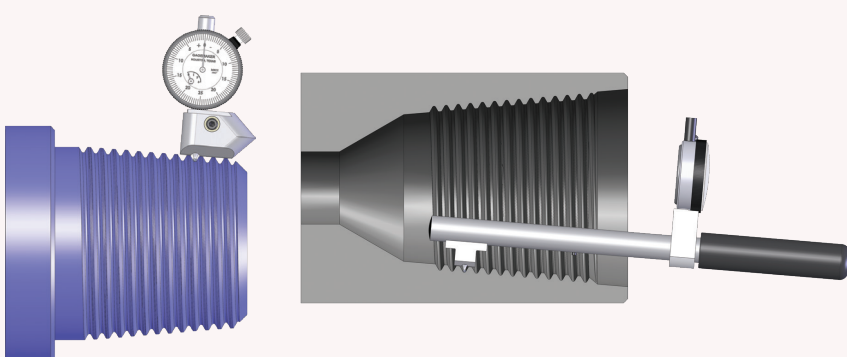

Step 8: Thread Length

